

No.7 Fall, 1987

# THIRD IMPERIUM

THE CANADIAN TRAVELLER MAGAZINE



MIKE JACKSON '87

# SORAG

THE ORIGINAL IS BACK!



**And this time, it's no secret...**

The Scientific Operations Research and Administration Group, or SORAG, is an intelligence and counter-intelligence service. Its purpose is to infiltrate and perform surveillance on various interstellar governments and military services. Activities within the sphere of SORAG's mission include: guerilla warfare, subversion, sabotage, escape and evasion, "black" and "gray" psychological operations, and other operations best described as unconventional warfare....

Rediscover the mysteries and secrets of the Zhodani Consulate's premier intelligence organization. Learn how the tactful Zhodani have managed to undermine important governments across the Imperial rim and assume control of areas which many have once thought to be uncontrollable. Unearth ways in which insipid worlds can become hideaways for agents and operatives. Learn it all.

This book contains tools of the trade, vehicles, pharmaceuticals, and even a character generation system for agents. New skills, new weapons, and the best surveillance devices ever created are also to be found here. A background of this formidable organization and an explanation of SORAG's purposes are also included.

In 1981, the Paranoia Press took a very bold step by releasing SORAG. This material gave Traveller® its very first glimpse of espionage and laid forth a whole new universe of adventure and excitement for players and referees alike. Since the appearance of SORAG, nothing has even come close to comparing with the brilliant organization and utility it holds - NOTHING!

And now it's back! The original book, complete, unrevised and unedited, is available through the SORAG Laboratories and in some hobby shops where Traveller products are sold. From its very first day of sale, SORAG was bound to be a classic. So don't you be the one who missed out - "Come Visit Our Universe...."

To order your copy of the SORAG Handbook of Organization and Equipment, send a check or money order for \$4 to:

The SORAG Laboratories  
4200 Park Place 217,  
Tyler, Texas 75703 USA

Make all checks and money orders out to GREGG M. GILES. All funds must be in US Dollars. Send no cash. Addresses not in Canada, APO, or FPO must add 50¢ US.

# NOTES FROM THE CAPITAL

Welcome to another adventure-packed issue of *Third Imperium*! We have a lot of special articles this issue, including customized starships, the HoloSuit (designed by Duncan Torrance) and our first *MegaTraveller* article, "Personalities of the Rebellion."

But first, a brief errata: Last issue, our article on the planet Accrid listed the hydrographic percentage as 87% in the statistics and 7% in the article. 87% was an unfortunate typographical error; the latter value is correct.

Last issue's Notes from the Capital discussed the problem of contradicted Traveller articles. Well, not all of our articles have suffered. The Hive stunner in issue #3 fits in very nicely with Grand Census as a Neural Gun -- when firing it roll 2D (1-2: disorientation, 3-9: unconsciousness, 10-11: mind assault, 12: death).

Our articles on Cyborgs fit in as well, with the following notes:

- 1) Part 1 lists true clones as being TL 13. This is incorrect,

with the proper values listed in Part 3.

- 2) Grand Census lists various cybernetic replacements several tech levels before we do. The lower tech versions are primitive, clumsy, and undependable, whereas the T.I. article lists the tech levels at which they become practical and look and work like the original.
- 3) The TL of increased values (extra strength, extra running speed, etc.) should be raised to TL 12.
- 4) Part 2 mentions TL 15 cyborgs as being indistinguishable from normal humans. This is the same as Grand Census' 'Pseudobiological prosthetics.'

Finally, production of *I.N.S. Hammer* (advertised last issue) has been suspended until the release of all of *MegaTraveller*, in order to take advantage of any new rules. It should be on sale in November or December.

-Mike Jackson,  
Editor

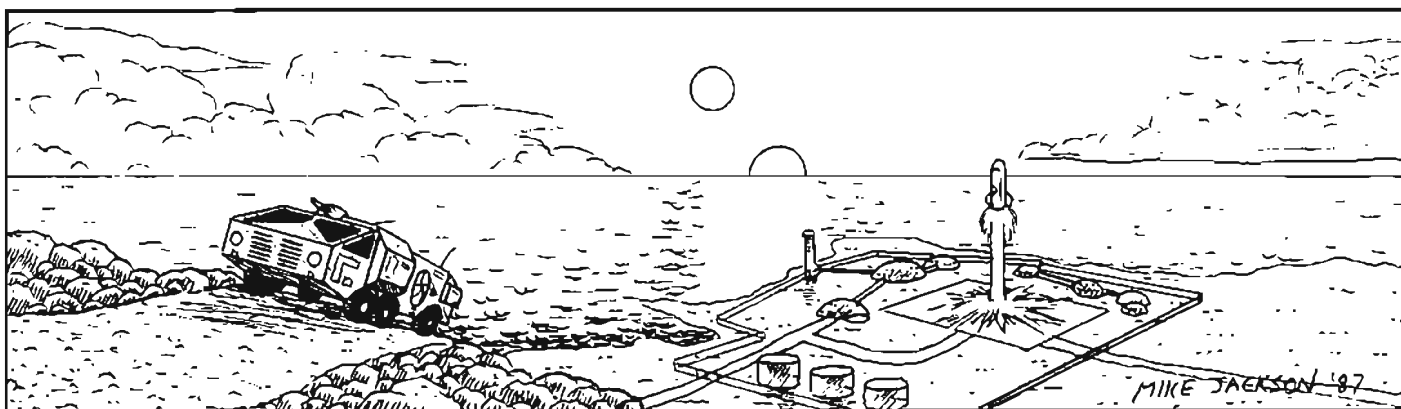

Personalities of the Rebellion.....	3
Hiver Embassy Ship.....	5
Dpres Subsector.....	7
Feature Adventure: The Gabriel Project.....	10
Imperial Navy Uniforms.....	15
Traveller's Hardware.....	16
Customized Starships.....	17
Traveller's Advice.....	19
Inside Equipment.....	19

STAFF: Mike Jackson, David New. Contributors: Duncan Torrance, Ed Edwards. Dedicated to Cameron Carrol.

Portions of this magazine are taken from materials published by GDW and Digest Group Publications, and are copyright 1987 by the respective groups. Data forms are used with the permission of GDW. TRAVELLER is a registered trademark of GDW.

*Third Imperium* is published quarterly by Mike Jackson. Send submissions, letters, and ads to No. 512, 4676 Yew St., Vancouver, BC, V6L 2J6. Rates: \$2.50 single copy, \$9.00 1 year subscription (Canada), \$2.00 single copy, \$7.50 1 year subscription (U.S.)

# PERSONALITIES of the REBELLION

The Rebellion of 1116 is the most chaotic period yet in Imperial history. Almost simultaneously, many new figures appear on the political scene, taking control of various parts of what was once Imperial space. This article contains information on the most important of these individuals.

## Dulinor, Archduke of Ilelish *the Usurper*

Noble 887CBF Age 50 CrUnlimited  
Administration-4 Leader-4 Handgun-4  
Bribery-1 Carousing-1 Jack-of-all-  
Trades-1

Archduke Dulinor is the principal player behind the assassination of the Emperor. He and his advisors concocted the plot; his personal troops killed Emperor Strepthon; and it was he who then claimed the throne.



After fleeing Capital in his cruiser, Dulinor returned to Ilelish to command his portion of the Imperial Navy. He now fights a military campaign to enforce his claim as Emperor of the Third Imperium.

Dulinor is a quiet, intelligent man who uses every moment of silence to plot new courses of action. He is highly charismatic, and regarded as an upstart by the Imperial nobility. Well known for his love of handguns, he does have a terrible temper when angered sufficiently, and often becomes incoherent with rage.

It is not clear why Dulinor chose to assassinate the Emperor, but it seems most likely that his motives were purely for personal gain.

As of 1116, Dulinor controls a fleet of some 2500 ships.

## "Emperor" Lucan *the Pretender*

Noble A867AF Age 27 CrUnlimited  
Carousing-1 Hunting-1

Lucan, younger brother of Prince Varian and nephew of Strepthon, is the most probable heir to the Iridium Throne. However, his private coronation ceremonies (up to now something totally unheard of) and rumours that it was he who killed his brother, the original heir, cast doubt upon his legitimacy as ruler, earning him the title of the "Pretender."



So far, Lucan has proven himself to be a poor ruler; this is most evidenced by his abuse of the Moot. Though rather charismatic in person, Lucan lacks the aura of strength and prestige which is necessary to rally the people about him.

Lucan is not particularly intelligent, and spent most of his time before the Rebellion participating in various sports. However, he still insists upon making all important decisions, heedless of his counselors' advice.

Lucan controls the majority of the Imperial fleet, with more than 6500 ships in his power at the start of the Rebellion.

## Norris, Archduke of Deneb

Navy 7B9CBF Age 42 CrLots  
Administration-2 Fleet Tactics-2  
Leader-2 Pilot-1 Zero-6 Weapons-1

Grand Admiral of the Marches, Duke of Regina, and Archduke of Deneb, Norris saved the Spinward Marches from the Zhodani during the Fifth Frontier War. When the frontier was cut off by Vargr invaders, he returned to the helm.



His main focus is currently on the Vargr frontier as he attempts to punch through to the rest of the Imperium. The Trojan Fleet is at work fighting a holding action against the invading Aslan.

Norris is calm, intelligent, and charming, as well as capable of rallying followers with ease. His command has saved the territories 'behind the claw' against extraordinary odds.

Norris has under his control some 2600 ships in 1116, but has fewer casualties than any other faction.

#### Lithinin, Archduke of Daibei

Noble 6578BF Age 62 CrLots  
Liaison-2 Jack-of-all-Trades-1 Grav  
Vehicles-1 Bribery-1 Computer-1

When Emperor Strephon was assassinated and Dulinor's fleet started to attack the Imperial forces, Lucan began calling the Daibei fleets to the Core. As Solomani forces commenced their advance on the sector, Lithinin declared independence in order to retain his forces.



For now, the Solomani Confederation is concentrating on the Imperium, but this situation will probably not last for long. Lithinin is a relatively slow, conservative man, but he has followed his counsel's advice in his strategies, so that Daibei and Reaver's Deep have become quite stable compared to other areas of human space.

Lithinin commands some 1800 ships at the start of the Rebellion.

#### Garin Kaarishuu, Regent of Antares

Navy 7989AE Age 31 CrLots  
Pilot-2 Navigation-1 Pistol-1  
Fleet Tactics-1

As the Rebellion continued, it became evident that Antares could expect no help from the Imperium to combat the invading Vargr. Kaarishuu decided to secede from the Imperium in 1117 and join the Julian Protectorate, a large confederation of human worlds which had bonded together expressly for defence against the Vargr raiders.



Kaarishuu is now a member of the Julian Council, the governing body of the Protectorate. She takes no predi-

cament very seriously, and often leaves her work to be done by others, regardless of their qualifications.

In 1116, Antares controls almost 1000 ships. After it joins with the Julian Protectorate, the combined fleets total about 3200.

#### Other Groups

The new Vilani Empire is controlled by the heads of Makhidkarun, Naasirka, and Sharurshid. They have decided upon Duke Sulmii as the new Shadow Emperor, but he holds no real power. The Vilani have scraped together about 1600 ships.

Vega and the remaining Imperial forces in the Solomani Rim banded together to defend against the Solomani. The current government consists of a council of 50 naval officers and planetary leaders, and a dozen Vegans. The combined fleet consists of over 1000 ships.

In 1117, the "other" Strephon appeared in Gushmege, claiming it was his double who was assassinated. He is physically identical to the Emperor, and has rallied some 400 ships to his cause. Doubters suspect that he is actually the result of a secret cloning experiment.

13 other small pockets, under various rulers, are scattered across the Imperium, all with forces numbering between 50 and 200 ships.

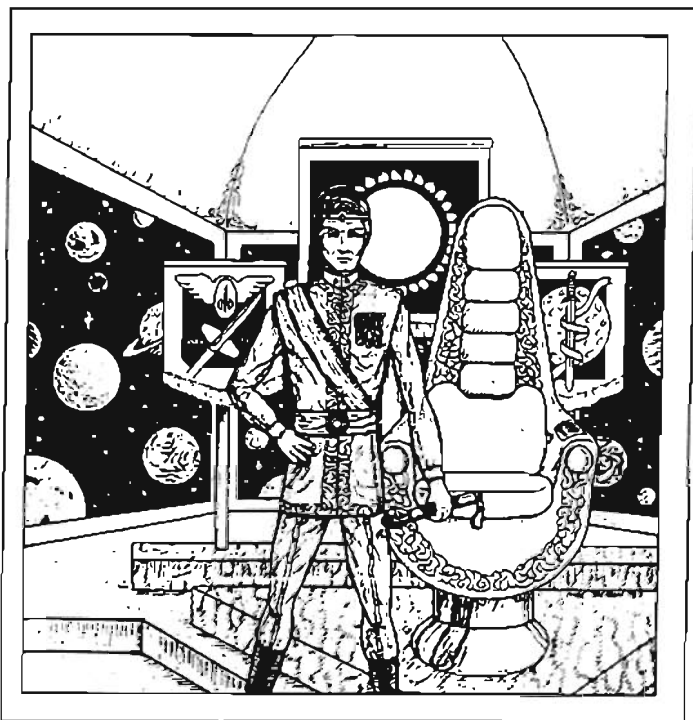

R.I.P.

# HIVER EMBASSEY SHIP

The Hiver Embassy Ship is a large transport vessel intended to carry Hiver Ambassadors between worlds. Its 50 staterooms and large cargo bay make it especially suited to this role. It is the most commonly encountered Hiver starship outside the Federation (although in such situations, two turrets are normally installed.)

The Hiver Embassy Ship has several special features. Like all Hiver ships, the decks are numbered from bottom to top (rather than from top to bottom, as in most human ships). It has a fumigation system to dispose of unwanted larvae, and it has 6 cleaning robots (filling a role similar to Snohls). The ship's computer has twice the capacity of normal, non-Hiver, model/2's.

## STATISTICS

Tonnage: 800 tons. 11 200m<sup>3</sup>.  
 Crew: 12.  
 Dimensions: 73.5L x 18w x 16h.  
 Acceleration: 1-G constant.  
 Jump: 2.  
 Power Plant: 2. 16 EP. Agility -2.  
 Engineering: 1 star patterns type Q14 dual fusion power plant driving a TR9795-83 jump drive and two Starmass Mark IV manoeuvre drives.  
 Gravitics: Standard inertial compensators. .7 G floor field.  
 Electronics: Star patterns Model/2 computer.  
 Armament: Two hardpoints. No turrets or weapons initially installed.  
 Screens: None.  
 Configuration: Close structure. Unstreamlined.  
 Capacity: 48 passengers. 184 tons cargo.  
 Vehicles: One 95-ton shuttle (40 tons cargo, 60 passengers, computer model/2).

## DECK PLAN LOCATIONS

1. Bridge (lower level). Navigator's station. Iris valve up to computer room.

2. Avionics.
3. Ship's Locker.
4. Airlock.
5. Library.
6. Sick Bay.
7. Robot Repair/Storage.
8. Robot Parts.
9. Reception/Lounge.
10. Fuel Scoops.
11. Fuel Tanks.
12. Manoeuvre Drive.
13. Shuttle Bridge.
14. Shuttle Airlock.
15. Passenger Compartment.
16. Shuttle Cargo Bay.
17. Cargo Lift. Rises to deck 2 cargo bay.
18. Shuttle Fuel.
19. Shuttle Drives.
20. Cargo Bay.
21. Cargo Lift. Lowers into shuttle cargo bay.
22. Upper Bridge. Pilot's station.
23. Computer. Iris valve down to lower bridge, up to lounge.
24. Storage.
- 25.-31. Staterooms.
32. Lounge/Common Area. Iris valve down to computer room.
33. Galley.
- 34.-50. Staterooms.
51. Jump Drive.
52. Power Plant.
53. Storage.
- 54.-78. Staterooms.
79. Galley.
80. Common Area.
- 81.-91. Staterooms.
92. Hardpoints.

Hiver Embassy Ship HN-8421222-000000-00000-0 MC+311.7 800 tons. Passengers=48 Low=0 Cargo=184 Fuel=180 EP=16 Agility=2 TL=10





### Deck Plan Symbols

	Interior Wall
	Sliding Door
	Bulkhead
	Maintenance Hatch
	Lift Shaft
<b>IRIS VALVE      MANUAL HATCH</b>	
	Iris Valve
	Manual Hatch
	Overhead
	Floor
	Both Floor and Overhead

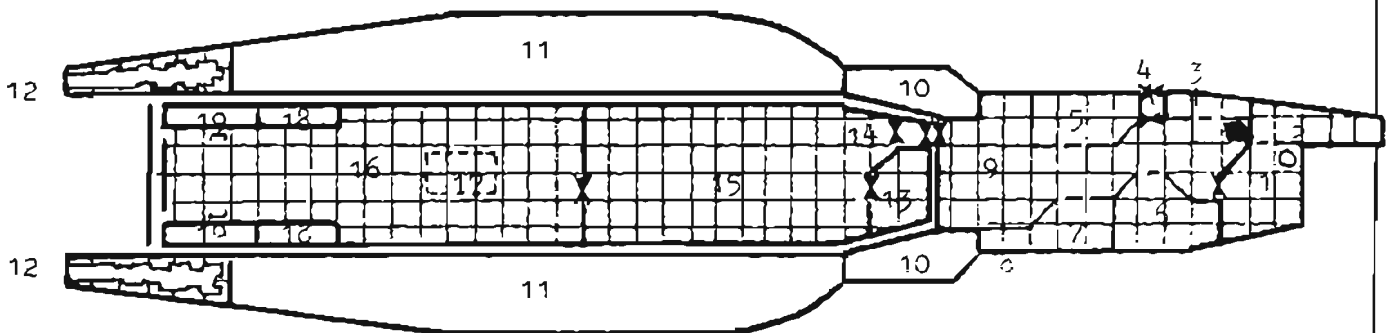
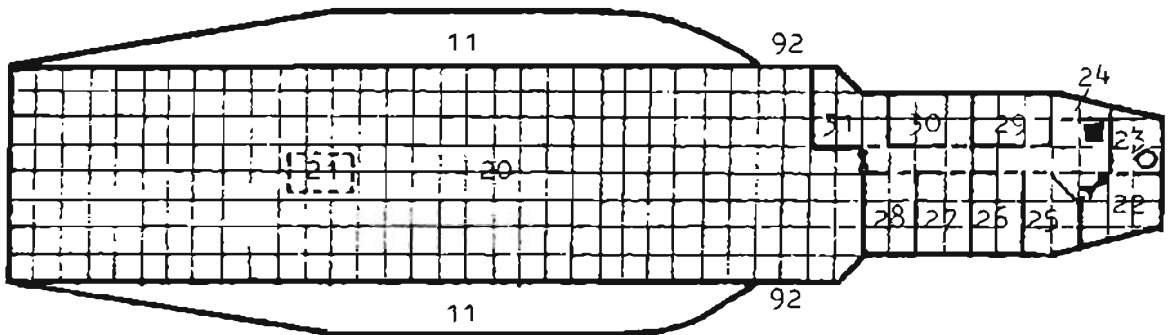
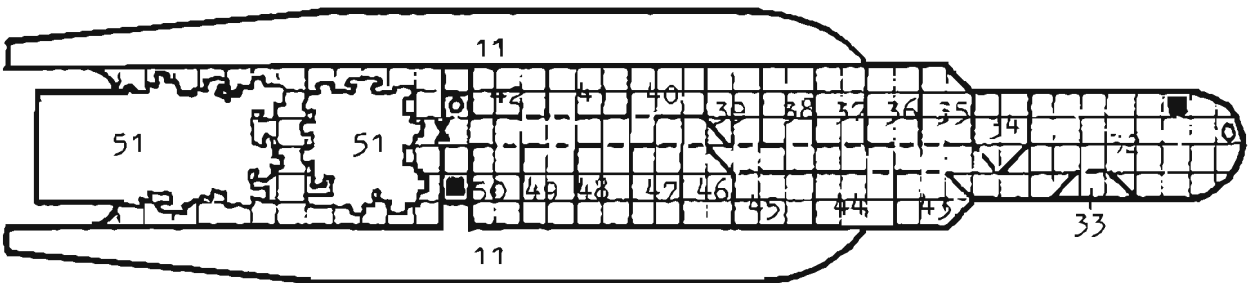
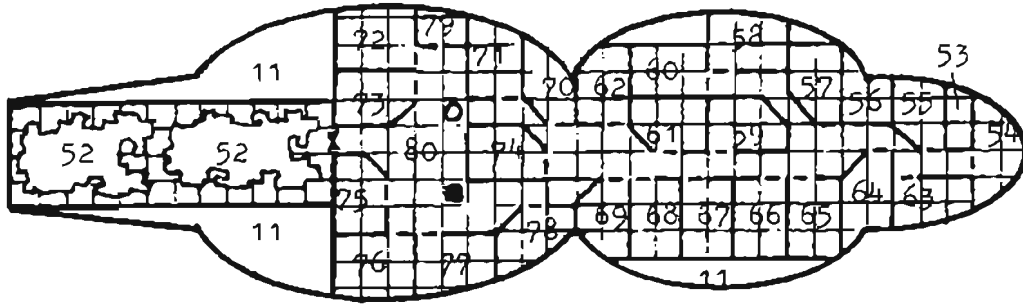

# DPRES SUBSECTOR

The Dpres subsector is named after its first human-colonized world. There are no multi-world governments in the area, but there are 3 Imperial client states. The coreward end is dominated by the outrim Void, a large, almost starless dust cloud (also known as the Trojan Blight).

The population of the Dpres subsector is largely Imperial human, with some Aslan on Torrance, Delta Theta, and Lacidaeus.

291-540 (0206) is a barren world due to its ocean -- the planet is completely covered in a corrosive sea of nitric acid. The starport is an automated orbital facility built by the Imperium as a link on the trade route to the Florian League.

DOSTOEVSKY (0308) is the location of an Imperial research station investigating an underwater Ancient site.

TORRANCE (0409) is a charismatic dictatorship led by one "Righteous John," who dragged the planet back to some degree of civilization after a devastating series of solar flares destroyed its oceans.

THALASSA (0803) has 98% hydrographics. Most of the world's population lives in huge, organic floating cities.

TLAZOLTEOTL (0704) was originally settled by Terran refugees from Central America. It is now governed by a council of philosopher-kings who derive their power from ancient Aztec myths (much as ancient Terran kings claimed to be representatives of God).

Solaria	0104	B665734-8	Agricultural.	
Dpres	0105	B631689-A	Non-agricultural. Non-industrial. Poor.	G
Connaught	0205	D431153-9	Poor. Non-industrial. Low population.	
291-540	0206	CABA000-0	Fluid hydrographics. Barren.	G R
Gabriel	0304	C210100-8	Non-industrial. Low population.	G
Dostoevsky	0308	B678673-A	Agricultural. Non-industrial. Research station.	
Janus	0406	C375321-7	Non-industrial. Low population.	
Torrance	0409	E8607AD-3		G
Delta Theta	0410	B701610-9	Ice-capped. Non-agricultural. Non-industrial.	G
Caldos	0507	B630879-6	Non-agricultural. Non-industrial. Poor.	G
Lacidaeus	0509	D100786-5	Vacuum world. Non-industrial.	G
Sagan	0607	C796453-8	Agricultural. Non-industrial.	G
Tlazolteotl	0704	D5409CD-7	Industrial. Poor. Desert world.	G
Tyr	0708	A551557-8	Non-industrial. Poor.	G
Hecarda	0709	B560332-9	Desert world. Non-industrial. Low population.	G
Thalassa	0803	B88A889-8	Water world. Rich.	G
Tktk	0808	D142640-7	Poor. Non-industrial.	G
Acis	0809	B885796-A	Agricultural. Rich.	G

The Dpres subsector contains 18 worlds with a total population of 5.458 billion. The highest population is 9, at Tlazolteotl; the highest tech level is B, at Gabriel and Tyr.

Back Issues

#1.....reprints available  
 #2.....reprints available  
 #3.....reprints available  
 #4.....sold out  
 #5.....sold out  
 #6.....still available

TRAVELLER STARSHIP COUNTERS

Each set contains 140 2cm X 2cm counters.

T

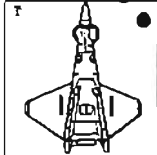

LANTIER



A

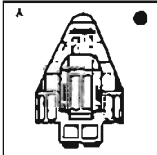

Send \$3.00 Canadian per set to Mike Jackson, No.512, 4676 Yew St. Vancouver B.C. Canada. V6L 2J6.



**MAP LEGEND**

**WORLD CHARACTERISTICS**

- Water present
- No water present
- ☄ Asteroid belt

**BASES**

- ★ Imperial naval base
- ▲ Imperial scout base
- ▼ Scout way station
- A Research station
- ☆ Foreign naval base
- Foreign military base

**TRAVEL ZONES**

-  Amber zone
-  Red zone

**POPULATION**

Secundus under one billion  
 PRIMUS over one billion

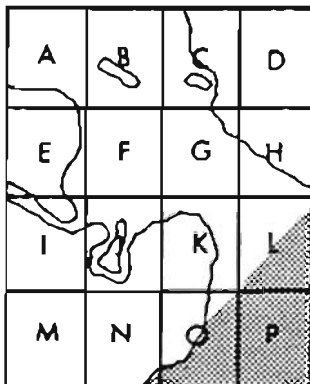
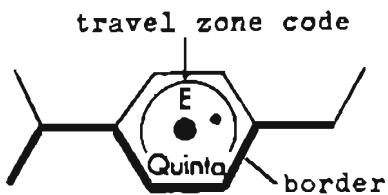
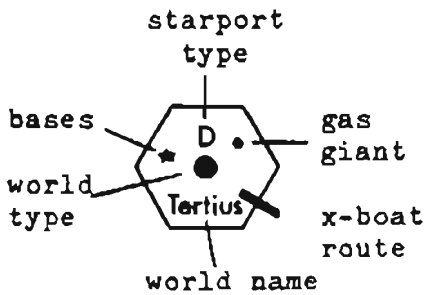

TROJAN REACHES SECTOR

**EGYRN**

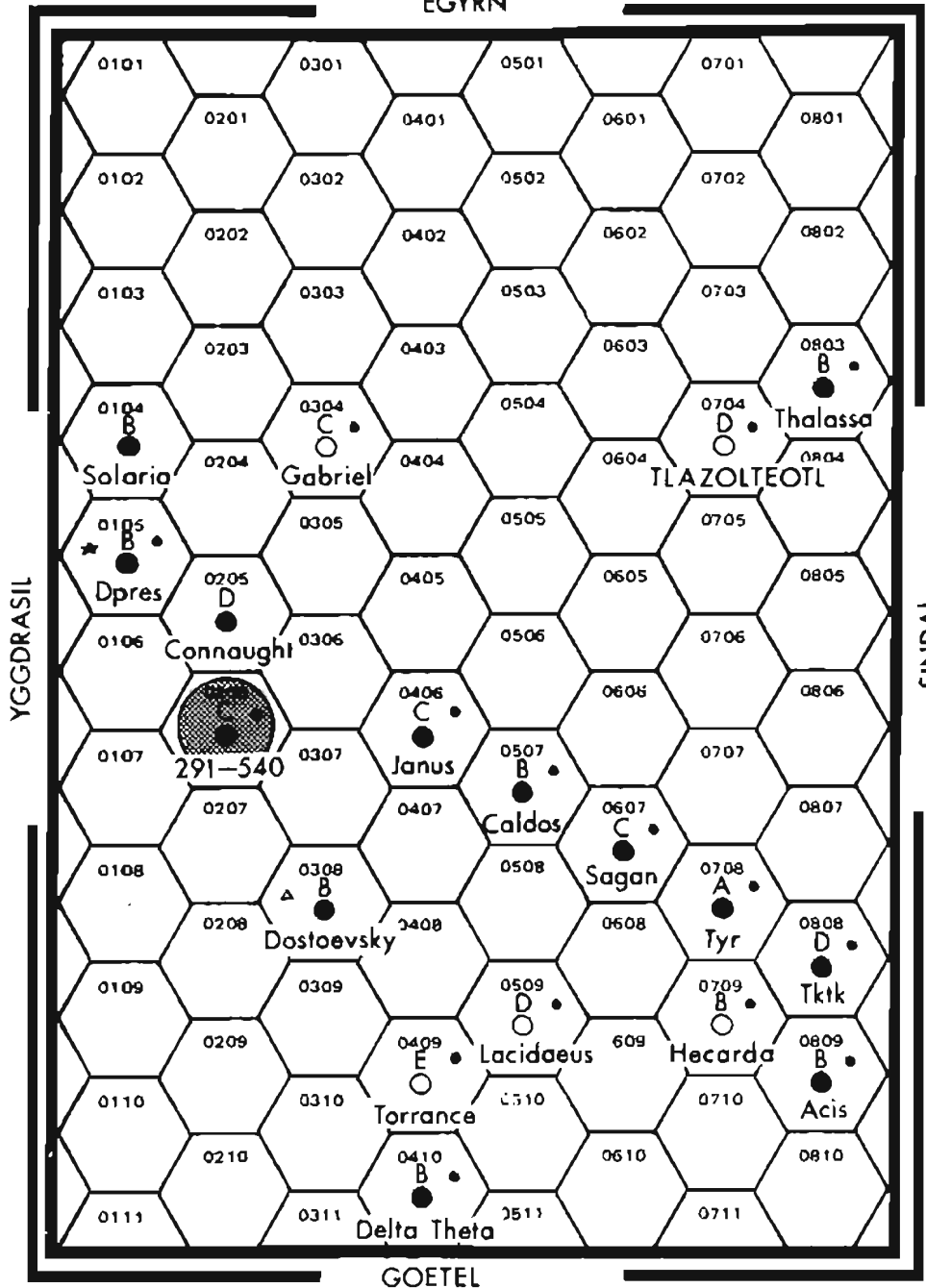

A: Menorial	I: Nora'a
B: Egyrn	J: Goertel
C: Pax Rulin	K: Tlaiowaha
D: Gazulin	L: The Borderland
E: Yggdrasil	M: Ranib
F: Dpres	N: Silraaihe
G: Sindal	O: Ekea'as
H: Tobia	P: Binary

# FEATURE ADVENTURE: THE GABRIEL PROJECT

Gabriel (Dpres 0304 C210100-B) is a small, barren world lying just outside the Imperium. Fifteen years ago, it was the site of an Imperial research station, but in 1105, the station was moved to Dostoevsky without explanation. Gabriel, whose only remaining importance is as a minor stepping-stone on the Imperial-Floridian League trade route, was left with a tiny population of 70 miners and starport personnel.

The players arrive in system as usual and are hailed by automatic beacons. However, they are unable to establish communications with any living beings. Gabriel has no orbital starport, so they are forced to land at its downport and only settlement, Armageddon City.

The city is a small collection of buildings lining a single road to and from the starport. All are individually pressurized to compensate for the trace atmosphere. The starport contains two ship's boats and a shuttle.

Arriving at the city, the players find no sign of life. Power is on, vehicles sit in the streets, food lies half-eaten next to open magazines, but not a single person is to be found. It is almost as if the entire population of Gabriel had simultaneously vanished.

In several places around the city, on a few doors, on a few scattered tables, the players notice the claw marks of a huge, six-fingered hand.

## WELCOME TO GABRIEL

As the players mill about the town, one of them spots a cloud of dust moving down the road towards Armageddon City. In a few minutes, a heavily damaged ATV drives up and smashes into the side of a small building.

The ATV is driven by a short, badly wounded young man. If the players draw near he will mutter, "Gabriel has come! He blows his trump of doom and the universe is laid waste! We are like dust -- the archangel cometh!" He then shudders and dies.

The man's ID shows him to be Dr. John Suulashkur, a scientific investigator for a small geneering (genetic engineering) firm. The ATV shows many scratches and dents, and looks as though in several places it has literally been ripped apart by immense hands. Closer inspection will reveal that the hands have six fingers. Inside one storage locker is a small laser device and a notebook.

The laser fires a low-powered beam in coded pulses. If the players read the notebook, they will notice that it is divided into two main sections. The first is comprised of neat notes on an expedition by Suulashkur to find the old Imperial research station, noting that it was found some 30km southwest of Armageddon City. It mentions a special "key" to something called the "barrier." Then, in what is recognizably the same hand, but somewhat altered, it rants about



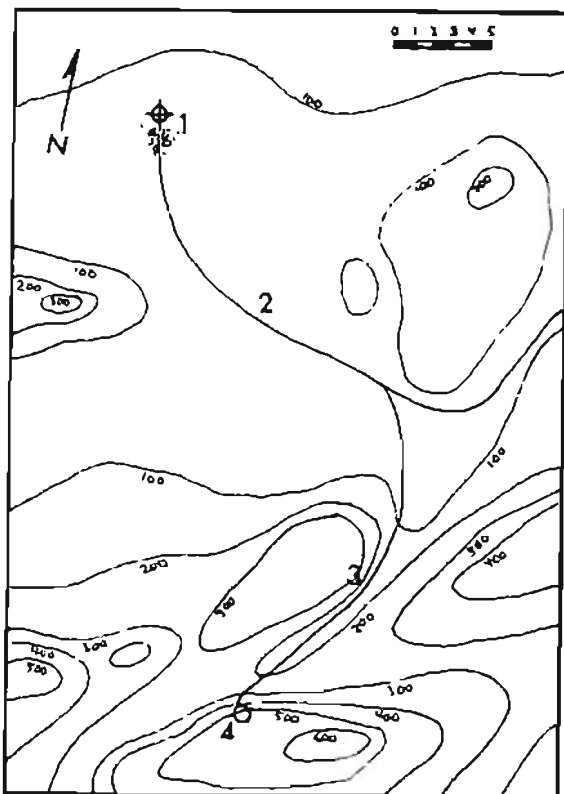

"the Gabriel Project" and quotes from an old religious text dealing with the end of the world.

#### DEATHQUEST

Setting out to investigate the old research station, the players follow the only road out of Armageddon City (#1 on the map). After about 20km, a side road branches off the main one (#2 on the map). It is partially blocked by a smashed road barrier; lying face down in the dirt a few metres away is a sign:

IMPERIAL RESEARCH STATION  
 DELTA  
 Authorized Personnel Only

The side road enters a range of mountains, and after 11km is blocked by a huge rockslide (#3 on the map). Off to the side is a small pressure tent and a bit of equipment; some of it is labelled with Suulashkur's name. Anyone with demolitions skill will realize that the landslide was man-made, and occurred several years ago.

If the players are using a grav vehicle, they may continue as normal; otherwise, they must proceed on foot. 10km later, the road ends, and a large building can be seen jutting from the cliff (#4 on the map).

#### INTO THE EARTH

The large vehicle bay doors have been pried open, and the airlock still works. The inside of the main complex is pressurized, but lacks power. Slicing through the complex (shown on the map as a large circle) is a large, completely opaque, impenetrable, black surface. It is actually a Black Globe, and determining its nature requires a UTP.

To determine that the wall is a Black Globe: Difficult, Gunnery, Imperial Navy Service, Instant, Uncertain

The Black Globe is totally black, ice cold, and cuts right through papers, tables, even an empty soft drink bottle. If the players fire the laser device from the ATV at it, the Globe will disappear for a period of 20 seconds. A measuring device is attached to the Black Globe mechanism, and whenever that specific pattern of energy is absorbed, it turns off. The floor on the far side of the Black Globe is about half a centimetre lower due to the settling of the complex by about a millimetre each time the Globe is turned off.

#### COMPLEX LOCATIONS

1. Vehicle Bay. This area is unpressurized, and contains two air/rafts and an AFV.
2. Lift Platform. Rises up to landing pad on roof.
3. Airlock. This is hooked up to a fusion generator in the vehicle bay, and so works normally.
4. Storage Locker, Empty.
5. Troop Ready Room.
6. VRF Gauss Gun Emplacement.
7. Ammunition Bay.
8. Reception. This room is very comfortable, with soft couches, old magazines, and plush carpeting. One couch has been snapped in two.
9. Office area. Contains several desks, chairs, and papers, and is in a complete shambles. There are bullet holes in several places.
- 10.-12. Offices.
13. Storage. Contains stationary, spare parts, and several boxes of food, all ripped open and all empty.

14. Repair Section. This room holds a disassembled air/raft, and there is evidence of an explosion. Off in one corner is a TL 15 vacc suit. However, it is 3 metres long, malformed, and has four arms.
15. Lab Space. Contains a multitude of scientific equipment, all related to genetic engineering.
16. Medical. This room holds several beds, medical equipment, and an LSP med robot, the latter sliced in half by the Black Globe.
17. Records. There has obviously been a fire here, and little of the material appears intact. However, one piece of paper, a progress report dated 1104, refers to "certain complications in the behavior of A.G.E. 5." Players with scientific background will recognize A.G.E. as standing for Android Genetic Engineering.
18. Conference Room. The Black Globe slices right through the centre of the room.
19. Common Area. This has obviously been the site of a major battle. The room is demolished, with signs of gunfire, lasers, a grenade blast, and huge slash marks.
20. Galley. All the food has been removed, leaving empty cans and demolished packaging.
- 21.-36. Staterooms. Some are in good condition, while others have been totally wrecked.

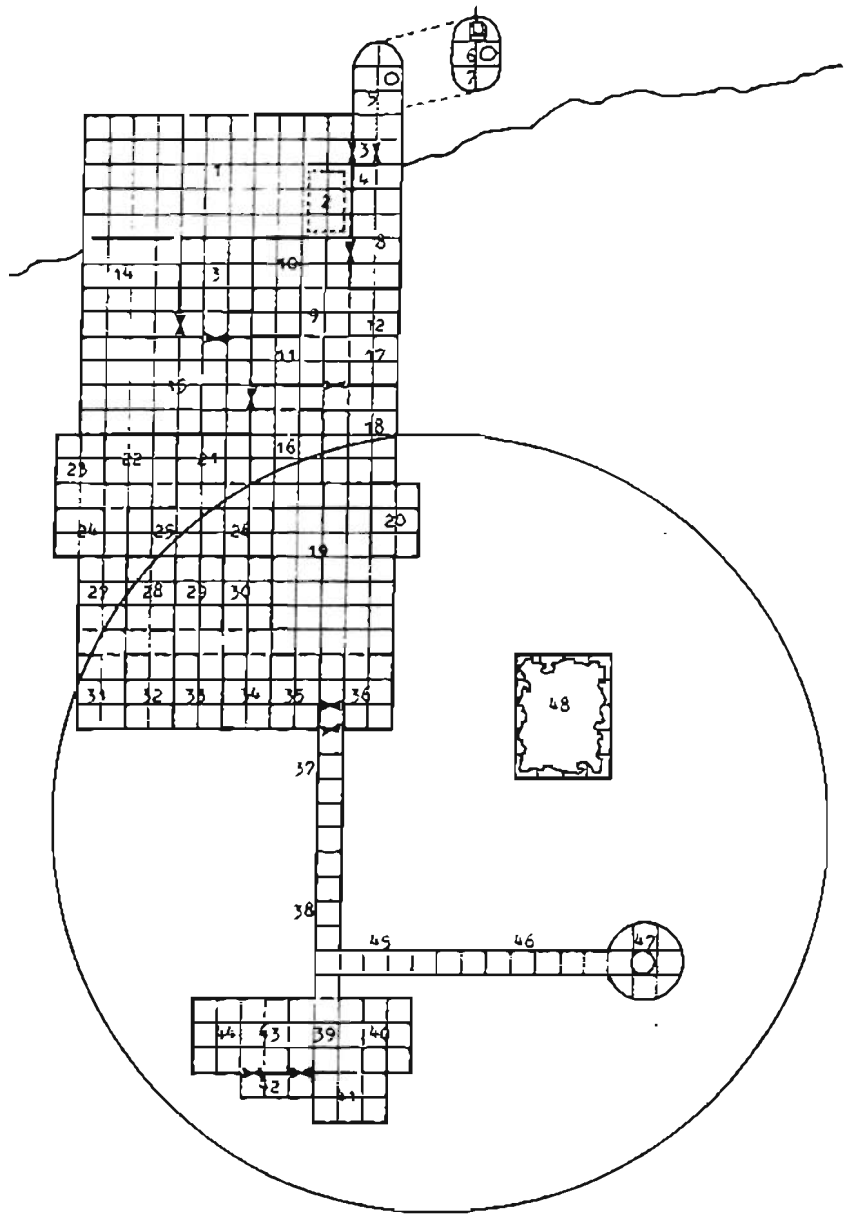

37. A sign on one wall of the corridor says "Gabriel Project Labs" with an arrow pointing down the hall.
38. Painted on the wall here in fluorescent orange is a makeshift sign, saying, "Warning. Extreme Danger. Do Not Continue On Penalty Of Death."
39. Behind a locked steel door are several chairs and a security station.
40. Android Vat #1. Can be recognized with the following UTP.  
To recognize android vat: Difficult, Genetics, Education, Instant, Uncertain.
41. Android Vat #2.
42. Access Way.
43. Gallery. A glass wall with a large hole looks into the nursery.
44. Nursery. Contains a bed (3m long), toys, a computer console

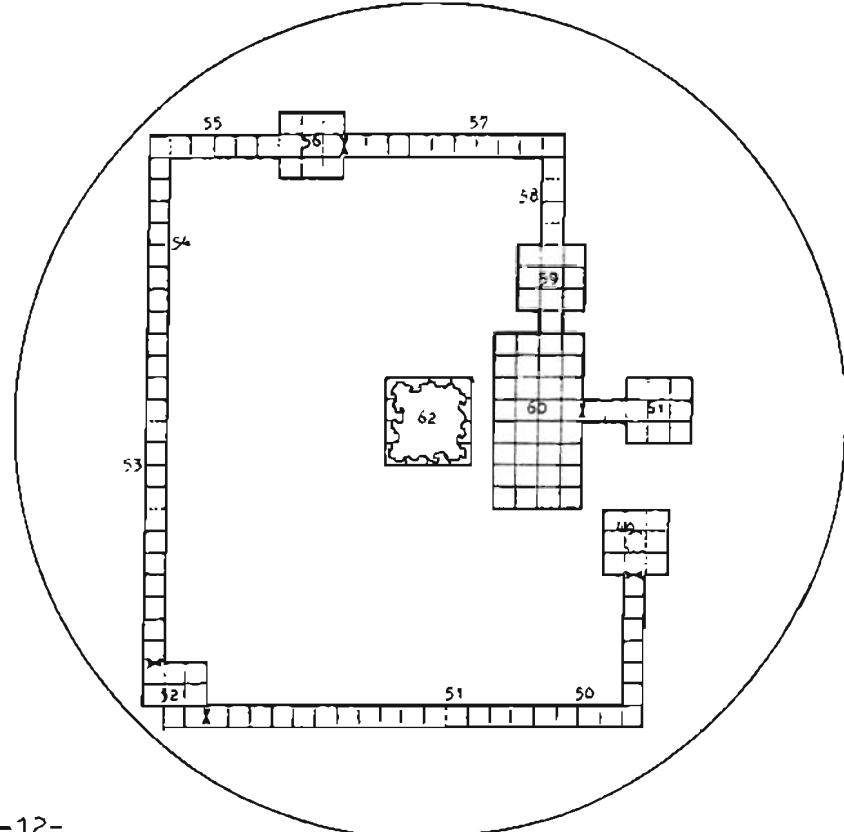

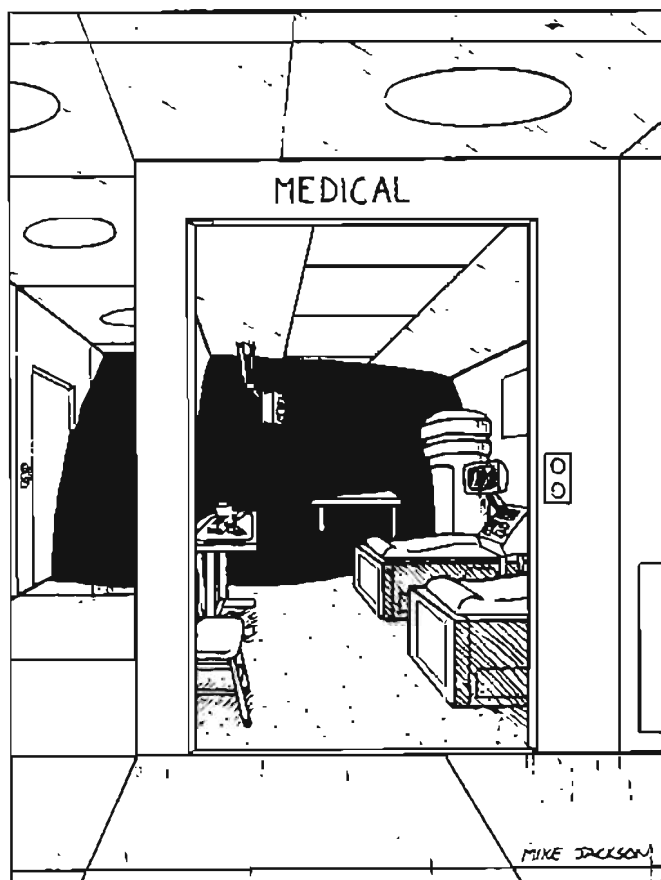

and many books. Most of the books are religious texts (eg, the Bible, the Koran, the Melhei, etc.) or commentaries thereon.

45. Heavy Steel Doors. Each one is locked, the first with a keypad, the second with a thumbprint, the third with a retinal scan, and the fourth with a key. Opening each requires a UTP.

To open doors: Difficult, Electronics, Mechanical, 15 seconds.

Referee: There is an automatic +1 DM on the first door and a -1 DM on the third, and a lockpick set is required on the fourth.

The doors require 100 damage points to break through.

46. The floor here has alternating red and white tiles. All red tiles are electrified (2D damage). To cross only on the white tiles requires a roll of dexterity or lower on 2D.
47. This round room contains more warning signs and a large shaft going down 20 metres. It is perfectly smooth, with no handholds of any sort.
48. Power Plant.
49. At the bottom of the shaft are two super guard robots (101 Ro-

bots, #72). If the floor is touched by any weight greater than 10kg, they will become activated.

50. A tripwire here activates gas jets. The gas is mildly paralytic, and does 3D damage to any who breathe it.
51. A floor plate here causes two doors to drop and the ceiling to begin to lower. It can be stopped by picking the lock on the far door.
52. The doors to this room close automatically when the players enter, and the air begins to rush out. It will become a vacuum in 30 seconds.
53. Grav plates in the floor here create a 4-G zone. Anyone stepping here will fall, taking 1D damage, and be completely immobilized. To get out without help, roll strength or lower on 4D.
54. Sonic weapons project a beam from the wall. Anyone not wearing headgear must roll endurance or less on 3D to continue moving.
55. The tunnel here slopes down. If anyone gets halfway down, jets will spew out riot foam (totally frictionless, T.I. #4), and flames will ignite in area 56.
56. Flames from floor jets here do 2D damage.
57. An infrared beam here triggers a corrosive gas, which not only does 3D damage to all who breathe it but also affects vacc suits and armour.
58. A hologram here disguises a pit as an ordinary floor. If a player falls in, the pit closes up, trapping him.
59. All the walls in this room are reflex covered. When both doors are closed, a laser rifle will fire a beam, which will ricochet until it hits someone. Roll to hit -2, and continue until someone is hit.
60. Throne Room. This room is very large and filled with junk: jewelry, credits, cutlery and odd trinkets. In the centre is a large makeshift throne, and in it sits Fyve (A.G.E. 5), expecting the party and welcoming the challenge they offer.
61. Cold Storage. This room is one big low berth, and holds most of the city's population.

## THE GABRIEL PROJECT

In 1098 Research Station Delta was set up on Gabriel, its main subject of research being genetic engineering, particularly the military applications thereof. In 1103, various technicians from *Imperial Geneering*, *LIC* joined the team of scientists, and A.G.E. 5 was designed and grown. Intended as a super-soldier in the event of a Fifth Frontier War, he was quickly brought to maturity and educated. He showed a special interest in religious literature, and appreciated the irony of the planet's name in relation to himself.

However, Fyve, as he styled himself, proved to be mentally unstable, with tendencies toward excessive violence and megalomania. In 1104 he killed and ate one of his technicians; finding the taste delicious, he went on a rampage. It eventually took 10 Imperial Marines in battle dress to stop him, but even they could not destroy him. A special prison was built, and he was placed in cold sleep inside a black globe. A special laser key was built and hidden in case access was later necessary. The research station was then moved to Dostoevsky.

Two months ago, Dr. John Suulashkur found the complex and gradually made his way through. He found Fyve and released him; Fyve subsequently captured him and the entire population of Armageddon City, convincing them all that he was in fact Gabriel and driving many, including Suulashkur, insane. Since then, he has been munching away on the populace and waiting for a jump-capable ship to arrive in which he can leave the planet. After detecting one's arrival, he allowed Suulashkur to escape (though not without a fight), knowing he would lead people to the research station.

### FYVE

Fyve has a U.P.P. of KKKFAK, with the final digit denoting psionic strength. He has all psionic abilities to level 10. He is 3 metres high, and looks like a man-machine hybrid. The two larger of his four arms end in huge scythes (hit as broadsword, 4D+3 damage), the other two ending in six-fingered hands.

Intelligent, playful, and dangerously insane, Fyve is very clever and possessed of a strong (though morbid) sense of humour. He can best be played as a cross between Lex Luthor and Darth Vader.

Fyve has the following skills: Scythe-2, Brawling-1, Computer-1, Demolitions-1, Electronics-1, Gravitics-1, Combat Rifleman-1, Energy Weapons-1, Hunting-1, Interrogation-1, Jack-of-all-Trades-3, Mechanical-1, Pilot-1, Stealth-1, Tactics-1.

When the players first see Fyve after having worked their way past all the traps, he is casually munching on a human leg. After offering a chunk to them and expressing disappointment when they refuse ("It's very delicious, really -- it tastes rather like smoked ham."), he will explain who he is, talk about his history, and tell the characters why he wants them, occasionally throwing in an obscure religious reference. If the players attack him, or when he has finished speaking, he will declare that fun time is over, and viciously attack the players. The final outcome is up to the referee; Fyve makes an excellent long-term villain, so it may be good to allow him to escape.

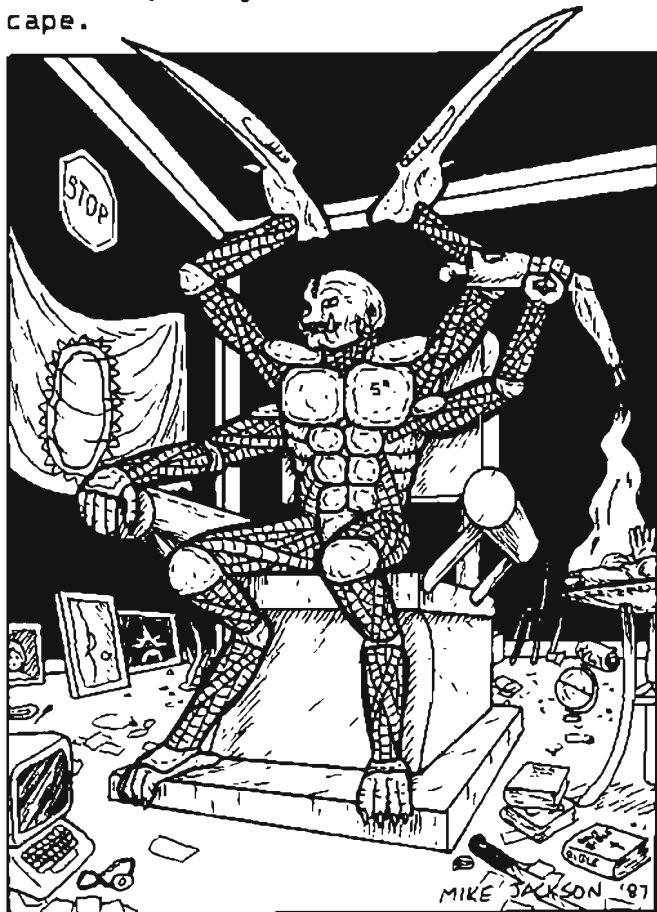

# IMPERIAL NAVY UNIFORMS

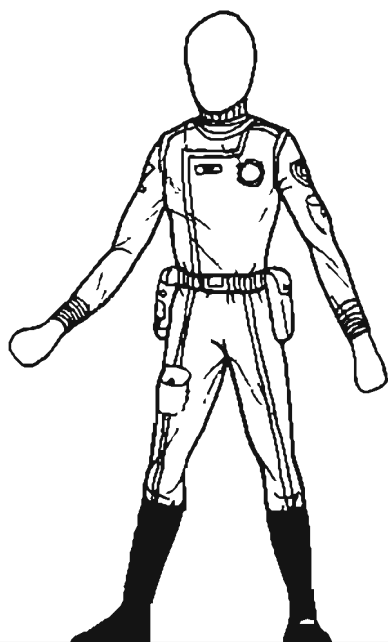

Duty

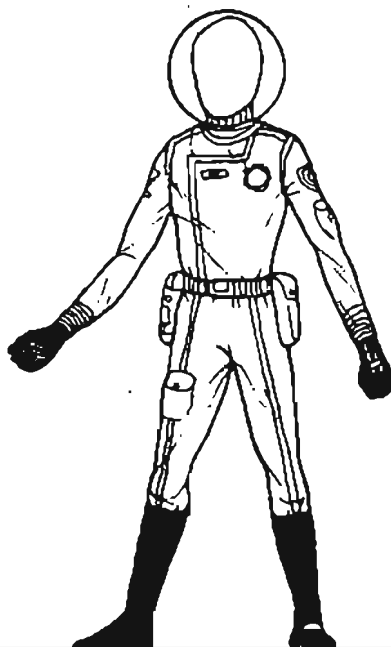

Duty (Vacuum Mode)



Dress

## RANK INSIGNIA

none      Spacehand Recruit



Spacehand  
Apprentice



Able Spacehand



Petty Officer  
Third Class



Petty Officer  
Second Class

1 additional pip per level

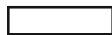

Ensign



Sublieutenant



Lieutenant



Lt. Commander



Commander



Captain

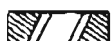

Commodore



Admiral  
(plus pips)



## BRANCH INSIGNIA



TECHNICAL SERVICES

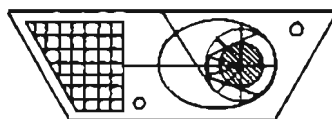

CREW/LINE



ENGINEERING

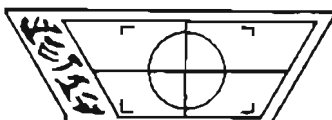

GUNNERY



MEDICAL



FLIGHT

# TRAVELLER'S HARDWARE

## HOLOSUIT

Designed by Duncan Torrance

The holosuit is a rare device used for disguise. Perfected at TL 15, it combines a wrap-around holo-projector and a voice modulator, allowing the wearer to look and sound exactly like any other person.

The holosuit is programmed by insert crystals, bearing the image and voice patterns of an individual. Generally, they are only available in blank form, but can be programmed by making a five-minute recording (voice and holo) of the desired individual (preferably live, but also possible from TL 15 holo viewers). Pre-programmed crystals are also available on the black market, but are extremely expensive and often illegal.

The holosuit can play one image (using a computer to adjust it to the wearer's movement), and has a storage compartment for four more insert crystals.

Detecting someone wearing a holosuit requires a roll of intelligence or lower on 4D, DM-2 if the observer knows the patterned individual, DM-6 if he knows him well. A holosuit can automatically be detected if anyone touches the individual, as what he feels will not correspond with what he sees.

The holosuit costs Cr600 000 and weighs 4kg. It can be worn over any armour except combat armour, battle-dress, and TL 9-12 vacc suits. Blank insert crystals cost Cr50 each, and preprogrammed ones run from Cr800 up to Cr5000 on the black market.

## TYPE D PREFAB STARPORT

Based on original designs used by the IISS, the prefab starport is currently built and marketed by Frontier Development, LIC. Available at most TL 13+ and starport A worlds, it is used by businesses, governments, and independent individuals in any situation where an easily and quickly built starport is necessary.

The prefab starport consists of the following items:

- 1 Advanced base
  - 1 Radio beacon/transmitter
  - 1 Pulse laser installation
  - 1 Collapsible (200 ton) fuel storage tank
  - 1 Warehouse tent
  - 1 Mechanical toolkit
  - 1 Electronic toolkit
  - 1 Fusion power plant
  - 1 Dirt-mover
  - 8 Industrial size canisters of steel foam
  - Miscellaneous measuring instruments
  - Plans and instructions
- Total cost: MCr1.13  
Total weight: 30 tonnes

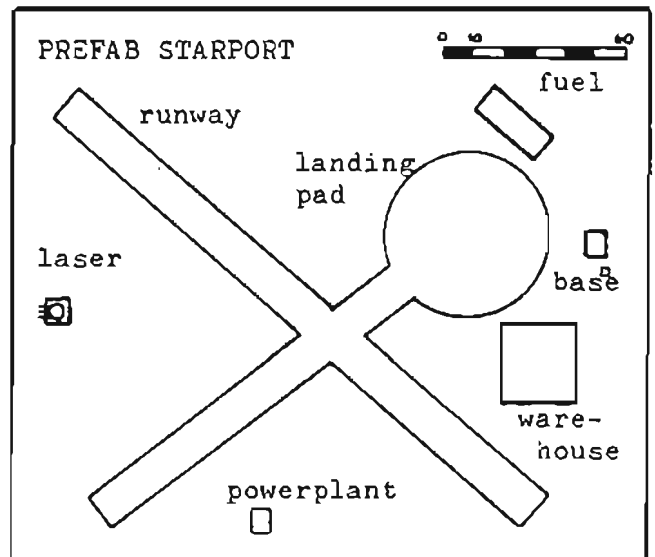

The prefab starport comes packed in various crates for easy transport aboard a starship. Once it is placed upon a planet, construction can begin, by the following steps:

1. Find a large, flat, clear area (rock plateau, field, clearing) approximately 1km by 1km in size, and preferably located near water. Ground must be firm.
2. Clear the area of all vegetation or obstacles (rocks and trees) with the dirt-mover and toolkits.
3. Using the dirt-mover, dig (10cm deep) the runway/landing pad base.
4. Fill the pad base with steel foam. Smooth out.
5. Place buildings, beacon, etc.

Construction of the prefab starport requires approximately 200 man-hours.

*Continued on page 18*



# CUSTOMIZED STARSHIPS

Starships are very much like cars on ancient Earth: there are many different types produced by various manufacturers. But, also like cars, they can be and are modified by their owners to suit certain needs. Such changes in a starship can vary from a new paint job to additional equipment to a major reworking of the drives.

Traveller and Adventure 5, Trillion Credit Squadron, dealt with certain changes: upgrading turrets, changing weapons, replacing systems, and various types of demountable and permanent fuel tanks. But these make up only a small fraction of the possible changes that can be made.

All of the following modifications can generally only be performed on ships of 1000 tons or less.

## PERFORMANCE

A ship's performance can be altered in a number of ways. Drives (manoeuvre, jump, and power plant) can be customized through the use of special parts (an extra capacitor here, a higher grade jump coil there, etc.). All of these modifications require extra maintenance (Engineer-3, at least once every two months.)

A starship's power plant can be adjusted to provide a bit of extra power (just like a car's engine); for 1 week's work and 3% of its initial cost, it can give 10% extra EP's. Requires Engineer-3.

The jump drive can have its fuel consumption dropped by 10% (of fuel tonnage, not of ship tonnage). Cost is 4% of jump drive cost. Requires 2 weeks and Engineer-3.

Acceleration can be increased by .5 G's through proper maintenance and modifications. Cost is 10% of manoeuvre drive cost. Requires 2 weeks and Engineer-4. Travel times can be calculated using the formula in Traveller.

A ship's sensors can be upgraded to military standards at 20% of bridge cost. Such upgrading includes extending EMS sensors into the long-wave radio band and the addition of mass, neutrino, and NAS sensors. Re-

quires 1 week and must be performed at a type B starport.

Computers can be improved by the use of higher quality components and better care. CPU/storage is raised to the next level (model/1 to model/2, model/1 fib to model/2 fib, etc.). Requires 2 weeks and Computer-4. Cost is 50% of computer cost.

## DEFENCE

Beam weapons can be adjusted to increase power output. Cost is 40% of weapon cost. Requires 1 week and Gunner-3. Weapons will do double damage and use double the EP's.

A ship's hull can be electrified to deter animals (and people) from touching it. Cost is 1% of hull cost. Must be performed at a starport. Takes 1 week.

Video cameras can be installed inside and outside a starship. Immobile cameras cost Cr500, while mobile ones cost Cr1200. Must be linked to a DCS (below).

Laser rifles can be fitted to the outside of a ship's hull for use against personnel while on the

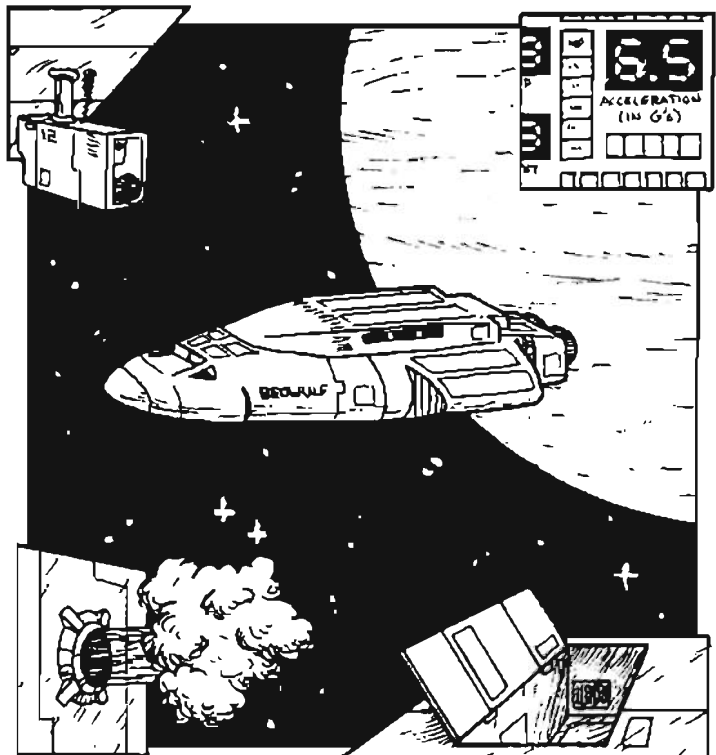

MIKE JACKSON '87

ground. Cost is Cr5000. Installation requires Laser-3, Mechanical-1 and Electronics-1, and takes 3 hours. Must be linked to a DCS and a video camera.

Laser carbines can be set up inside staship areas. Cost is Cr3000. Installation as for external laser rifles. Must be linked to a DCS and video camera.

Tranquilizer gas jets can also be installed inside a starship. Cost is Cr400. Must be linked to a DCS and video camera.

An alarm system can be installed for Cr2000. Sensors are placed throughout (both inside and outside) the starship, and are keyed to an alarm. Requires a DCS.

A Defence Control System (DCS) is a monitor and control system for the specified items above. Costs Cr5000. Requires Electronics-3 and 1 day to install.

Various types of locks are available for a starship. Full descriptions are given in JTAS #18. All require 1 hour and Electronics-1 to install. Keypad: Cr40. Magnetic reader: Cr50. Fingerprint: Cr50. Voiceprint: Cr75. Retinal scanner: Cr75. Metabolic scanner: Cr200.

Heavy weapons (VRF Gauss gun, Autocannon) can be set up to fire out cargo bay doors (for use against personnel). Cost is 1.5 x original weapon cost. For an extra Cr1000, they can be built to rise out of a hidden floor compartment. Requires Weapons-2 and Mechanical-2, and takes 3 days to install.

## MISCELLANEOUS

All starships carry radio communication systems. Military ships also carry maser and laser communicators, which cost Cr25 000 and Cr50 000 respectively. Maser communicators cost Cr1 and weigh 2 tons. All require Communications-2 and Electronics-1, and take 2 days to install.

ECM (Electronic Counter-Measures) packages cost Cr300 000 and take 3 days to install. Requires Electronics-3.

Radio/radar jammers cost Cr200 000 and have a 10 000km range. Requires 1 day and Electronics-1 to install.

A multi-transponder with 3 different I.D. codes can be purchased for

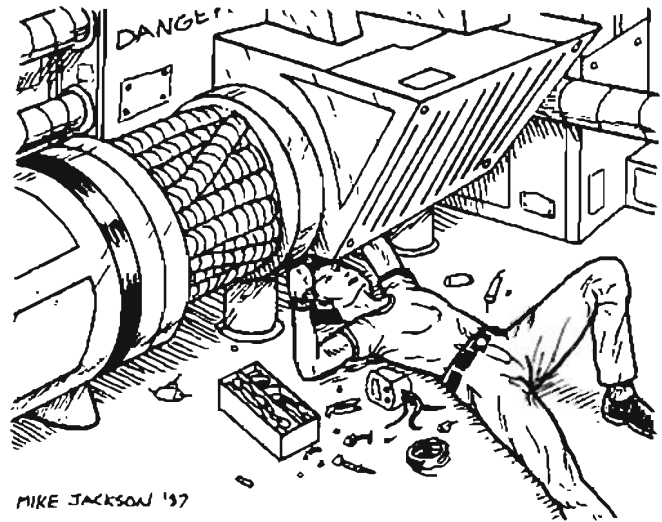

MIKE JACKSON '97

Cr300 000. This is an illegal item, and requires Electronics-4, Communications-2, and 3 hours to install.

The interior of a starship (normal walls) can be reconfigured in any desired manner within the limits of bulkheads and other permanent components (drives, bridge, hardpoints, etc.). Cost is Cr200 per remodelled ton.

Other special facilities can be added as follows: Sick bay-4 tons, Cr30 000. Lab-6 tons, Cr20 000. Animal pen-1 to 10 tons, cost varying according to environment and size. Purification plant, as in High Guard.

Smuggling compartments can be built into a ship's floors. Cost is Cr50 per kg of space, to a maximum of 100kg. A ship may have no more than 100kg of compartments per 50 tons of non-fuel space.

At least 30% of all starships are customized in some manner. The most common modifications are video cameras and locks; the rarest are drive, computer, and weapon upgrades.

---

*Continued from page 16*

Prefab starports are usually found on newly colonized worlds, as outposts on other planets of a solar system, or even as pirate bases. They are naturally most often used on the frontier, and are thus unavailable in the older sectors (Core, Solomani Rim, etc.)

A prefab starport can handle up to 800 tons of ship, in any number of vehicles. It requires a crew of 3 (gunner, engineer, and manager/communications), and should be supported either by a food-producing village or quarterly supply deliveries. TL 13.

# TRAVELLER'S ADVICE

BUYING EQUIPMENT IS AN IMPORTANT PART OF TRAVELLER. THE DISCERNING PLAYER SHOULD ALWAYS WATCH FOR BAD DEALS AND FALSE ADVERTISING...  
(Part 2)

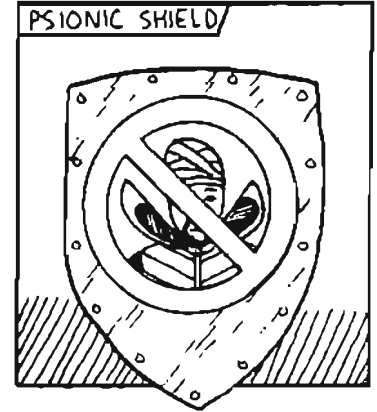
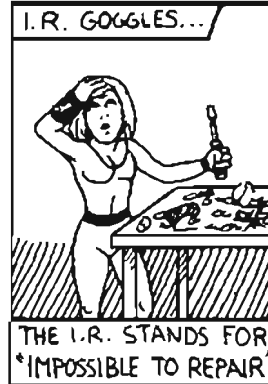
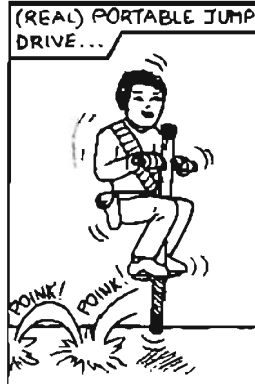
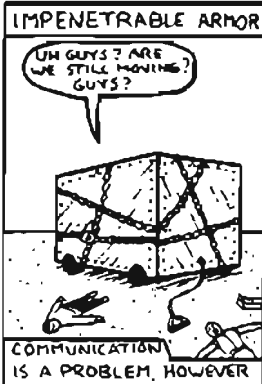

# INSIDE EQUIPMENT: DISINTTEGRATOR

TL-19

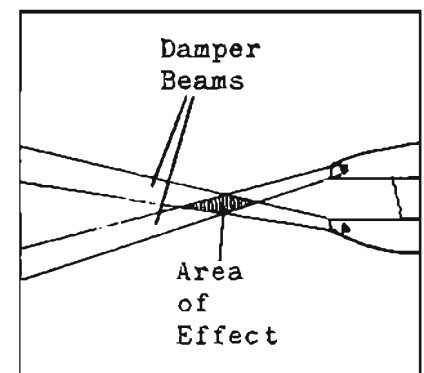
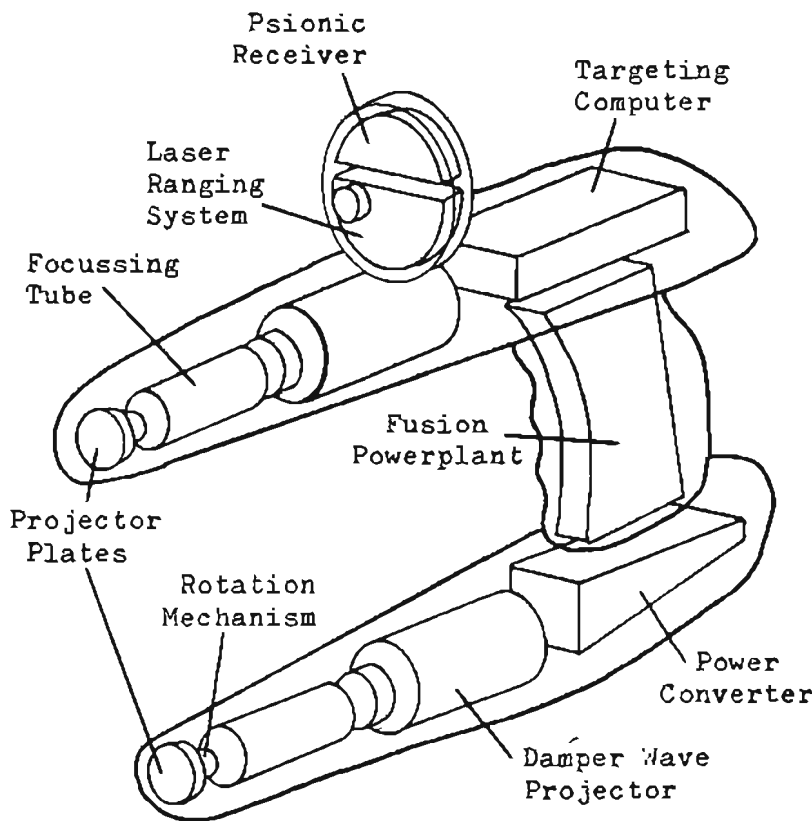

The Disintegrator Pistol is a high-tech Ancient weapon based on nuclear damper technology.

The Disintegrator generates two beams based on the nuclear forces (as lasers are based on electro-magnetic forces). At the point where they intersect an interference pattern is produced which suppresses the strong nuclear force. This causes the atoms to fly apart, disintegrating the target.

Length: 200mm  
Weight: 800g  
Base Price: Mcr1.5

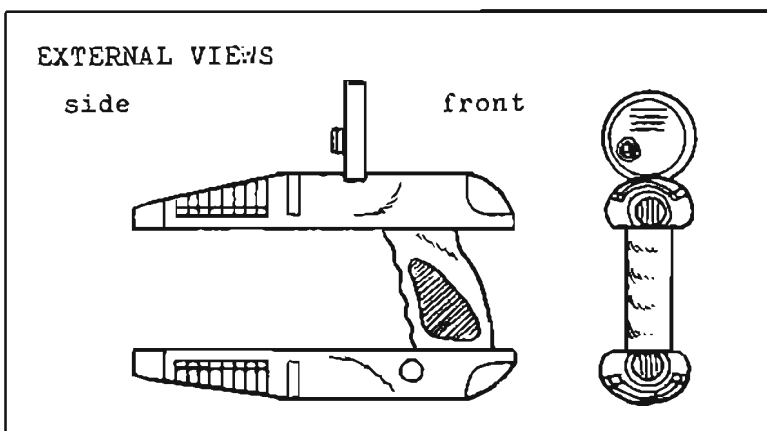

**NEXT ISSUE :**

Feature Adventure - Mindburst Provincial Merchant Yggdrasil Subsector

Plus the Florian League, Hi-Tech Equipment, and a set of Coyns!  
On sale in December!

# SENTRY BOX WEST

No.1 IN TRAVELLER LITERATURE!

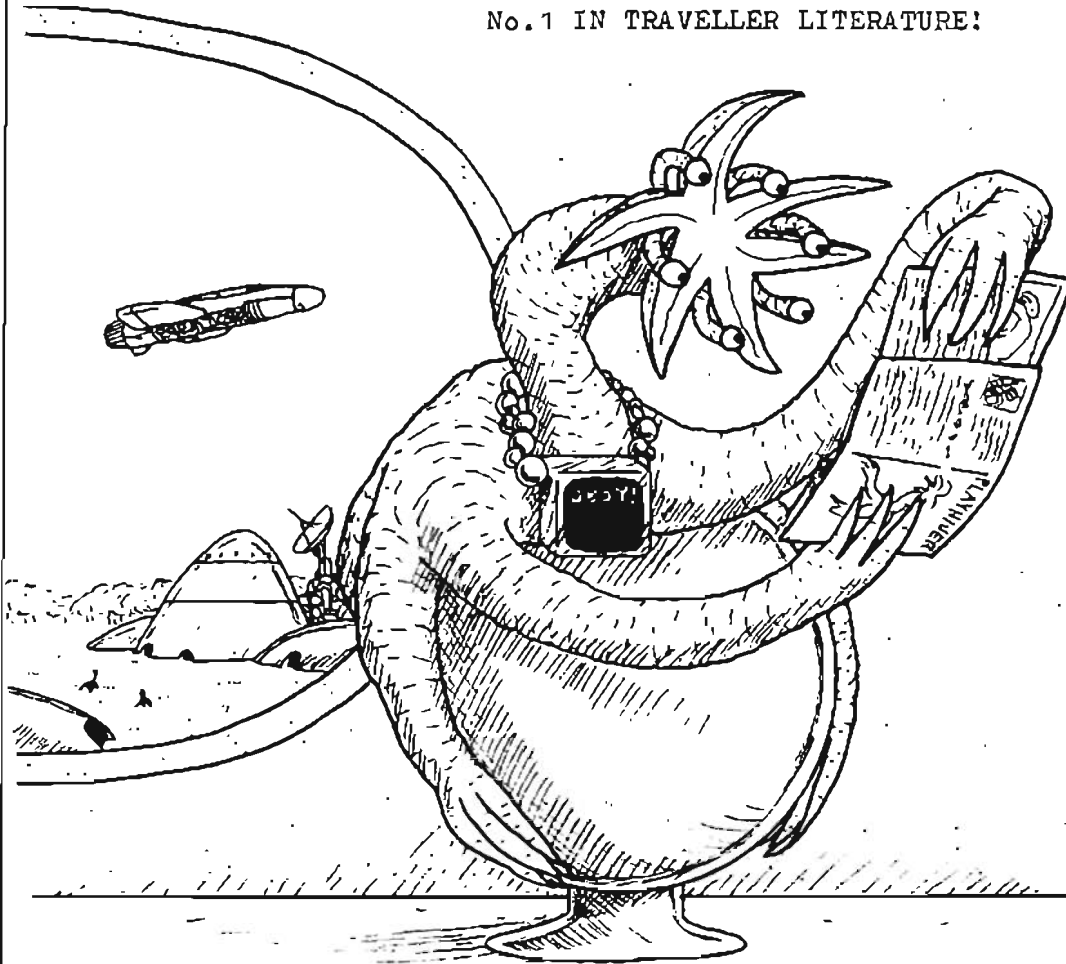

WE STOCK THE  
FOLLOWING LINES  
OF FIGURES:  
Ral Partha  
Citadel  
RAFM  
Minifigs  
Martian Metals  
Asgard  
Grenadier  
Frei-korps  
Stone Mountain  
Heroics and Ros  
Skytrex  
GHQ  
Naismith  
Dark Horse  
Off the Wall

WE SPECIALIZE IN ROLE PLAYING GAMES,  
BOARDGAMES AND LEAD FIGURES...

ESPECIALLY LEAD FIGURES!

We stock all the latest TRAVELLER supplements at reasonable prices!  
We also have back issues of Journal and hard to get TRAVELLER figs.  
IF YOU NEED SOMETHING JUST ASK!

## SENTRY BOX WEST HOBBIES

3309 West 4th Ave.  
Vancouver B.C.  
Canada  
(604) 734-1937



HIVERCARD accepted

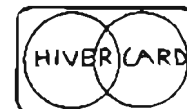

Don't leave your homeworld  
without it!

## COMING SOON:

FOR TRAVELLER: Challenge 29  
Traveller's Digest 9  
The Darrians  
Regatta

FOR 2300: The Aurora Sourcebook  
Pentapods  
Ships of the French Arm  
Starcruiser