

ISSUE # 8

# FIGURE PAINTER magazine

sculpting • painting • displaying • gaming

REVIEWS OF  
DWC's Judge Anderson  
GW's Mirkwood Rangers  
Roberto Chaudon's Diablito  
Nocturna's Uther Pendragon



**INSIGHT**  
interview with Rafael García Marín



[www.figurepaintermagazine.co.uk](http://www.figurepaintermagazine.co.uk)

DECEMBER 2013 £1  
ISSN 2052-8507



# Model Display Products ProPigments



Our pigments are finely ground Natural Earth Pigments and of the highest quality. Over recent years, earth pigments have become extremely popular with model makers who wish to achieve realistic and authentic looking finishes, especially with military and railway enthusiasts where a weathered look is far more desirable. The pigments are commonly mixed with thinners to create a paste or mixed with acrylic resins or varnish and glues to replicate urban, rural, industrial or warfare surface conditions like: dust, dirt, mud, rust or surfaces that are in state of damage or disrepair.

[www.modeldisplayproducts.com](http://www.modeldisplayproducts.com)

Available in ProPigment sets or individual pots.

Our pigments are not sold for cosmetic, pharmaceutical or food use. Use care when handling any dry pigment. Avoid inhaling pigment dust.

Model Display Products  
ProPigments

Figure Painter Magazine is published by  
Robot Pigeon Publishing. South Cheshire. UK



#### Contact Figure Painter Magazine

**Web** [www.figurepaintermagazine.co.uk](http://www.figurepaintermagazine.co.uk)

**Email** [info@figurepaintermagazine.co.uk](mailto:info@figurepaintermagazine.co.uk)

**Editor** Shane Rozzell [editor@figurepaintermagazine.co.uk](mailto:editor@figurepaintermagazine.co.uk)

**News Editor** Robert Monnar [news@figurepaintermagazine.co.uk](mailto:news@figurepaintermagazine.co.uk)

**Content Editor** Marko Paunovic [content@figurepaintermagazine.co.uk](mailto:content@figurepaintermagazine.co.uk)

**Sales** Sarah Evans [sales@figurepaintermagazine.co.uk](mailto:sales@figurepaintermagazine.co.uk)

**Proof Readers** Martyn Dorey  
Sean Fulton

**Reviewers** Marta Slusarska  
Mario B Delgado (mbd)  
Martyn Dorey  
Jake Cannon (Gamespace)

**Cover Artist** Rafael Garcia Marin

#### Other Contributors

Marko Paunovic, Martyn Dorey, Ana Polanscak, Andrija Jurisic, Lyn Stahl, Davide Rainone, Federico Sorgi, Alex Huntley, Tim Fitch



The views and opinions relating to all material herein does not necessarily reflect the opinions of Figure Painter Magazine staff, editors or publishers who are not liable of said opinions. Figure Painter Magazine cannot be held responsible for inaccuracies in any of its publications. Furthermore, responsibility for any losses, damages or distress resulting from adherence to any information made available through this magazine or its website is not the responsibility of Figure Painter Magazine or its publisher, Robot Pigeon Publishing. Adverts and advertisers appearing in Figure Painter Magazine carry no implied recommendation from the magazine or the publishers. Artwork has also been either taken from company websites pertaining to the image and may not be reproduced (except for personal use) without prior written permission from the said author / artist. Most product names are trademarks owned by the companies that publish those products. Photos sent to Figure Painter Magazine will be treated as offered unconditionally for publication and copyright purposes and are subject to editing and comments by the editors. Please ensure that all photos have credits attached if necessary. All rights reserved. No part of this publication may be reproduced without prior consent from Figure Painter Magazine.



Welcome to issue 8 of Figure Painter Magazine, the final FPM of 2013. In this issue, we have some great articles including an Insight interview with none other than Rafael Garcia Marin aka, Volomir. We also have a brilliant tutorial from award winning painter Federico Sorgi and the second part to Alex Huntley's sculpting tutorial. As usual, we also have our latest instalment to the gaming table build up and lots of reviews. Lyn Stahl, a new member of our contributor team, shows us her methods of getting inspiration for colour schemes and Martyn Dorey of Model Display Products tells us what's on the market for when we tackle basing and groundworks.

Also, in this issue we have a new feature called "Questions, Questions, Questions?" Where Tim Fitch — long time miniature collector and owner of Miniature Heroes, interviews influential people from the miniature industry, past and present. This feature kicks off with something special; an interview with the founder of Rackham and the creative force behind the Confrontation skirmish game, Jean Bey, who tells us of the last days of Rackham Miniatures.

I'd also like to take this opportunity to thank all of our readers for making 2013 a very special year and keeping FPM going. You people keep surprising us with your loyalty and we all wish you a very Merry Christmas and a Happy New Year.

Shane ©

**Web** [www.figurepaintermagazine.co.uk](http://www.figurepaintermagazine.co.uk)

**Email** [info@figurepaintermagazine.co.uk](mailto:info@figurepaintermagazine.co.uk)

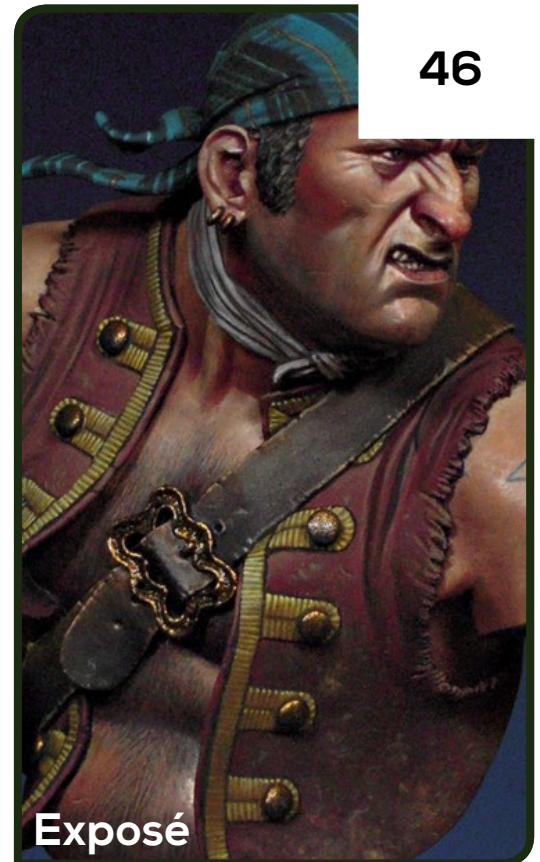
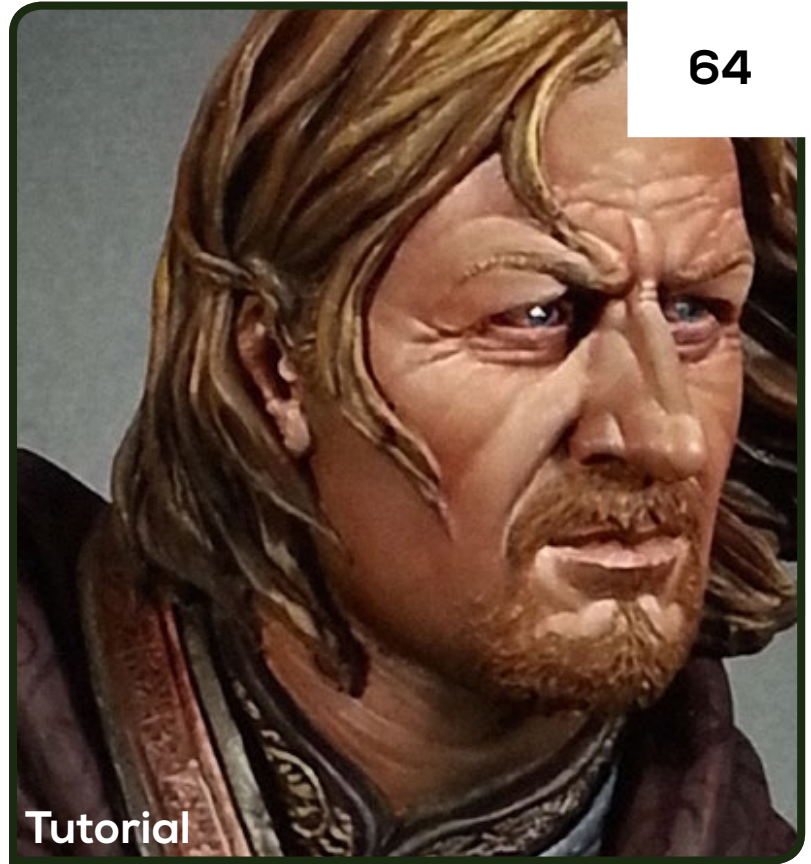

# HIGHLIGHTS



**Questions?  
Page 90**

# CONTENTS

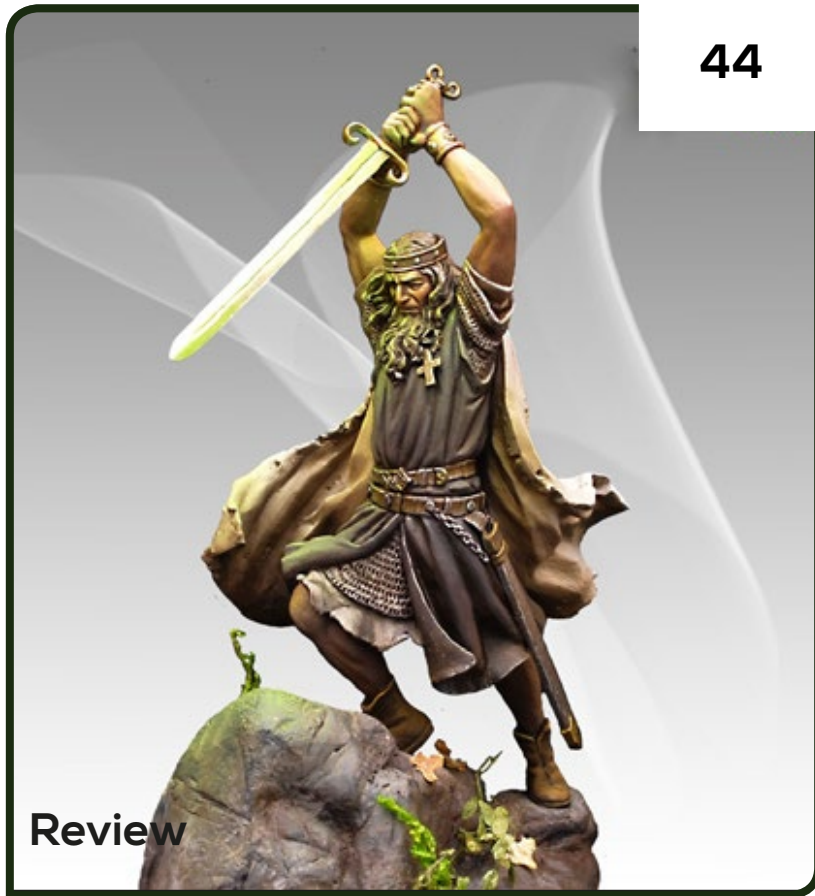

**44**

**Review**



**84**

**Tutorial**

<b>6</b>	Headlines	The latest news from the hobby
<b>8</b>	Gamespace	Regular game review
<b>12</b>	Insight	Insider interviews
<b>22</b>	Inspiration	Colour Inspiration
<b>25</b>	Show Report	October Roundup
<b>28</b>	Review	Robert Chaudon's Diablito
<b>30</b>	Tutorial	Malifaux gaming table Part 8
<b>40</b>	Show Report	LUDICA 2013
<b>44</b>	Review	Nocturna's Uther Pendragon
<b>46</b>	Exposé	What's hot this month
<b>52</b>	Review	GW's Mirkwood Rangers
<b>54</b>	Market Place	Modelling Tools & Accessories
<b>60</b>	Putty&Paint	Putty & Paint Collaboration
<b>64</b>	Tutorial	Boromir Bust
<b>78</b>	Review	DWC's Judge Anderson
<b>80</b>	Show Report	Agram Arena Winter 2013
<b>84</b>	Tutorial	Sculpting Part 2
<b>90</b>	Questions?	With Jean Bey
<b>97</b>	Exhibition	Reader image submissions

## Pocket Money Wargames

*Affordable quality*

Pocket Money Wargames is a business venture created by Dave Hutchby. Dave Hutchby has been playing 'toy soldiers' since the 1970s. In the 30 years he has been playing, he has been World Wargames Champion twice and for 15 years helped to organise the World Team Championships. Dave is also a founding member of both the International Wargames Federation and British Historical Games Society.

Pocket Money Wargames is Dave's second business venture and is being developed on the back of his successful figure painting business, Feronia Figure Painting. The concept driving the new venture is to produce affordable hard plastic toy soldiers. He has already sourced the designer, artist, graphic designer and production facility and is seeking funding through Indiegogo.com to push this forward. The initial range to be produced in this medium are 15mm North European High Medieval, consisting of English longbowmen, medieval pikemen and spearmen, halberdiers, crossbowmen, handgunners and mounted crossbowmen and a selection of mounted and dismounted knights.

Dave wants to make an affordable army and wants to turn buying 'toy soldiers' back into a pocket money hobby.

Dave will only be able to do this if people are willing to contribute towards his business venture. When people fund him, there are a number of perks available to them depending on how much they want to contribute. The contributions starts at £10 and ranges up to £1,000 but people can contribute any amount without taking advantage of the perks.

Facebook

<https://www.facebook.com/PocketMoneyWargames>

Twitter

[www.twitter.com/pocketmoneywar](http://www.twitter.com/pocketmoneywar)

Blog

<http://pocketmoneywargames.wordpress.com/>

Indiegogo

<http://www.indiegogo.com/projects/pocket-money-15mm-wargames-figures>

Feronia Figure Painting

[www.feroniafigurepainting.co.uk](http://www.feroniafigurepainting.co.uk)

Pocket Money Wargames is part of Feronia Figure Painting.



## Fantasy Flight Games



The Uthuk Y'llan hordes march out of the Ru Darklands into the realm of Terrinoth, spreading terror and death in their wake. Only one garrison of the Daqan Lords stands in the way of the coming onslaught. The bloodthirsty ferocity of the Uthuk Y'llan may be the ultimate test of the Daqan Lords' cunning and military intelligence. As the invasion begins, you can finally put your own skills as a general to the test, because BattleLore Second Edition is now available at your local retailer! For more information click [here](#).



## Woodland Scenics

Woodland Scenics have created a material for making terrain quickly and easily. It's called Shaper Sheet and comes in two sizes. Use this unique material to model all types of terrain. The strong, pliable sheet can be shaped and reshaped to create any level of detail and it holds its form without any understructure. This material is formulated to mechanically bond with the new Shaper Sheet Plaster to create a thin, hard shell ready for landscaping. Ideal for layouts, dioramas, displays and arts & crafts. More information can be found [here](#).



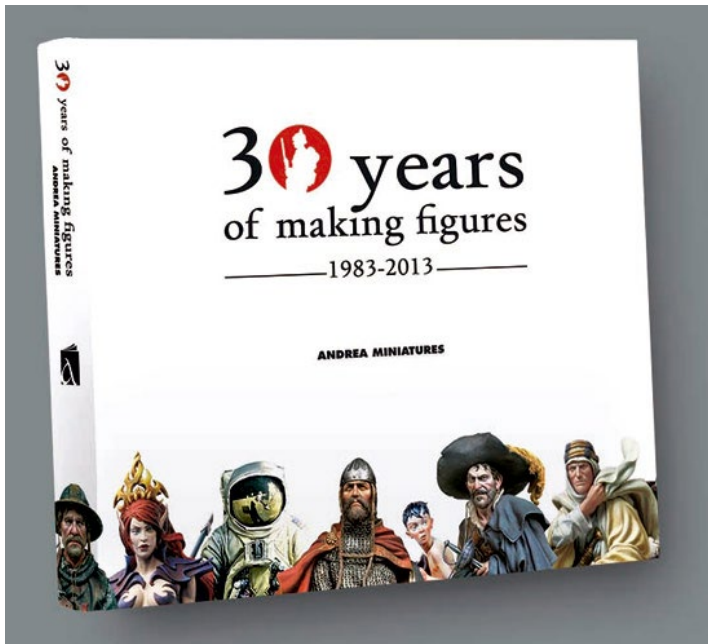

# ANDREA Miniatures

Celebrating 30 years of making miniatures and models, Andrea Miniatures have released a book to help fans celebrate with them. The colossal hard cover book, measuring 300mm x 300mm has 360 pages and contains images of over 860 miniatures and information about collection Andrea miniatures from throughout their 30 year history.

The book will be limited edition print run with only 350 copies available and printed in English. To go with it's massive size is a massive price tag of 110 Euro's.

For more information visit their website [here](#).



There is no new paint set from Scale75 this month...but, they're releasing something much bigger. The Scalecolor Collection. This paint set contains 63 colours that are airbrush ready and have a super matt finish and they also come in a handy aluminium tray for easy transportation. The set retails for 165.29 € Plus P&P which works out roughly as £2.20 a bottle and a free tray. Now all we have to do is hope the Royal Mail don't realise what it is when it's posted.

For more details visit their website [here](#).

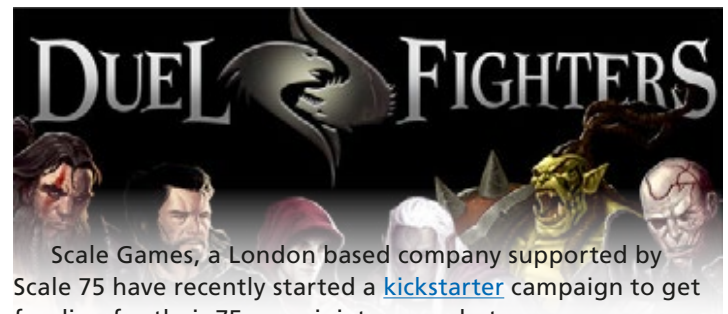

Scale Games, a London based company supported by Scale 75 have recently started a [kickstarter](#) campaign to get funding for their 75mm miniature combat game.

According to Scale Games, in contrast to other war games, where you might field dozens or even hundreds of figures, in [Duel Fighters](#) the manageable scale and the reduced number of miniatures allows players to choose from a much greater range of options and actions, providing you with a range and depth of combat that you would usually only find in typical classic fantasy medieval RPGs.

Scale Games wanted to create and reflect in this game all the dynamism of movement, skill and dirty tricks that we have all seen in our favourite movies, right down to those epic "This is the end for you" dialogues that all archenemies deliver when the hero is facing his doom and that very often end with yet another defeated villain.



# DREADBALL™

By Jake Cannon



Most of you will be familiar with Dreadball at this point. Many people I speak to are aware of it, but when I ask a question that I always expect to know the answer to – so, you've seen it around, I assume you've played it. What do you think of it?



## Intro

I decided to write this review because of the amount of people that were replying with a “no” to having tried it. To me, Dreadball is very much like Star Wars X-Wing, don't listen to the hype just find someone with a copy and get a game in. Love it or hate it I guarantee it will surprise you on some level and if you are anything like me, then you'll be hooked.

So, for our previously mentioned readers that live in a cave with internet so they can download this magazine, yet have somehow not heard about Dreadball, here is a quick summary.

Dreadball is a sci-fi sports game that aims to provide two people with a fun and fast paced experience. It is made and distributed by Mantic Games and owes so much of its success to the Kickstarter method of advertising and revenue generation. Indeed, this is one of the big Kickstarter contenders





and has achieved massive success through that medium. So, what else do you need to know? It's not a million miles away from Blood Bowl and later I will be draw a couple of comparisons for those hard core Blood Bowl fans amongst you. Without further delay, let's dive into the game play.

## Gameplay

The basic principle of this game is to score points. You can do this by throwing the ball (or sometimes balls) into one of your opponent's score zones. The further into the score zone, the more points it is worth. You also have some bonus hexes to shoot from where the shots are harder, but are also worth an extra point as well as the chance to showboat and showboating is so worth the risk.

Mechanically, this game is really tight which is something that really drew me to this game. Long story short, all checks start off on 3d6. Penalty and advantage modifiers to checks add or remove dice, but the target number to succeed on a roll is based on the associated statistic of the activating model. As an example, the simplest advantage to a check is whether or not the performing player is trained to perform that certain action; strikers get bonuses to throwing and catching, guards get bonuses to smashing and resisting getting smashed etc. This leads to really fast game play as sorting out a check is as simple as 3 dice base, plus one for training, minus one due to trying to do it in an enemy threat zone so, three dice with a five on any of them being a suc-

cess. That's all the calculations needed. Roll the dice, find the result and keep playing.

Another nice aspect of the dice check mechanic is doubling up. This occurs if a player gets double the number of successes needed which allows the model to take a bonus action or other rewards. This means static tests where one success is needed are handled the same way as opposed checks where you work out who won and if they doubled up the losers number of successes. I don't mean to gush here, but anyone who reads my reviews knows I am a real fan of the mechanics of a game so, what I say next shouldn't be a surprise — the core mechanic of this game is superb. It is so simple and resilient that it can handle everything you want to do in a game of this scale. I don't see it working on a tabletop level, but here, it makes this game work and keeps it flowing. OK, less gushing now — what else is present?

The score style of this game is also well worth mentioning here. Dreadball utilises a sliding score system where if one person scores then they move the slider the value of the score toward their end of the board. If one player gets their score marker to 7 points, then they win, bearing in mind the highest single score possible in one score is 4 points. This means you always have at least a turn to reply and drag your opponent back on the score track.

Now I have discussed the mechanic of how the game works here, but I think you should also have an insight into

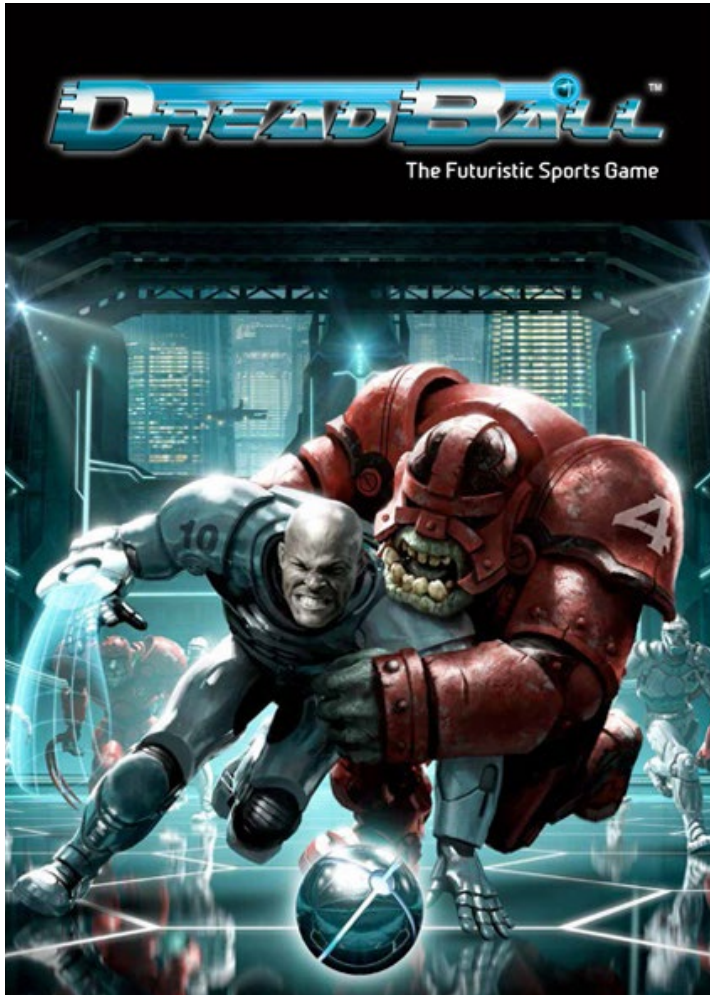

variety of teams now on the market, it means you can have a wide variety of play options and each team can be customised and played to each coach's preferences.

### Components

Right, deep breath. Mantic have done an...admirable...an acceptable...well, they have done a job here. If you are looking at the models objectively (cost wise), £15 for a team of 8-10 miniatures is a great price for getting people into the hobby and the game, but as far as quality miniatures go, these are lacking that little something...and that medium something...and that large something. Why am I so harsh on these mini's? Let's start with the basics — mould lines. They are pretty bad here. Next, the joins; I have built dozens of these models and I could open a real estate operation selling off the amount of space left between the arms and bodies of these models. Seriously the teams should come with a free pot of liquid green stuff. OK, rant over.

Objectively speaking, these models are fine and serve their purpose well. Some of the teams have different types of players that look a little too similar, but with a good paint job that issue is all sorted out. If you are looking for a challenging painting project, don't dismiss these models too quickly; with some cleaning up and a little love and hard work you can create a truly unique and personal team that will drop jaws.

Away from the models the components are good; the board and cards are good quality and the only component that really isn't up to scratch is the cardboard tokens, which you can buy an acrylic upgrade kit and I must say it is well worth it.

how the games flow. With 5 actions you have lots of choices of what to do, but setting things up in the right order is paramount to achieving success. Spilling the ball will end your entire turn so, you need to make sure you use non-ball carriers first and set up for your passing and shooting afterwards. Different teams have different strengths; do you take a pass and shoot team or a bruiser team? With the wide





ations where you will concede a goal in return for favourable position on the reset. This keeps the game flowing and leads to, in my opinion, more strategic gameplay as opposed to rehearsed plays and execution.

Now I have one thing which I really want to mention here as I am so grateful to Dreadball for doing and it relates to the Orx. If I were to ask most Games Workshop players if they are scared of Orks, or Orcs on the battlefield they would probably laugh at me and at best they might say “yes, but only in large numbers”. Now, in Dreadball, I rocked up with some humans for my first ever game and faced off against some Orx.

Finally, the rule-book is clearly laid out with good examples. It is full colour and most importantly, each book after the original comes with an up to date errata and FAQ which includes questions asked on the Dreadball forums and at tournaments as well as commentary from the Dreadball creator as to why certain errata and rulings have come about. Doesn't sound like much, but the support for this game is awesome.

I wasn't scared. I play games, how scary can the Orx be? I'm sure they will hit hard and not give up the ball easily, but I'm sure they can't be that bad — turns out I was wrong. Two of my players were killed during my opponent's first turn and two of my other players were off injured. Orx are scary. Really scary. They will be respected, either the easy way or the hard way. This is something I love about Dreadball, they have made Orx scary again. Thank you Dreadball, THANK YOU.

## Summary

I said earlier I would run a few comparisons between Dreadball and Blood Bowl and here they are — I find that Dreadball really does answer the problems I have with Blood Bowl. My first issue with Blood Bowl is the game length; it takes ages. Even if you both know how to play, it is a very stop/start experience that whilst enjoyable, is not something I would suggest playing in a short evening of gaming. It's something I would have to put time aside for to make sure the game didn't get cut short. Dreadball, on the other hand, takes about an hour and the down time during a game is negligible. There is always your next move to plan and execute.

The second comparison I will draw is that in Blood Bowl, I readily find it's all about set plays. You are on offence and you set up as such. Someone scores; you set back up on defence. I find it is very meta game-y. Dreadball doesn't stop. If someone scores, the turn ends and the ball shoots back out. No need to set up again; every player stays where they are and play continues. This can lead to situ-

So what do I think of Dreadball? I really enjoy this game. I find that every game is different and the “underdog” rules really work for getting a brand new team up to a level to be able to compete with a veteran team. I would highly recommend getting a game of this if you can and prepare to be impressed. If you are lucky enough to have a store running a league, get in quick and get curb stomping.



# INSIGHT

interview with **Rafael García Marín**



**Place of Origin?**  
Madrid, Spain.

**Years Painting?**

Started painting at age 12, but serious contest/pro painting since 2006. So as of today, 7 years.

**Major Awards?**

My biggest award is no medal or statue, it's all the people that read my blog, follow my work and all the friends I made in the community. :)

**Future Plans?**

Ideally, quit my job and just spend my time around minis. Even if this does not happen, complete a High Elf army to Golden Demon winner level.

If there was a prize for the busiest painter, this guy must surely get the award. Display painter, army painter, sculptor, prolific blogger, competition judge and tutor are just a few of the many caps he wears. This is Rafael Garcia Marin, aka Volomir!

This is the High Elf Dragonlord which I started converting in 2010. Working on it went on and off until I finally decided to finish it in 2013. This has been the piece that has roamed my workbench the longest, so finishing it brought me a lot of peace. He will be one of the most important pieces in my High Elf army.

The Dragonlord went to Golden Demon Germany 2013 and won Gold in the Fantasy Monster category, the one where competition was probably the hardest.



**Q1:** *This year, you have attended numerous Games Days and more recently Monte San Savino. You also attend lots of painting course weekends and also took part in the first Painting Buddha DVD. What has been the highlight of 2013 for you and why?*

**A1:** This year has been my greatest year painting wise. I can't really say which is the highlight of the year because so many great things happened. To the list you mentioned, I would add the wonderful experiences of being judge in the Painting Crusade in Belgium, participating in the Spring Angel in Russia or my participation in the MuMi initiative (the future Museum of Miniatures in Milan). My blog turned 5 years old! I can just hope for a 2014 at least as good as this one!

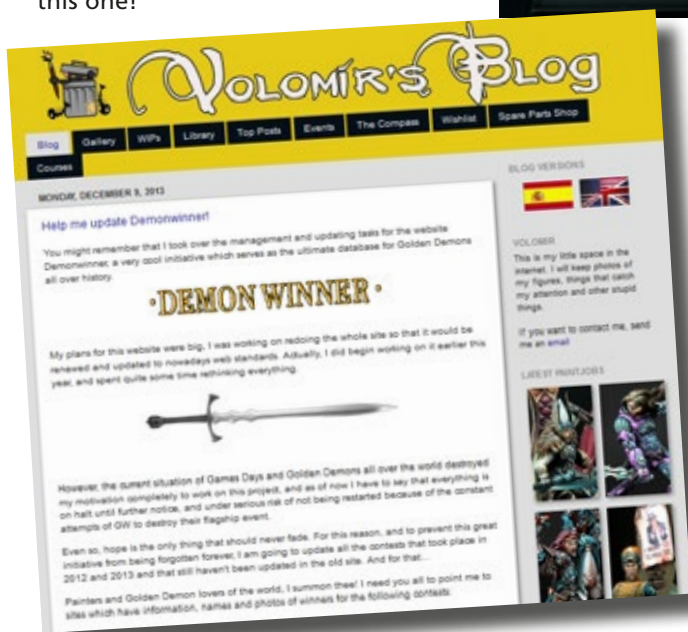

**Q2:** *I, like many others, am an avid reader of your blog; blogging and social media are becoming a very important part of being a successful painter; do you enjoy this aspect of the hobby or do you think it's just a necessity?*

**A2:** For me, it's probably what I most enjoy with painting and modelling. It's not a necessity for me as I currently don't make a living on my painting. I simply love blogging, contributing to the community, reporting from events... I am endlessly passionate about this because I think that painting miniatures is the fuel for a huge community of great people. I receive a lot of love and good things from them so I try to give back as much as I can by writing on my blog: articles, tutorials, interviews, you name it! There's nothing better than receiving an email from someone that loves what you are doing and thanks you for it, or just running into strangers that know you and want to talk to you because they follow what you are doing. Priceless!



**Q3:** *To most, miniature painting is a hobby but to some it's actually a full time job. Do you consider it work and if so, what do you do to get away from painting?*

**A3:** This is a great question because I am always struggling with this topic. Painting as a full time job is very hard; it's very badly paid and it's hugely frustrating, especially in Spain with our nasty regulations for freelancing. I would not recommend anyone to try to make a living out of it unless they are crazy and don't mind living under a bridge. It is true that I sometimes make money from this, mainly from courses and a few commissions, but normally I just paint for myself and my main objective is to raise awareness and dignity for our artistic activity. Buyers expect very good painting jobs for very little money and this is not good for anyone.

**Q4:** *You do a lot of painting courses, how much work goes into planning a course?*

**A4:** There is a lot of planning behind this. I started out imitating other painting courses I went to when I started, but with experience you get feedback from attendees and you see what they really need or look for. My courses always end up with a little survey which I use to improve them in the future. They are constantly evolving to something better (I believe). Right now, I think I have developed a framework for painting courses which is working very well in Spain, but I also do workshops outside my country. These are way more difficult to organize because of travelling, but are also very interesting. I also get to travel which is something I love!

**Q5:** *When did you first discover the hobby and what drew you to it?*

**A5:** I started out playing Warhammer as a kid, but I drifted from the game to the painting aspect because what I loved the most was the sight of wonderfully painted armies on the battlefield. I am always









debating whether to paint armies or paint showcase miniatures, so I'm currently trying to find a place in between by developing an army to a contest winner showcase level. I am not doing bad so far, but I hope to live long enough to finish it!

**Q6:** *Many people have a seminal miniature where, during the painting, things click, techniques slot into place and everything just goes right, what was yours?*

**A6:** I think that was my Nob Ork from 2008. I had the huge fortune to be able to paint it with direct supervision of my former master Alfonso Giraldes and he was a huge help, especially when I said "this is finished" but he could find thousands of little details that I could work on to improve it. He made a list of those and I followed it through and by doing that I could learn what I was doing wrong with contrast and definition. I think that those are now the main pillars of my painting.

**Q7:** *A number of your miniatures have a lot of work involved; not only the painting, but the conversion work as well. How do you keep motivated while completing these lengthy projects?*

**A7:** I think that is where I find the most strength from is my blog. Sharing progress with everyone is a huge help, for guidance and for courage. My biggest project so far was the Last Stand of the Crimson Fists, which I kept in the dark during the whole process; the diary I wrote on how I did it during those eight months shows how my motivation crumbled from time to time. If I had shared it and received comments and good wishes from my friends in the blog, I would have probably had a better time making it. Take the Dragon for example, a project that was on/off many times: if it hadn't been for all those encouraging messages that demanded more progress, I don't know if I would have finished it.

**Q8:** *One of the things I like about your painting style is the richness of colours and strong contrast you get into a miniature. In your opinion, what do you like best about your own miniatures?*

**A8:** Well, you just said it! ☺ The thing I appreciate the most is contrast and I think that is pretty obvious when looking at my miniatures. I normally try to look for vibrant and saturated colours, avoiding overall grey



and brown colour schemes which are way more realistic, but also boring in my opinion. In my understanding of miniature painting, light is essential, so my paintjobs are usually centred around big contrasted light effects, sometimes a bit too dramatic and exaggerated, but they make a huge difference to me. Soft blending is also important of course, but it's not my main trait, or at least it's not what I'm looking for.

**Q9:** *One of my favourite miniatures you have done is your version of Malus Darkblade and I think this is because that you sculpted the miniature and then went on to paint it. Have you considered or ever been approached to sculpt more miniatures?*

**A9:** Yes, actually last year I finished my first scratch-built 54mm miniature. I tried this in the past but I never completed one from beginning to end and it was a great experience and very satisfaction. It's a 54mm Kasrkin Sergeant based on the concept art by Karl Kopinski. There will be good photos on my blog very soon! I am going to keep on modelling and painting my own figures, because for me the best miniature artist is the one that sculpts and paints, capable of mastering the whole creation process from concept to paintjob.

**Q10** : *Lastly, what are you working on at the moment?*

**A10** : Lots of things on my table always! At this very moment, I am fulfilling the most intimate desire of a friend who is going to propose to her boyfriend by using three miniatures painted by me (Infinity mercs, his greatest passion). A short and simple, but life changing project which I can't wait to tell you guys all about! It's still a secret so I hope he doesn't read this interview before she proposes... I'm sure they will laugh a lot when they read this after she does! Apart from that I am continuing my work on the High Elf army, some Ellyrian Reavers which you can see now in process in the blog. Those are not the only things on the table; there's a diorama based around the Hobbit and a 75mm scene on Star Wars... damn, I need three lives! ©



# THE DRAGON LORD



Also available  
The Old Gnome &  
The Gem Smith  
plus many more

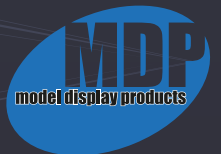

Coming April 2014

# ARCWORLD





By Lyn Stahl

[www.metalheadminis.com](http://www.metalheadminis.com)
[www.facebook.com/lynstahlartist](https://www.facebook.com/lynstahlartist)
[Twitter- @Metalhead\\_Minis](https://twitter.com/Metalhead_Minis)

# finding INSPIRATION for painting miniatures & models

Lyn Stahl was introduced to miniature painting by a close friend in 1997. What started out as just a fun and relaxing hobby eventually turned into the company Metalhead Minis- Miniature Painting, Consignment and Sales in July of 2009. It has been a fun-filled roller coaster full of painting competitions and teaching miniature painting at conventions such as GenCon, GenghisCon and Texicon. Lyn is always happy to be a part of charities and/or any event where she can share her love for the hobby to people of all ages.

Over the years, many people have asked me questions such as "What do you do if you are stuck on what colour you want to paint (insert part of miniature/model here)?", "I have not painted in a while; what is your advice for getting back into painting?" and "How do artists come up with ideas for basing and creating the scene?". The objective of this article is to answer these questions for others who might have the same questions.

Every now and then, all artists have been at a point where they were either stuck on one colour or the whole colour scheme for a particular miniature/model. There are no exceptions to this. However, there are many resources that one can use in order to obtain ideas. Examples include online art galleries such as Cool Mini Or Not, Putty&Paint and the Reaper Miniatures Inspiration Gallery, hobby magazines, watching movies related to the theme that you want to work on, comic books, art books, textbooks, instructional DVD's, or just taking a walk outside. While these are avenues most commonly explored, I discovered while discussing this topic with others that there were a few other avenues that some of my fellow hobbyists may have either not thought of or known about.

Every now and then, all artists have been at a point where they were either stuck on one colour or the whole colour scheme.

While I have been painting professionally and competing for some years now, I have found that it is important to have some extra inspiration resources in my arsenal. For those who do the same or even just want to continue developing on their hobby skills, it definitely couldn't hurt to add these resources in as well. It has saved my sanity on many occasions to use these tools if all else failed. The following are other resources that I use:

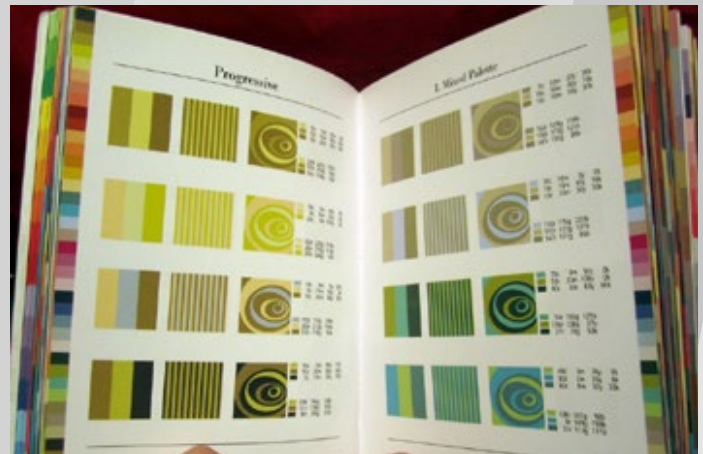
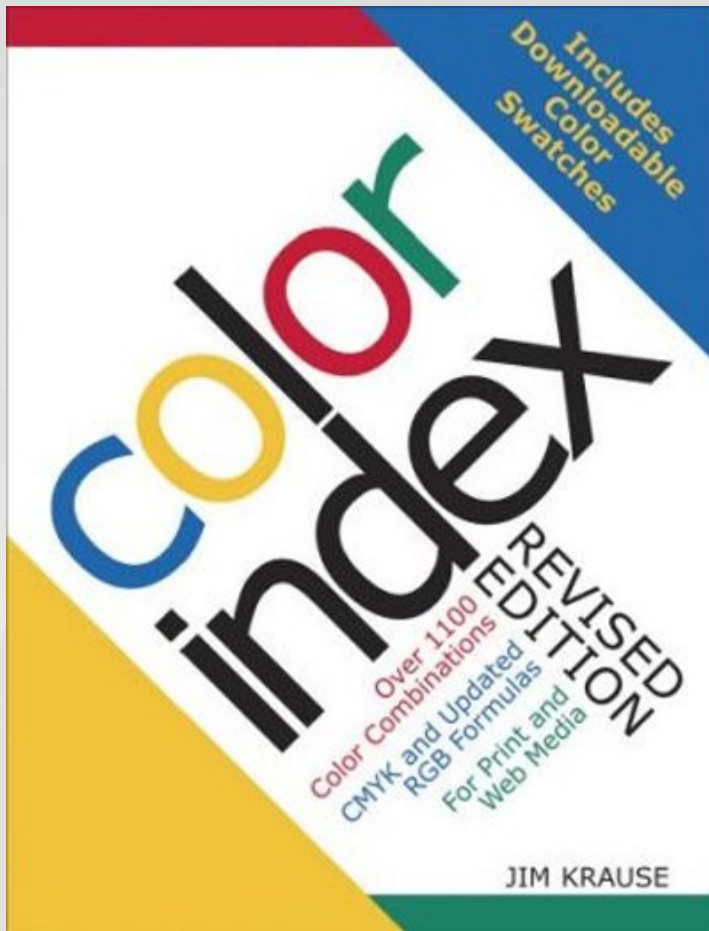

The Colour Index by Jim Krause — This book can be purchased from Amazon and it is pretty inexpensive. I give credit to the great artist Jennifer Haley for the idea of purchasing this book. She discusses the use of this book for finding colour inspiration in her instructional DVD “Miniature Painting Secrets with Jennifer Haley”. It truly is a great reference for putting colour schemes together. As shown in the picture, there are multiple examples of colours that are matched together. The book is very easy to use and has the colour index on the side for the reader to easily go through and see what colours complement the main colour they have chosen.

Game Trading Cards — Haven’t had time to play Magic the Gathering™, World of Warcraft TCG, or have those D&D cards sitting on your shelf collecting dust? Well, I have great news! Trading cards can be used for art inspiration as well. There are so many talented artists and photographers that have created amazing images on those cards. Why throw them away? I have trading cards in either their original boxes (to keep them in mint condition) or in binders and have them all sorted in such a way for quick and easy access. One idea for quick and easy access is sorting the cards by category and subcategory. For example:

Category- Human

Subcategory- Man, Woman, Dwarf, Gnome.

OR

Category- Magic User

Subcategory- Warlock, Mage, Necromancer, Wizard.

As with the other more common inspiration sources, not only are trading cards great for ideas for colours and themes, but also for basing. For example, when looking at the picture

with the Magic cards, there are the “swamp” mana cards. When looking at the swamp cards, notice that each one looks different. Perhaps the look of one of the swamps suits a scene for an Orc or Goblin miniature that is being painted? There is one picture of a swamp with bright colours (yellows and oranges) that would complement the green skin tone well.





For pictures of fantasy women and dragons, I love Larry Elmore's art books and art cards. His artwork is amazing and always has an epic story to tell.

For those who have children, story books are great for finding inspiration as well. So even when the time comes that those lovely children grow up, you might not want to be so quick to add those books to the yard sale pile.



"The Cool Mini Or Not Annual" (2008, 2009, 2010, 2011) - Granted these are considered art books, but the reason that I mention them is because there are a lot of people who do not know of their existence. They are \$35 each through [coolminiornot.com](http://coolminiornot.com) and trust me, they are worth the money. They are very well put together and the pictures are beautiful. Of course their art gallery can be accessed online, but I am a little old fashioned and still like to own the physical book. One other benefit is that the books are divided into categories such as fantasy, diorama and sci-fi for easy reference. I get excited like a little kid on Christmas when the new books are released.

I am happy to have shared these ideas and hope that these resources will be helpful to you as well. Please feel free to get in touch with me if you have any questions or need help with ideas.

Happy painting to all!





# A Brief Look Around the UK Shows November 2013

November is a bit of a strange month for shows in that it is the last month in the UK show circuit; OK, there are one or two very small shows in December but these are more of a club get together such as the White Rose Christmas Bash. In general, though, for most people November is the final shows for the year.

So November saw three shows, the first and probably the largest of any of the UK shows was the IPMS Nationals held at the Telford International Centre on the 9th & 10th November; this is a two day event utilising the whole of the International Centre and a lot of people will save up all year just to go to this show. To give you an idea of the size of the show, there are around 170 traders and 200 clubs displaying. Traders and clubs come from all over the world and space at the show is usually fully booked eight months before the show date.

As well as the clubs and traders there are static displays. This year there was two helicopters, a spitfire, several tanks and a simulator to entertain people and this year had a special Doctor Who area. The centre itself has everything a show could ask for from several bars and cafe/restaurant areas, a cash machine and two hotels on the grounds with several others close by so most people's needs are catered for.

This year was the fiftieth year for the UK IPMS, so was a special event in itself, doors opened early for IPMS members on both days and IPMS members were allowed in for free if they produced their membership cards; otherwise entry

was about £10 per person per day and slightly cheaper if you purchased a two day ticket. Besides all the clubs, traders and static displays, there was also a huge Kit Swap area and a competition. The competition was run for the IPMS members only though which meant if you were not a member of the IPMS, then you could not enter the competition. I think this is limited the competition a bit and it did show in some of the categories, but at the end of the day, it was their show and their rules, a little like Golden Demon I guess.

There was only a short window for members to get their entries into the competition as it closed for judging at 12pm on the Saturday, but it re-opened for viewing for members and visitors from around 3pm on the Saturday and all day on the Sunday. As the show is always on the weekend of the November Ceremonies, a 3 minute silence was observed at 11am on the Sunday; this is usually preceded by the "Last Post" and a reading with "Reveille" although I do get frustrated when everybody claps after this! Maybe it is just my military background, but to me it is supposed to be a solemn moment after remembrance.



By **Martyn Dorey**



Like a lot of the larger UK shows, the IPMS nationals is used as a launch platform for latest releases by traders and manufacturers alike; some of the larger companies attending, but were not really figure companies included Zoukei-Mura Inc from Japan, Revell, Airfix and many other companies that you wouldn't necessarily see at the normal shows. Figure traders do attend, though, so come on lift those shoulders, smile and think about going next year because there really is something for all modellers there and if you

can't find it then that is because it probably isn't available yet or you haven't seen everything :o)

The weekend of the 16th & 17th November saw Warfare take place at the Rivermead Leisure Centre in Reading. This is a two day event and is usually very popular. I went last year as a visitor and noted it hadn't changed since a visit 10 years before. I tried to get a trade space for this year back in March/April but, was told everything was fully booked and I would be on the reserve list along with some 35 other traders...



The final show for 2013 was Bugle Call. This is a BMSS show held on Sunday 24th November at the Pavilions in Bath, so not only can you persuade the wife/girlfriend to come along, you can leave them to go shopping or treat them to a spa whilst you go to a model show—BARGAIN! ☺

Earlier this year, the Bristol Branch of the BMSS disbanded, so it was touch and go for a while as to whether the show would go ahead. Thankfully, it did and this year it didn't have to close early because of the River Avon about to burst its banks. There was plenty of figures to be seen in all scales around the hall from the clubs attending as well as armour and aircraft and nice work in the competition, but sadly once again, there was not a single entry in the juniors category.

This year saw a large amount of garage kits being displayed as both Dean Eyre and Scott Griffiths were in attendance with Scott's collection alone filling a 12ft space. Also the Wings of Fire display took up 18ft of table space overflowing with dragons of all shapes and sizes and for those able to attend it also gave them the chance to see Peter Bell's Golden Demon entry "Radagast" up close and personal and I believe it was a favourite of the judges as well.

Well that is it for the UK shows this year and it all starts again in January, so I look forward to seeing some of you next year at the shows.



By **Marta Ślusarska**

# Unboxing

## Roberto Chaudon's Diablito

Material: **Resin**  
 Scale: **60mm tall**  
 Price: **£26.60**  
 Available from:

[www.robortochaudonblog.blogspot.co.uk](http://www.robortochaudonblog.blogspot.co.uk)

or

[www.elgrecominiatures.co.uk](http://www.elgrecominiatures.co.uk)



Today I'd like to present you with yet another curious miniature in my collection. This piece, done by one of my favourite sculptors Roberto Chaudon, is called 'Diablito', which most likely means little devil or imp maybe. Like with many of my hobby purchases, I knew from the very first moment I saw a WIP photo of the sculpt that I was going buy it.

For some reason, after seeing photos of the green I expected the miniature to be in a small scale. To my surprise and joy, when I found it on the El Greco stand during Euro-militarie, it turned out to be much bigger. It is 60mm tall, but I guess the character it represents is somehow distorted, so I'd say the scale is bigger than 1:35.

### The Packaging

It arrived in just a simple bag, with a photo of the miniature in the front. Yet again I'm not too happy about that, but the parts are thick enough so the miniature didn't suffer any damage in transport. If I recall correctly, The Grinder, (another of Roberto's lovely sculpts), a massive bust of a barbarian warrior, came packed the same way; I guess that's the standard way of packing his miniatures. Maybe I'm exaggerating my expectations, wishing that every company to





packed their miniatures like Pegaso or Andrea. After, all resin parts aren't that heavy and won't get damaged so easily when touching/hitting each other in transport.

### Quality of the Cast

The cast itself is really good, shifting towards excellent in most areas. There are some mould lines, of course. The worst one is on the left side of the front (you should be able to see it on the photo from the front) and there are some flakes of resin around, but that's rather normal. What makes it excellent are the details of the face and the textures. Every part of the miniature is covered in some sort of delicate, yet precise texture. The torso and arms are all wrinkly and look like they belong to an old man. Each legs looks like they belong to aq different animal. Even the walking stick is made of 'screaming souls'. I must admit, I rarely see this level of detailing on a miniature in such scale.

### Assembly

It seems to be pretty easy and straightforward. Diablito's tail and fig leaf fit perfectly. The arm with the walking stick needs some work though. The hole inside the torso is not large enough to fit the arm as it is, so some careful removing will be required.

### Overall Opinion

As you have probably guessed, I'm absolutely charmed by this miniature.

The thing that I find the most compelling about it is the face. The whole figure is rather comical and interesting, but the face makes the whole difference. It is so full of character and won't let me treat the evilness of the miniature seriously



for some reason and the cast is good enough not to spoil the concept by the execution. So if you, like me, have a thing for the weird or unusual miniatures, this one might be a great addition to your collection.

# MALIFAUX

By Marko Paunovic

## A story of a gaming board



So, what's to come? After the last article, I must admit I was in

a conundrum whether to finish the first module up to the painting stage and write this article about texturing and detailing or whether to take another module and build it up to the same point where I left this one off. The first idea would have the first module finished before I moved on to the next one and would therefore provide a sense of continuity.

However, since I'm writing as I'm building this board, this also provides some difficulties because I don't want to rush and force things.

The second idea, although leaving the module "unfinished", does enable me to work as time permits, probably building one or even two modules per month and then texturing all the modules in one go which makes more sense story-wise.

This, in turn, will also make all the textures throughout the modules the same which will tie in all the modules into one meaningful whole.

I finally opted for idea 2 and with that decided, I now needed to confer with Ana and Andrija which module to do next. Ana informed me that she had a lot of brickwork walls done so it was only natural that I do a module with brick walls. That meant that only McMourning's, Hamelin's, Ramos',



Random Ruins and Random Canals modules were available. However, Andrija informed me that he hadn't quite finished the doors for his sliding door systems (but would have them done by the end of this month/article) so all the modules connected to the Malifaux Masters were out of the question as well. That left the two Random modules which I decided to do in parallel.

When doing a project in a group, it is always good to communicate as frequently as possible to know where your companions are at so you can plan ahead. Also, always leave yourself a couple of options if something fails (and it will).

So what's the philosophy (and/or fluff) behind the two Random modules?

**1. Random Ruins (Random 1 from now on)**

The idea of the module is to have some sort of underground passage way that is half caved in with some fluid flowing from the pipes here and there and in the midst of the rubble to have some Soul Stones showing. The walls would be brick and the floors would be stone (one of the patterns Ana made in the [last issue](#)).



## Marko's Lamentations: Texturing – part I

As you might remember, last time we finished the building of the first module. All that is left to do before painting is to texture it. This little text

is to tell you what materials I use to texture all my terrain, dioramas and bases. The variation in size helps me achieve almost any texture I desire.



1

2a

2b

2c

3

1. Smallest grain sand that I could find – sand for chinchillas. I buy the stuff at a local pet store (which is a great source for various sized gravel and sand). This I mainly use for recreating pavement/concrete/plaster/mortar.

2. Assortment of sand and gravel from Gale Force 9 (or GF9):

a) GF9 Fine basing grit

b) GF9 Medium basing grit

c) GF9 Rocky basing grit

I find these three very useful especially mixed together as they naturally progress in size.

3. Some small gravel/pebbles (in real size) that I pick up in the local park. I use them as stones/small boulders in my miniature work. They provide the final, largest size stones. Try not to take the round gravel as it doesn't paint nicely. If you can choose, pick the ones with the sharpest edges possible.



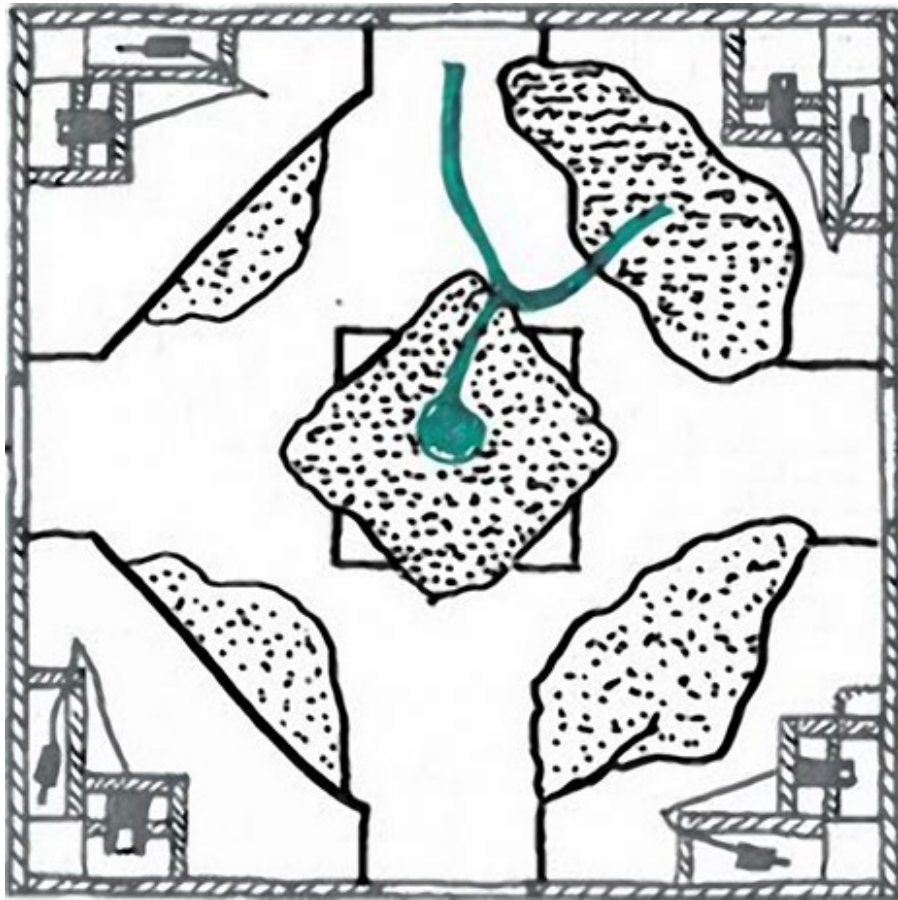

only because there is loads of scenery to be navigated around and this enables me to exchange the wire if it's too short or long much more easily. As with the module from last month's issue, these modules will have 9 LEDs and the calculation for the resistor is the same as last time as well.

For Random 1 module I decided to have four LEDs as bulkhead lights on the corridors above the four entries to the module. Four LEDs would shine the Soul Stones in the cave-ins and the final LED would be inside the tube/pipe and will illuminate the water/fluid coming out of it.

Random module 2 will have 8 LEDs serving as bulkhead lights throughout the module and one LED to illuminate the water coming from the suit tiles into the canals.

Once the wiring was done, I proceeded to place floor tile casts supplied by Ana on both modules simultaneously. Once that was done, after a bit of tailoring of the casts, I put the wall casts into place.

## 2. Random Canals (Random 2 from now on)

This module will be similar in concept to the Random 1, but will be intact, without any cave-ins. There will be a central pillar (5 x 5 cm cross-section) which will prevent Line-Of-Sight from one entry to the next. All around that pillar there will be a small canal with a canal per side going toward each entry of the module. The canals will be 10mm wide and Ana will be making the stone slabs for its construction. Also, in the middle of each side of the central pillar, there will be a stone tile with one of the suits of Malifaux (ram, tome, mask and crow) that Ana made in [FPM Issue 3](#). From each tile, there will be a stream falling into the canals. Walls and floor will be brick except for the canal and some details which will be stonework.

Enough with the chit-chat, time to get busy. First up, deciding where to place the LEDs and cutting the wires to length. Remember to always leave a few cm more just in case. You may have noticed that I use the terminal blocks to connect the LEDs to the wires instead of soldering them. I do this

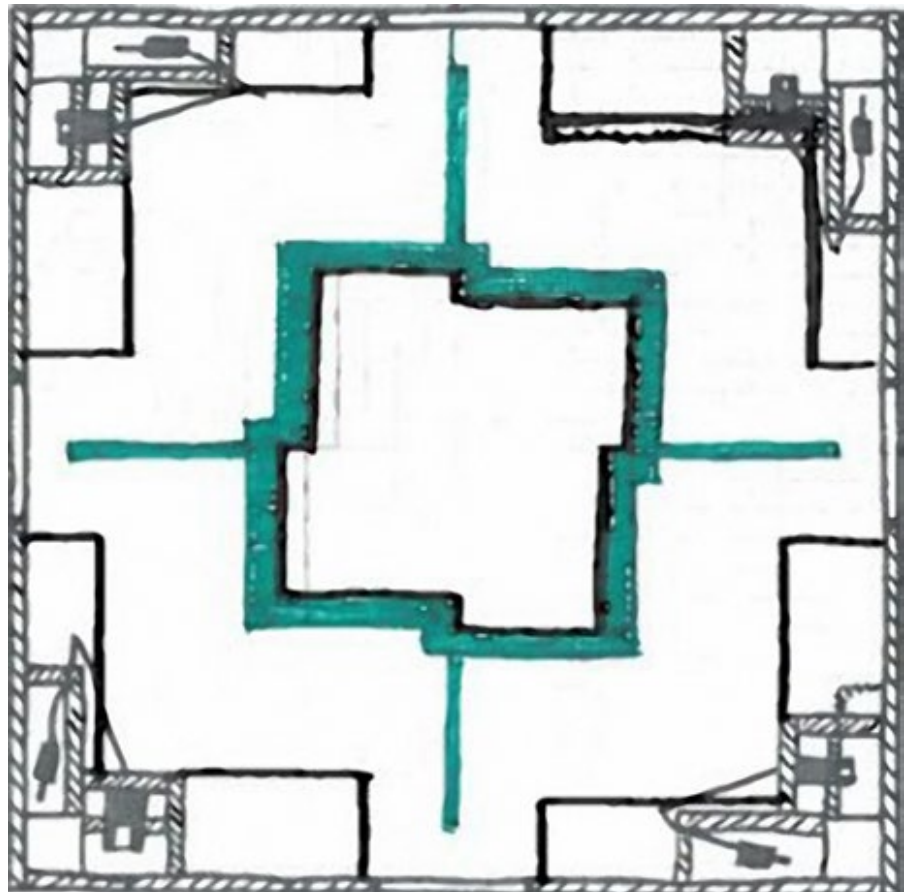





### Electronics Top Tips

After last month's issue, I've had a couple inquiries into what exactly is a multimeter. Well, according to Wikipedia, it is "A multimeter or a multimeter, also known as a VOM (Volt-Ohm meter), is an electronic measuring instrument that combines several measurement functions in one unit. A typical multimeter would include basic features such as the ability to measure voltage, current and resistance."

So basically, it's a machine that can show you the amps, volts or ohms in your circuit. It comes in two forms: Digital and Analogue.

Digital, among other features, always needs batteries to run and analogue doesn't. That's why I prefer the analog one — it'll never let you down (unless you fry it) and since I am not using it in the field or in darkness so I don't really need a nice flashy display. There's no need for the digital one. Also, without batteries, running the analogue one is cheaper in the long run.

I'd like to take a bit more space here to mention another useful device called breadboard. Again wikipedia says:

"A breadboard (or protoboard) is usually a construction base for prototyping of electronics. The term "breadboard" is commonly used to refer to a solder less breadboard (plugboard).

Because the solder less breadboard for electronics does not require soldering, it is reusable. This makes it easy to use for creating temporary prototypes and experimenting with circuit design."

So, that's basically a piece of plastic board where you can "stick" your electronic components to check how your circuit works without having to solder it together first. It's really useful when trying to figure something out or trying to perfect the output result without too much hassle.

Both of these can be purchased really cheap from eBay, usually from Chinese sellers that often have free shipping. I bought them recently together for less than 15 USD with shipping.

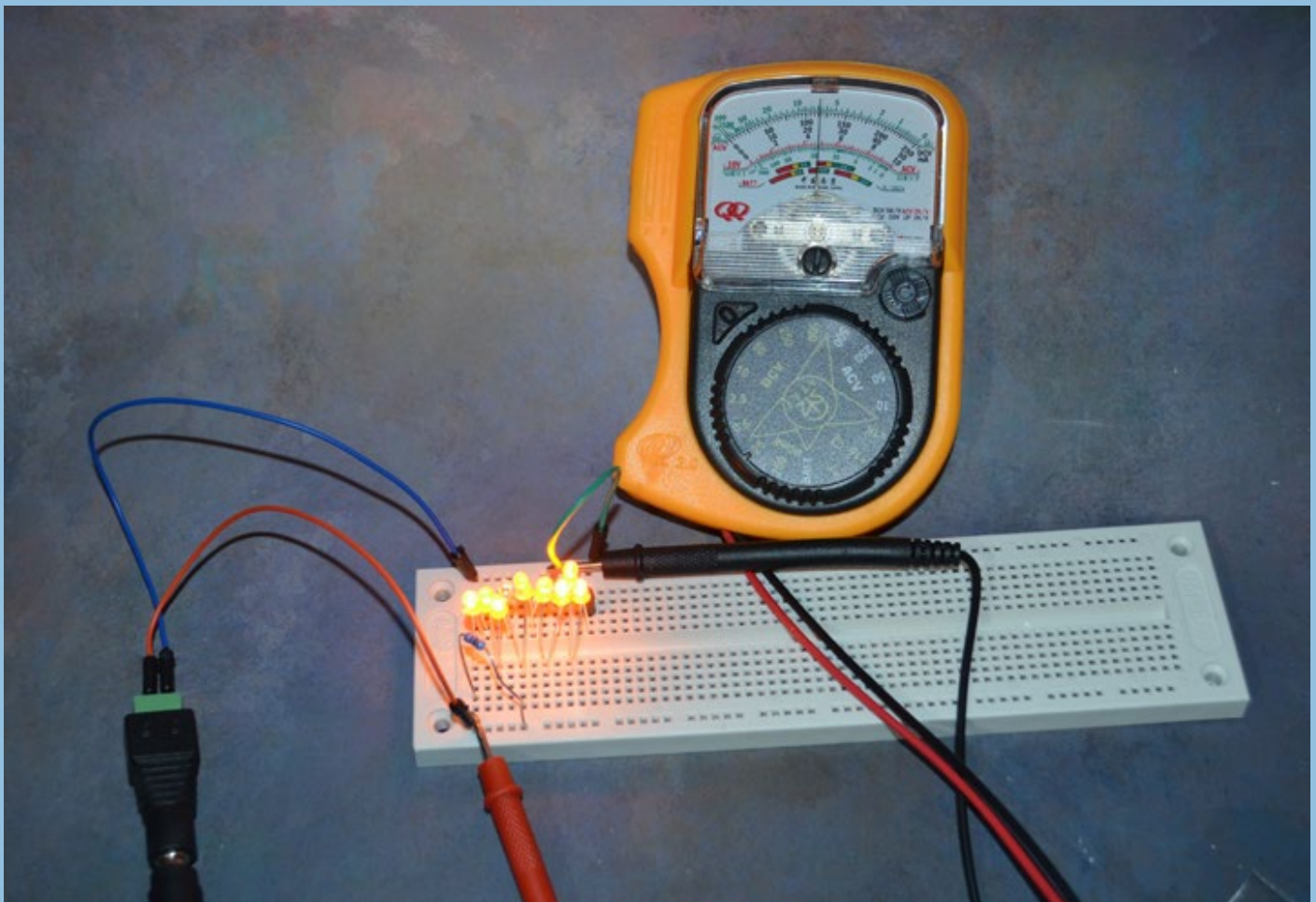



Ana's Research

Sculpting Gutter/Canal prototypes for moulding and casting

As well as casting tons of copies of all the variations of walls and floors, my task this month was to sculpt some gutters for our sewer modules. The gutters will be assembled from three kinds of 20 x 20 mm segments: a simple straight one, a 90 degrees turn for corners and a T-shaped junction.

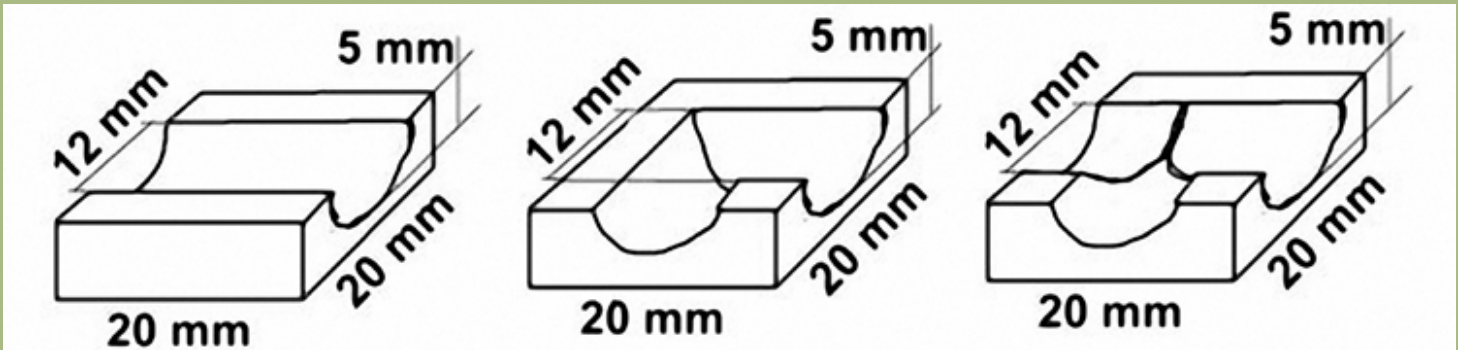

I thought the best way would be to make one long straight canal out of DAS clay and when it cures to cut then rearrange and glue the bits to get the three different desired shapes. I made a balsa frame, filled it with DAS, then pressed a plastic cylinder-shaped object into the clay to get a groove. Once that cured, I cut it up and assembled the three kinds of segments. Before proceeding to mould-making, I patched up the rough spots, filled some holes and sanded the segments.

I then glued my prototypes to a flat surface (in this case a bit of 5 mm thick balsa wood), mixed some Siligum for each tile and pressed it against my prototype. Then I let it cure for 10-15 minutes and afterwards I removed the finished moulds from my prototypes.

All that was left to do was to cast the tiles in the required numbers given to me by Marko.



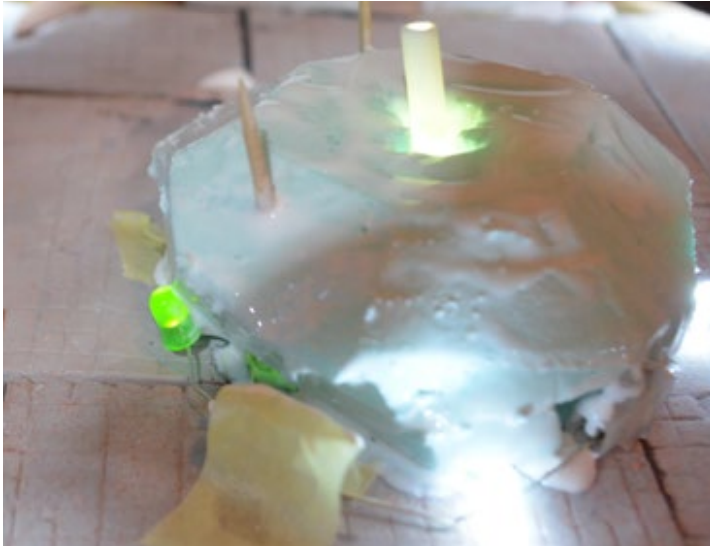

With this design of the walls, we wanted to make this build as close to building with Lego bricks as possible. We had the walls and floors standardised, easy to place and glue, yet with enough different versions to make it (almost)

impossible for the pattern to repeat itself. Furthermore, as Ana explained, once the casts were done, each of them got "personified" by some scraping and chiselling giving unique patterns without any large effort.



### Planning Top Tip

#### Sanding to size

During Ana's process of casting, it is impossible for her to make all the pieces the same thickness. With the wall sections it is not always needed, but with the floor tiles and especially for the canal tiles it is vital that they be the same thickness. That way when they are glued to the base of the module, they will all be in one level. As you might imagine, for the canal tiles it is really important because of the fluid that will flow.

In order to achieve this, I use the Proxxon Disc Sander TG-125. It is a really cool little tool that has a disc with 12cm diameter and an adjustable working table that enables me to sand it at right angle (90°) as well as any other angle. This will really come in useful for all the joints needed to be made between the various pieces Ana casts.

For the tiles I made a simple 7mm spacer out of linden slats (as in the schematics – everything below red line will get sanded). If you remember the canals should be 5mm deep. With the 7mm spacer, I'll get all the tiles to be 7mm thick which will leave 2mm of material under the bottom of canal. That in turn, will provide enough rigidity for the canal tiles and prevent them from snapping in two.

When using this machine, always wear a protective breathing mask and if possible, connect the machine to a vacuum cleaner which greatly diminishes the dust.

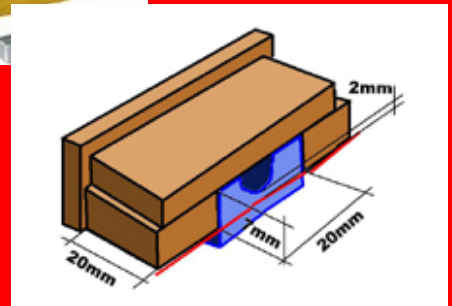

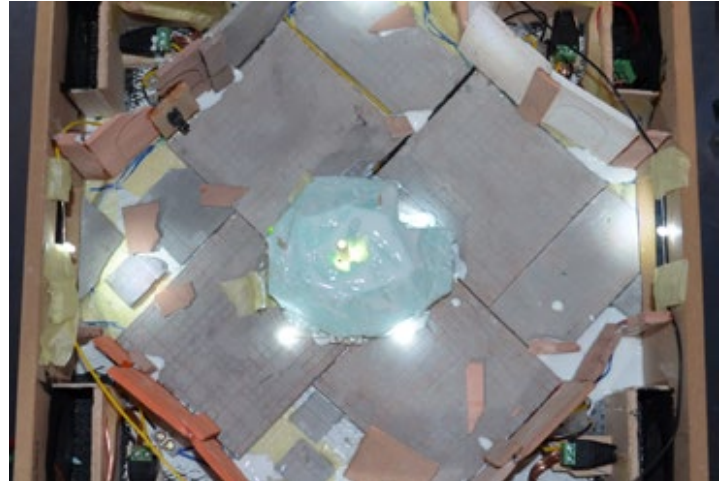

Where necessary, I made holes in the walls for the LEDs, put them inside and glued them firmly in place.

All that was remaining to do was a bit of debris, building up bumps and humps that will represent cave-ins once the texture comes and making the blue plastic foil cocoons for the Soul Stone field.



### Marko's Lamentations: Texturing – part II

ways to do them:

Eventually, when we get to the texturing part of the build of the entire board, I'll be needing a large amount of Soul Stones and there is a couple of

our needs).

1. The easiest way is to go to a hobby store and buy some clear light blue gems and glue them in place. Easy, not expensive but unfortunately you are stuck with just the one size they have (and it's usually either too small or too big for

2. The second, more difficult method is to rummage through your gravel / GF9 grit stash and find small pebbles and stones that are the appropriate size. Use Siligum (as described in Ana's Research in [FPM issue 4](#)) to make moulds and cast them in clear resin. I suggest using Vallejo Still Water one component resin. Also, you may want to try and tint the resin a bit for that extra effect.





## Andrija's Bitz and Bobz

### Cobble stone bases

With real life and my vacation stepping in this month, I didn't have too much time to dedicate to this build, so here is a small tutorial on making cobble stone bases for your round 25mm bases. It's fast and effective!

1. First take the round 25mm GW base without slots. In the pictures there is work with 6 bases so that you can relatively quickly make a lot of bases without having too many repetitive actions. On these bases that you chose for the moulds you must first smooth out the interior serial numbers and other irregularities. I worked with a variety of abrasive tools supplied with a hobby drill. Also (if you do not have a drill) these sanding bits can be individually purchased for a relatively small amount of money.
2. The next thing you need is plaster, water, sticks for mixing and a vessel in which you will make the mixture. It is best to take some kind of container that is plastic because the rest of the plaster, which is left in the pot after pouring the mixture into moulds (base) can be easily removed after the plaster sets by pressing the edges of the container so that the plaster cracks
3. In a bowl (vessel) pour the plaster and then add water. Water should be added with a small spoon for easier dosing. Feel free to add a little more water if mixture is more gel-like than liquid. It should also be noted that it pays to get special modelling plaster – the one with the smallest possible granules. It gives better, firmer and more resilient casts. It can be found at hobby shops for around 5 Euro/kg (not much when you consider how many bases can be cast with a kilo of plaster).
4. Gently stir the mixture in the bowl, before pouring into the moulds, to remove the air and any lumps from the mixture.
5. After you have poured the mixture into the moulds, remove excess plaster over the edges with a flat plastic object (I use an old triangle). Leave to dry at least 30 minutes.
6. When the plaster has dried, carefully remove it out of the mold.
7. On the casts, draw the patterns to be engraved by using a pencil. Glue the casts with PVA glue to the plastic 25mm bases. Allow it to dry and then engrave the pattern with an ice-pick or a similar sharp tool.
8. Paint the bases and optionally flock them.





With this, we conclude the 2013 part of the building of the FPM Malifaux modular board. Next year my team and I will be tackling the remaining 6 modules, doing all sorts of cool stuff with electronics while (hopefully) not setting ablaze the board, texturing it and, in the end, painting and detailing every module. As always, if you have any questions or suggestions about this build, feel free to contact us at Figure Painter Magazine ([terrain@figurepaintermagazine.co.uk](mailto:terrain@figurepaintermagazine.co.uk)) and we'll try to answer your questions. With seasonal greetings from the entire Modular Board building team!



New from Miniature Heroes



# WOODEN PLINTHS

A range of solid hardwood display plinths and bases.  
All are handmade from sustainable English timbers.

[www.miniature-heroes.co.uk](http://www.miniature-heroes.co.uk)

# AIRBRUSH TUITION

## BEGINNERS WAR GAME MODEL PAINTING WORKSHOP

TWO DAY March 8th & 9th 2014 10am - 4pm

[www.barwellbodyworks-shop.com](http://www.barwellbodyworks-shop.com)

*Minitaire*



war gaming figure artists paints







By Davide Rainone

# LUDICA 2013

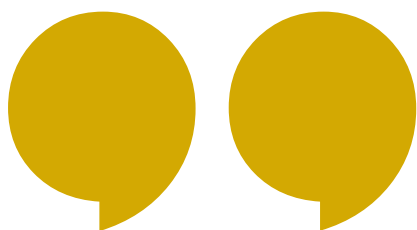

 The chance to educate a new generation to look beyond the latest phone, tablet or game console and help them to create something with their very own hands has been the greatest success for this initiative



 A few days ago, from 29th November to 1st December, the second edition of LUDICA occurred in Rome. Inside four thousand square metres of exhibition areas of Fiera di Roma there were hundreds of visitors; many had brought the whole family with lots of kids around, ready to enjoy this unique event of its kind in Italy.

LUDICA hosted stands for static and dynamic hobby modelling; there are models, wargaming, planes and cars with or without engines, railway and naval; cultural organizations and costuming like the official Star Wars Disney/Lucasfilm's 501st and Rebel Legion groups. Gotham Shadows club for Batman's DC Comics world and historical re-enactment costuming groups from Ancient Rome to the American Secession War, Vikings and the First and Second World Wars along with Softair Federation and Historical Fencing groups. There was even a stand dedicated to the ever limitless Lego and even tournaments for games like Infinity, Warhammer and historical wargaming.

The CIMS (Italian Static Model Coordination) organized all the places where regional model clubs had the chance to present their group's activities and show off their fantastic models.

Amongst them there was a special place for the second outing of the LUDICA Model Contest organised by Luca Buttafava and Andrea Nicolucci, two renowned master painters here in Italy.





The contest has different features from the usual international ones. Firstly, there is a division between Standard and Master category, but not between Fantasy and Historical. The idea behind this is that the model is the focal point and the quality of the painting regardless of the theme. The second is that the competition is completely free to enter and lastly, there is no open formula, only three awards available for both categories.

The contest Judges were Andrea "Ungugu" Grimaldi, a great Italian painter, who is a multiple Golden Demon winner and famous at the international level and Giuseppe Gensabella, another master Italian painter.

The most beautiful thing (except, of course meeting the dozens of participants and having a look at so many great models), has been to engage the children in the exhibition by the initiative of making a painting demonstration dedicated just to them.





Federico Sorgi's demo with oils

It was amazing to see so many kids leaving behind the TV and game consoles, if only for a few hours and become immersed into this new world under the careful watch of skilled painters, Alessio Bonvini and Alessio Serafini; two very kind guys who did a great job.

As well as the demos for kids, there were also demonstrations held for more experienced modellers which were free-hand painting techniques using acrylic and oil paints under the guide of the judge Grimaldi himself and the very willing Federico Sorgi (*Check out his tutorial in this issue ;)* — ed.

The Sunday evening award ceremony saw two guys triumphant; Alfonso De Negri with his "Thorunn Frozenfang" as Best of Standard and Daniele Petrucci with his "Fuciliere di Val di Noto 700" as Best of Show. The special award was a complete painting set and was won by the youngest participant to the painting contest — a five year old girl! She couldn't believe her luck thinking she had been overlooked in favour of much greater painters than herself, but was rewarded for her courage and willingness to prove herself. Her bashful happiness was welcomed by huge applause from everyone in the crowd.



All over the weekend it was possible to breathe an air of friendship, great harmony and cordiality around the whole event. Everyone coming to the stands brought a little bit of themselves in willingness, kindness, free time, glee or even a sweet cake to contribute to make a really good show (Federica Laviano... your brownies were something special!).

Regardless of the winners and awards, this contest was a true success and shows great promise to evolve into something better for future shows and it has already been confirmed by the LUDICA Staff for next year.

The chance to educate a new generation to look beyond the latest phone, tablet or game console and to create something with their very own hands has been the greatest success for this initiative. I feel that nowadays it is us, the painters, who have a moral duty to bring new people into this hobby and with the right attitude we must pursue it with passion and keep it as a little peaceful place where we can seek refuge from the stresses of everyday life. What a beautiful place it would be where a father can share a passion in a hobby with his own sons and daughters? So what's in store for next year's show? Who knows, but for me, it will be impossible to miss! PS: My little personal satisfaction, I won the Gold Award in Standard Painting Models over 54mm. Yeah!

By **Martyn Dorey**

# Unboxing

## Nocturna's Uther Pendragon

Material: **Resin**Scale: **54mm**Price: **28.00 €**

Available from:

**Nocturna Models**[nocturnamodels.com](http://nocturnamodels.com)

Uther Pendragon is a legendary king of sub-Roman Britain and the father of King Arthur.

Uther is best known from Geoffrey of Monmouth's History of the Kings of Britain (1136) where he is the youngest son of King of Britannia Constantine II. His eldest brother Constans succeeds to the throne on their father's death, but is murdered at the instigation of his adviser Vortigern, who seizes the throne. Uther and his other brother Aurelius Ambrosius, still children, flee to Brittany. After Vortigern's alliance with the Saxons under Hengist goes disastrously wrong, Aurelius and Uther, now adults, return. Aurelius burns Vortigern in his castle and becomes king.

With Aurelius on the throne, Uther leads his brother in arms to Ireland to help Merlin bring the stones of Stone-

henge from there to Britain. Later, while Aurelius is ill, Uther leads his army against Vortigern's son Paschent and his Saxon allies. On the way to the battle, he sees a comet in the shape of a dragon, which Merlin interprets as presaging Aurelius's death and Uther's glorious future. Uther wins the battle and takes the epithet "Pendragon" and returns to find that Aurelius has been poisoned by an assassin. He becomes king and orders the construction of two gold dragons, one of which he uses as his standard. He secures Britain's frontiers and quells Saxon uprisings with the aids of his retainers, one of whom is Gorlois, Duke of Cornwall. At a banquet celebrating their victories, Uther becomes obsessively enamoured with Gorlois' wife Igrerna (Igraine) and a war ensues between Uther and his vassal. Gorlois sends Igrerna to the impregnable

castle of Tintagel for protection while he himself is besieged by Uther in another town. Uther consults with Merlin who uses his magic to transform the king into the likeness of Gorlois and thus gain access to Igera at Tintagel. He spends the night with her and they conceive a son, Arthur, but the next morning it is discovered that Gorlois had been killed. Uther marries Igera and they have another child, a daughter called Anna (in later romances she is called Morgause and is usually Igera's daughter by her previous marriage). Morgause later marries King Lot and becomes the mother of Gawain and Mordred. Uther later falls ill, but when the wars against the Saxons go badly he insists on leading his

army himself, propped up on his horse. He defeats Hengist's son Octa at Verulamium (St Albans), despite the Saxons calling him the "Half-Dead King." However, the Saxons soon contrive his death by poisoning a spring he drinks from near Verulamium.

Uther's family is based on some historical figures; Constantine on the historical usurper Constantine III, a claimant to the Roman throne from 407–411 and Constans on his son. Aurelius Ambrosius is Ambrosius Aurelianus, mentioned by Gildas, though his connection to Constantine and Constans is unrecorded.

Now that you know a little bit of this character as well as a bit of history of England, although some will argue he is legend and not history, I am not here to do so.

The figure comes as a seven part kit packed in a hard, clear plastic blister style box and all the parts are contained in a zip lock bag within the box which has a colour photograph of the model stuck to one face.



Parts consist of the cloak, two body sections, a rock for the figure to stand on and a small piece of card with the sword, scabbard and the hilt decoration. Detail of the parts is very good and only minor cleaning of pour/vent points is needed along with some light mould lines and certainly nothing that will detract from the detail of the model.

This is a simple kit to put together and the four main parts will have no issues once cleaned up and glued; there is, however, a small area where the right leg meets the underneath of the skirt that may need a small amount of putty when it is cleaned up. The only other issue I see with this kit is that the sword and scabbard are very thin and therefore very flexible the sword especially is going to need the hot water treatment when it is removed from the card.

### Conclusion

A very simple figure to put together and I am sure that it will give many people (including me) a lot of joy to paint.

The very best  
**EXPOSÉ**  
new releases

The Battle of Hastings

Company: MJ Miniatures

Scale: 1/10th

Contact: [www.mj-miniatures.co.kr](http://www.mj-miniatures.co.kr)



Santa's Advice

Company: Andrea Miniatures

Scale: 54mm

Contact: [www.andreaeurope.com](http://www.andreaeurope.com)



Gannicus

Company: Scale75

Scale: 75mm

Contact: [www.scale75.com](http://www.scale75.com)



Angevin Knight first half XIV Century

Company: Romeo Models

Scale: 75mm

Contact: [www.romeomodels.com](http://www.romeomodels.com)



ZEYBEK – Ottoman Irregular Militia

Company: Romeo Models

Scale: 75mm

Contact: [www.romeomodels.com](http://www.romeomodels.com)



"HOSTUS"

Company: Romeo Models

Scale: 75mm

Contact: [www.romeomodels.com](http://www.romeomodels.com)

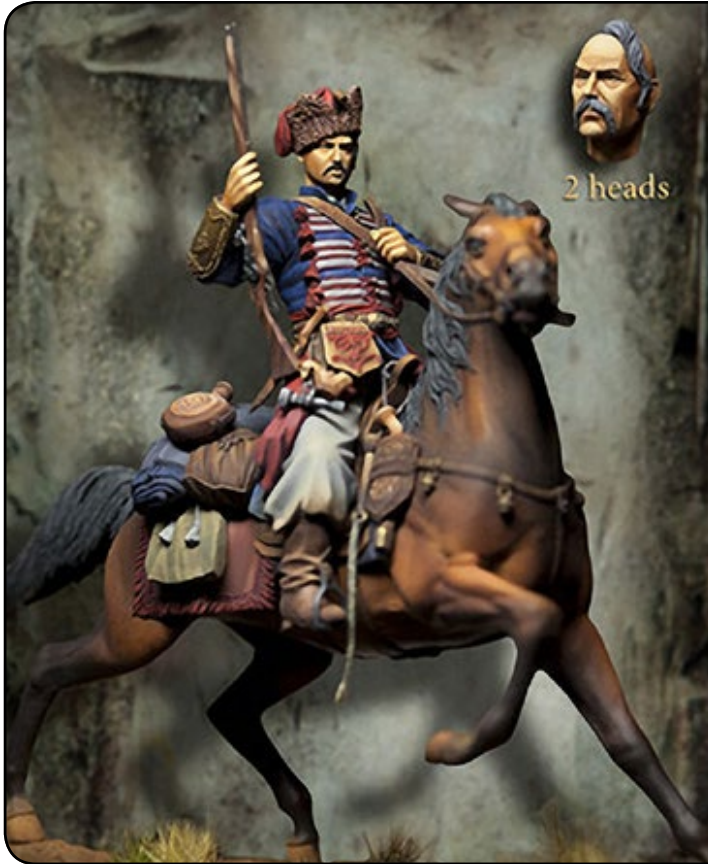

Zaporozhian cossack "Otaman"

Company: Irbis Miniatures

Scale: 75mm

Contact: [irbis-miniatures.com](http://irbis-miniatures.com)



Brother of the Coast Tortuga, 1668

Company: Heroes and Villains Miniatures

Scale: 1/12th

Contact: [www.hvminiatures.com](http://www.hvminiatures.com)



British Rifleman

Company: Ares Mythologic

Scale: 75mm

Contact: [www.aresmythologic.com](http://www.aresmythologic.com)



Male and Female Sci-Fi Powered Armour

Company: Hasslefree Miniatures

Scale: 32mm

Contact: [www.hfminis.co.uk](http://www.hfminis.co.uk)



Leonella

Company: Draconia

Scale: 54mm

Contact: [www.aresmythologic.com](http://www.aresmythologic.com)

Cloepunk

Company: Draconia

Scale: 35mm

Contact: [www.aresmythologic.com](http://www.aresmythologic.com)





Female Mage with Staff

Company: Dark Sword Miniatures

Scale: 32mm

Contact: [www.darkswordminiatures.com](http://www.darkswordminiatures.com)



Elven Warlock

Company: Dark Sword Miniatures

Scale: 32mm

Contact: [www.darkswordminiatures.com](http://www.darkswordminiatures.com)



Female Elven Dual Wield Rogue

Company: Dark Sword Miniatures

Scale: 32mm

Contact: [www.darkswordminiatures.com](http://www.darkswordminiatures.com)

Night Lords Night Raptors

Company: Forge World

Scale: 32mm

Contact: [www.forgeworld.co.uk](http://www.forgeworld.co.uk)





Morko

Company: Leben Studio

Scale: 59mm

Contact: [lebenstudio.blogspot.co.uk](http://lebenstudio.blogspot.co.uk)



Judge Death

Company: Dark World Creations

Scale: 70mm

Contact: [www.darkworldcreations.com](http://www.darkworldcreations.com)

### Iron Hands Medusan Immortals

Company: Forge World

Scale: 32mm

Contact: [www.forgeworld.co.uk](http://www.forgeworld.co.uk)





by Mario B Delgado (mbd)

# Unboxing

## Games Workshop's

# Mirkwood Rangers



### I Hate GW!

Well, this is not a good way to start a review of a model, but it is the truth and a way to grab your attention!

I also thought it was a good way to finish the year, with a review of a GW model which is not something that you often see in our magazine.

Why do I hate GW? After all of the changes in recent years as well as this year, it is no wonder that GW deserves, as a hobby aficionado, my hate.

I hate GW because despite their nonchalant attitude to the hobby aficionado and their poor choices in marketing which have caused all of the problems and unrest in the hobby this year, they still produce some of the best models on the market.

With the release of the Hobbit, (the new trilogy of films based on JRR Tolkien's books), the new models from GW adopts a pace that supports the releases of the successive parts. The Desolation of Smaug hit the screens recently and the movie features elves from the Mirkwood forest, so this month GW has released several models depicting elves.

Material: **Plastic**

Scale: **28mm**

Price: **£25.00**

Available from:

**Games Workshop**

[www.games-workshop.com](http://www.games-workshop.com)



Well, hope you like and enjoy these as much as I plan to...I already have a diorama in mind and will get working on it. See you all next year!



When I saw the models of the Rangers of Mirkwood forest in some of the fan blogs (ones that GW had tried to stop and silence in the past), I knew I had to get a box.

GW always does its best work when using plastic to produce its miniatures and this time they have done all the right things. They are "true" 28mm scale models of very dainty elves. The models are full of character and very dynamic and are crisp and full of details despite their size. Also, the "engineering" part of it has been well thought out and the fit of the pieces is brilliant with little or no filling needed.

Another of the thorns that modellers had when buying GW models is the price, but this time it is fairly reasonable. A box of ten nicely done wood elves cost £25, so you pay £2.50 for each model, which is not a bad price on these days.

# What's on the Market?

a regular look at some of the hobby tools available



By **Martyn Dorey**

This month I want to have a look at what is out there for doing groundwork. All too often at the shows, I see models and not just figures that have had a lot of time, love and attention spent on them and then the modeller thinks that is it and leaves it at that stage, paying no further attention to what the model is on or the story it is to portray.

## Groundwork

▶ For me and for a lot of other folks out there the model is part of a story; it is just not a case of painting the figure and leaving it at that. You need to be able to give the person that is looking at your work the story that the figure is portraying in your mind; otherwise, they may not understand the scene or spend as much time looking at all your hard work. It is also part of the presentation, but that part is for another issue.

So for groundwork (let's take a single figure as an example), just think of a figure you have in your collection. It could be a wargames figure, a figure portraying an American GI in Vietnam or many others. A lot of these figures will come with a very small base or a gaming base that is plain and simple and most of the time they will be too small for the figure and will need to be incorporated into a larger base or disregarded and a whole new base planned and made that is more suitable for the model. Let's face it a 75mm figure on a two inch by one inch base isn't going to look good on a two inch square or larger plinth is it?



Sometimes a figure will come with a decent sized base that will fit straight onto a plinth, but does it portray what you want from the figure? For example, take the editor's paint job of the limited show edition figure that Chris Clayton did for the SMC Show. The base is adequate for the figure and would do on its own but doesn't really tell much of a story for the figure apart from that of she has just cut off the head of a monster and is stood on a rock. So Shane has expanded this to his own story and produced this:



At this point I would like to mention that I am not going to continue with how this base has been built as it is not my project to do so, but instead (as with all the "What's on the Market" articles) I want to cover some of the things that are out there to help us achieve this type of base.

These days, it is not just a case of choosing an appropriate plinth or plaque to put our model on that is not too big or too small, but think before buying it what you intend to do with it and the model that is going to go on it. Do you need to do some carving of the base to give the sides or one or two of the sides the look of sloping ground from the top of the base, if so would you pay £10 or a lot more for a polished wooden base when you could buy a resin base cheaper and work with it a lot easier?



Once we have the base idea in our heads, what is out there to help with this project, well (besides the usual putties to help bulk things out and even sculpt a few parts), there is also something that pattern makers and architects and used for prototyping called Model Board. This is a polyurethane board that comes in assorted degrees of hardness some of which need to be machined and others which are suitable for hand carving. The downside to this stuff is that it comes in 500 x 500 x 50mm sheets which means it is a lot of money for us modellers to get this and cut off just a small portion for what we want. It can be bought from some sites (and a little bit of searching) in 175 x 75 x 6mm pieces though, but you need to spend a lot of time looking for it. It is worth looking for though in the smaller sizes, though as it has a multitude of uses for the modeller in all scales, be it just simple steps and walkways or for making walls and parts of buildings. Once sealed, it can be painted to give very convincing effects.

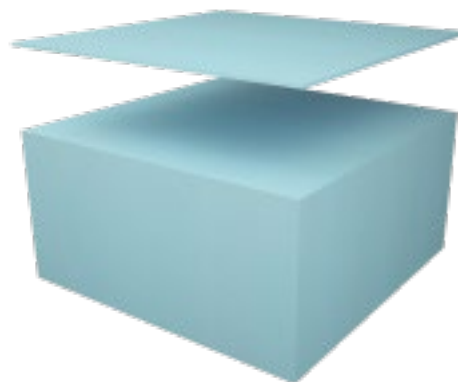

Craft foam is another option to Model Board. This is a fairly hard styrene foam board and is often found to be the stuff that game boards are made of; a lot of modellers will use it as a core and then put a covering of green stuff or other putty over it. It comes in blue, green or pink sheets and for those in the building trade it will be more familiar as the hard foam boards that are used as insulation under floors. It is easily cut with a knife although a lot of people will use a hot knife system to get the best cut; it can also be carved easily but will need to be sealed before painting. It can be purchased in various thickness's from 3mm up to 100mm as well as varying sheet sizes. It has a downside, though, which is that is you will need to buy a lot more than you will probably need unless you buy it as a club in bulk.



There is also the Vallejo range of Stone and Water textures, these are a range of acrylic mediums in various textures and colours; the Still Water is excellent for ponds or puddles where no ripples are needed, but be warned if you put it on too thick or try to speed up the drying there is the possibility that it will crack. It also has the habit of finding the smallest gap to run away from and many a modeller has filled up the area before they have finished for the evening with Still Water only to come back to it the following day and find it has escaped and is now all over the wife's table...The other drawback to this stuff is that it will shrink as it dries, which means that you are going to have to apply it as several layers making sure that the last layer is dry before applying the next. There is also a Transparent Water in the range, which is thicker and therefore allows the modeller to sculpt ripples or waves into it as

it dries; it can also be used to make waterfalls by spreading an amount of it onto plastic and then when it dries, peel it off and cut and place it where it is needed.

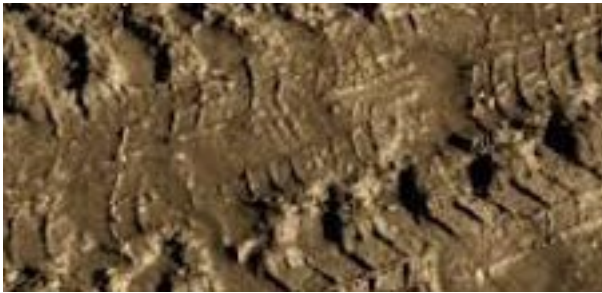

A lot of this range is also pre-coloured, so if you want a tarmac road surface then the Black Lava is ideal as it can be put down and smoothed out to give you this type of surface. For the wargamer that is basing several figures, then the Sandy Paste or the earth colours can be very useful as when they are spread out around the base of the figures and allowed to dry, all you need to do is give them a quick dry brush. For the ones that are not coloured or if you just want to change the colour of some of the others, then acrylic paint can be mixed in. The Grey Pumice is quite rough and therefore makes a good substance for filling gaps and roughing out ground areas. All can be painted once dry and the water effects ones can be applied over a painted surface. Prior to drying, you can also press shapes into the mix to simulate



tyres, tank tracks or even the boot prints from figures and animals if you so wish.



Also at our disposal is sand and grit, which mixed in with PVA glue can give some good basic ground coverage. For really fine sand, then the sand you can buy for play pits is about as fine as you are going to get, but you can also get the Gale Force 9 basing grits; these come in superfine, fine, medium and course grades, but if you buy one of each and mix them together you have something that will last you a long time and give you a variety of grades in one go. Games Workshop used to do a very good basing sand that had small stones it but unfortunately they have changed the product and the nearest you will probably get to this now is builders sand, but the stones can be a bit on the large side and the sand too small/fine.

If I have used sand or gravel, I usually seal





it with a watered down coat of ink and PVA; once this has dried you should have a nice hard surface similar to that of the stone & earth textures and it is ready for painting. At this stage, a lot of people will dry brush but I have found you will get a far more realistic effect from using pigments.



Static Grass and Flock is something else we have to play with in our arsenal of modelling materials. Flock is something I have grown to hate over the years as it just doesn't look right when compared to static grass. Static grass now comes in various lengths and colours, I have even seen it in blue! (fur like lake anybody?) Gale Force 9 produce a selection of both flock and static grass mixes/blends but they tend to be all one length, whereas the German based company MiniNatur produce a range of single colours in 2mm, 4mm and 6mm lengths. All too often I see models that look like they are standing on the green of a golf course because people just put the flock/static grass over all of the base, it only needs to be put down in small areas. Break up the static grass with clumps of foliage if need be trust me it looks a lot more interesting ☺

I mentioned MiniNatur above; for those in the States you will know this as Silfor. The range is a cross over from the model railway side of the hobby and is huge. Not only tufts in various scales, but different seasons as well. They come with leaves on or with flowers and they do flowers as well



which you just need to cut to the length you want and then stick them in place.



It is easy to use; just pick off a tuft from the backing they are on and put a drop of superglue on the bottom of it and place it where you want it. They also do an excellent range of tree foliage and crop strips, so with this stuff your imagination is the limit.



What about jungle plants I hear you ask? Well for the more exotic plants and ferns we need to look towards brass etch. Not so easy to find as the MiniNatur, but still some useful plant types. I think most of the stuff I have found on the market has been for the doll's house market but there are a couple of sellers out there that do the smaller scales such as 28mm. Although the photos shows ivy and tree leaves you can get ferns and other styles, my advice when using brass etch is to prime and base coat it whilst still on the frets, then cut it off with pair of snips. The final painting can then be done with the plant in place along with any touch up needed to the base coat due to bending the piece to shape in the required position. Sounds like a lot of work, doesn't it? It can be very effective, though, especially when mixed in with other products.

Another alternative are paper flowers and leaves. The ones I have tried have been produced by Green Line and are sold through Fredericus Rex. They come in a variety of scales and either printed on thin green card or plain. For most of these, you will need to produce your own stem/stalk and a certain amount of painting and highlighting will be required both before they are put in place and afterwards. Possibly not as effective as the brass etch, but if you need to have the right scale, then this is probably the easiest to get hold of.



side of the hobby and is produced by a company called Modelmates. I will admit at this point that the more I use their products, the more I like them so stand by for a more in-depth review and use of some of these in the future. I digress, though, so back to the subject. The Modelmates snow effect is a spray can and the trick with using it is all about nozzle control. If you fully depress the nozzle it comes out very fast and is hard to control and hence you will get a very heavy covering.

However, a little practice to only press lightly on the nozzle will mean that you can control how much comes out and by also altering the angle that you are spraying from, you can even leave some areas uncovered by the snow spray such as under obstacles and trees just like they would be in real life.

As with most of the Modelmates products it remains workable until sealed, which means if you don't like how it has gone down you can remove it; the downside to this is that you will need to seal it in place especially if you plan on taking the piece back and forth to shows, but this isn't a problem as a light spray with Dullcote will easily do the job. This product is by far the most effective and realistic snow I have come across.

And that folks as they say is the end of the article for this month.

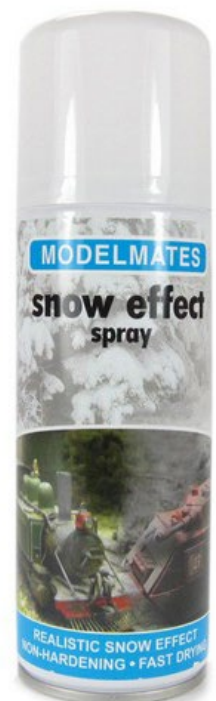

Lastly, I want to mention two products for winter groundwork. I know a lot of people try to avoid this sort of scene purely because the effect is so difficult to achieve and make it look real. Most of us are familiar with micro balloons which is sold as snow and Gale Force 9 sell it in pots; if you are not careful the damn stuff goes everywhere ☹️. I have seen people use Bicarbonate of Soda, but this can yellow after a while. You could also use the White Stone or White Pumice from the Vallejo textures range but this will dry hard and may not give the effect you are after. Vallejo also does small bottle of what they call "Foam & Snow" which is used to give small ripples on snow caused by drifting or can be used to put the whites on wave crests as well as simulating that last bit of snow left around rocks or on north facing cliffs.

One of the best products for snow, however, that I have found is yet another cross over from the railway model

# advertise in this space

Click [here](#) for more information

# GROUNDWORKS

Whatever the project, whatever the need.

We have the tools for you.



## Stockists of

- MiniNatur
- Vallejo Stone & Water Effects
- Modelmates
- GF9



[www.modeldisplayproducts.co.uk](http://www.modeldisplayproducts.co.uk)

# & PUTTY PAINT

## Giu's Robot Repairs

by Raffaele Picca



PRO

Website

Phew, I don't know what to write here. Finally this big project came to an end....my first interactive, photo taking, music playing diorama with a lot of blinking lights! Be sure to check out the video on YouTube: [YOUTUBE LINK](#) or the big report on Massive Voodoo: [MV LINK](#) I hope you enjoy it!



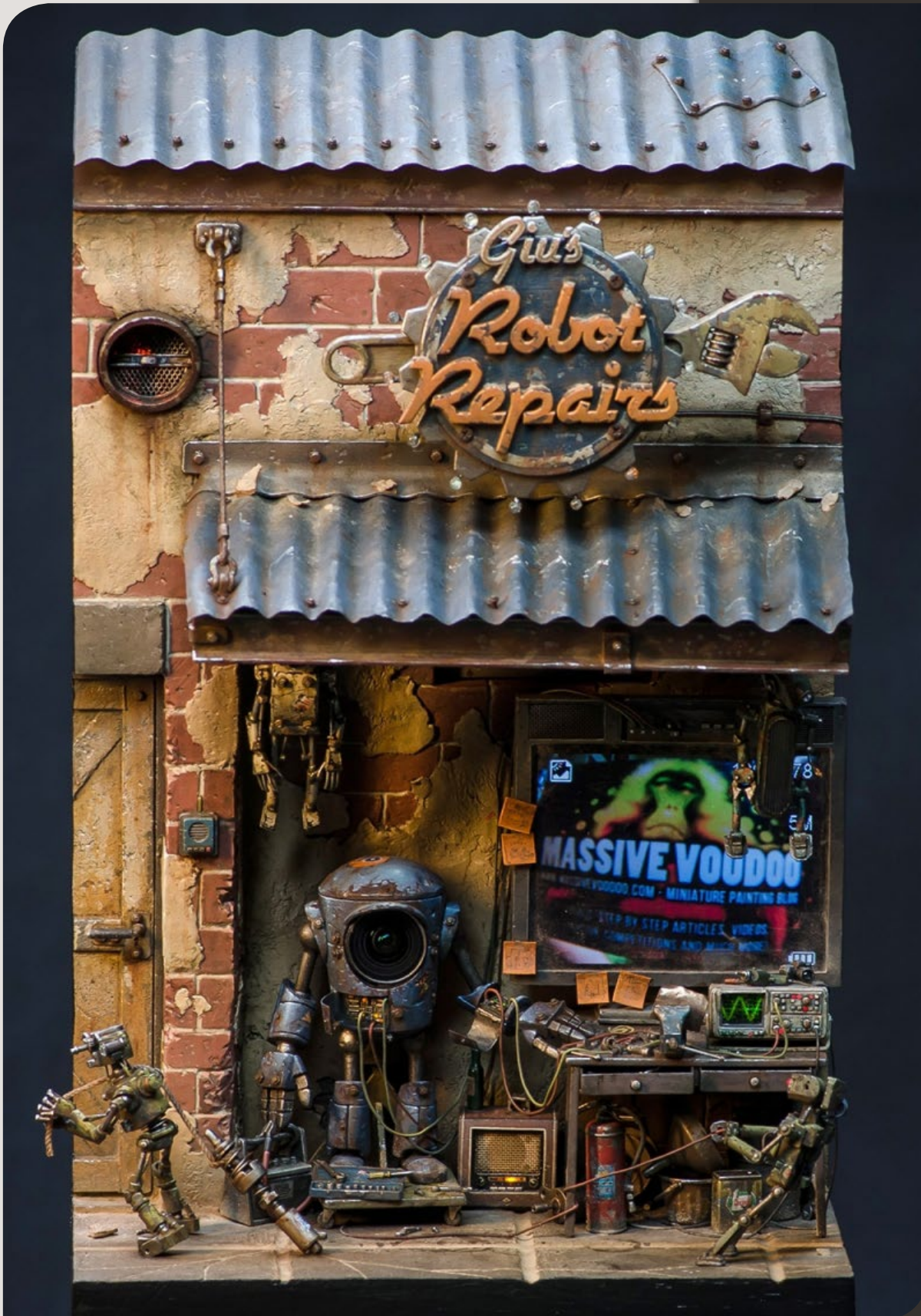

# & PUTTY & PAINT

## Waaaaaagh!

by Enrique Velasco



PRO

Website

I had in mind this idea for months, a big scale Warhammer 40000 ork, but obviously, it's impossible to buy one. If you want to paint one, you need sculpting skills or use a previous sculpt and make a conversion. I chose this last option. I used as a base for the conversion the superb ork sculpted by my italian friend Carmine "thor" Giugliano, based on the Paul Bonner's artwork.





# & PUTTY PAINT

Kids playing on abandoned cannon in Russia 1944

by Javier González

PRO



 Website

The 10.5 cm leFH 18M was the standard German divisional field howitzer used during the Second World War. It was designed and developed by Rheinmetall. After the war broke out, in an effort to get more range from the basic leFH 18 design, a muzzle brake was fitted and the recoil system adjusted to allow the use of a more powerful charge and new long-range shell. Generally it did not equip independent artillery battalions until after the Battle of Stalingrad in 1943. 53 were also exported to Finland, where they were known as 105 H 33. Some time ago, I saw on the internet the picture that showed some children playing in an abandoned cannon in Russia and it immediately caught my attention. It's an idea that is very close to the kind of models I want to do; small stories with soft conversions that are far away in meaning from the classical soldier posing, yet very close to military models. As it was a not a very complex project, I decided to give it a chance.

By **Federico Sorgi**

# bust painting tutorial

# BOROMIR

by Knight Models

▶ When I saw the bust of Boromir (produced by Knight Models) being showed at the stand of Bestsoldier during Monte San Savino Show, I decided it had to be mine. I had been impressed by the sculpt of the bust, from his pose and expression and especially by the presence of large surfaces that have really allowed me to have fun during the painting process, including the cloak that would give me a chance to try my hand at freehand with a decorated cloth.

Assembling did not present any problems for me; I found only a few bubbles that were filled with putty.

Before I start the painting, I studied the model to understand which parts I would paint with oils and which with

acrylic. I decided to paint the face completely with oil colours, starting with a base of Tallarn Flesh. For leather, metal, fur and hair I decided to use a mix of oils and acrylic techniques, painting lights and shadows with acrylic colours in an impressionist manner and blending later with oil colours, defining details and cleaning up any brush strokes.

To paint the cloak, I'll used only acrylics to achieve a matt finish particularly suitable for the appearance of cloth. The shield will be painted later, because the copy of the bust was their last one and in the confusion of the event we were unable to find the shield, so it will be sculpted by my friend Erika Tosello.





### CLOAK PART 1

After a coat of black surface primer, I painted the cloak with a dark wine colour, achieved by mixing Andrea colour (AC)-18 Reddish Brown, Dark Red Andrea New (NAC)-30 + Black Dragon Model Master and Tamiya X21. After the base, I've added a little bit of Titanium White Maimeri to do two steps of highlights using a very broad brush (a W&N 2 that I stole from my girlfriend), so I was able to get the highlights

very large with no gradient between them because I want to get a particularly soft and voluminous surface without giving too much detail to the area, a good background that does not disturb the damask design that I would be adding later. For now, the work of the cloak ends here, in order not to ruin the damask during the painting of the other areas.



### ACRYLICS FOUNDATION

After painting the first lights on the mantle, I've painted the base colours over the entire bust.

Raw umber Maimeri for beard, hair and fur. Bruno Van Dyck Maimeri + Black Dragon Model Master. for the leather shoulder strap of the shield. Bruno Van Dyck Maimeri for ropes and strap's decoration. Tallarn Flesh Games Workshop + Tamiya X21 for skin. Maimeri Navy Blue + Black Dragon Model Master for dress. Steel Oil VMC. for metal parts. Ochre Maimeri for the collar's decorations. Ivory Maimeri for sclera of the eyes and Maimeri Navy Blue for pupils.

I decided to paint the eyes immediately, because they help to establish the expression and understand the final look of the bust during the various stages. I've highlighted the iris adding white to the base colour; I've painted the pupils with a black dot and I've added a white dot for reflection. I've also given a wash with oil Rose Red around the sclera and I made it shiny with a coat of Gloss Varnish VMC.

## FACE PART 1

In this picture, I show the palette that I've used to paint with oils.

The palette is the same as that used for the skin in the tutorial dedicated to the Revolutionary found in [issue 5](#) of FPM.

The palette is composed of Black Ivory, Raw Umber, Burnt Sienna, Terra Rosa, Dark Naples Yellow, Titanium White; in the centre, there are Rose Red and Violet. All the colours I use are Van Dyck, except the Terra Rosa which is from Winsor & Newton.



As a first step, I've greased the entire face, positioning the lights and shadows to begin defining the face's volumes.

I chose two colours from the palette, a medium light tone and medium dark tone, corresponding to Naples Yellow + Terra Rosa + Burnt Sienna. I've painted these two colours on most of his face, respecting the lights and shadows. After that, using a flat synthetic brush I've blended colours, covering also the remaining parts of base colour. Next, I've painted a shadow under the eyelids using a dark tone containing a little purple, added to cool the tone.



In oil painting it is very important to never use too much paint, otherwise you knead the surface, making it impossible to paint on. It would be like trying to write with a pen on a cream cake. If that happens, the solution is removing the paint or letting area thoroughly dry.

For the next step, I've chosen three different colours from the previous step (a very strong light, a dark shadow and a warm medium tone with a red component) and I've painted facial details adding red on the nose and cheeks.



Next, with the flat synthetic brush, I've stippled the piece making sure that these colours smoothly blend with the colours of the previous step. I've used the very strong light in the light areas of the face, so that the subsequent blending with the underlying colour gave the result of a medium tone of light. I've followed the method for the painting of the other colours.



In the next step, I've used two cold shade tones.

For this step, I initially deployed the colour in little dots then with the same brush I've spread the colours taking care not to cover the entire area that I wanted to paint. Taking another clean brush, always W&N, I then blended colours out covering all of the area I wanted to paint.

Once happy, with a lighter tone, I painted the sides of the nose, the outer edges of the eyelids and temples. Then with the darker tone, I've painted the inside corner of the eyelid and the deep wrinkles on the sides of the nose.



With Burnt Sienna I've painted little dots in the area where there should be stubble; after that, I blended with a stippling motion the area with a flat brush.

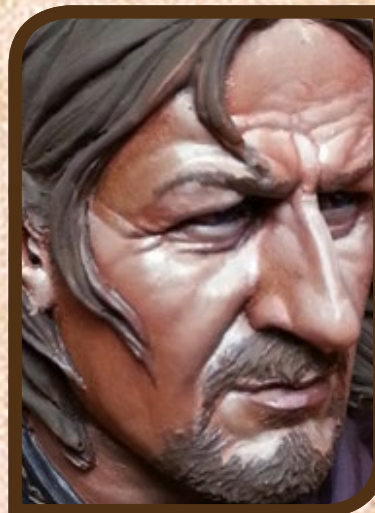

I've used Burnt Sienna to warm some areas of the face, such as the sides of the eyelids, temples, forehead wrinkles and the small areas on the cheeks, always blended with the technique of dotting followed by stippling.



With Terra Rosa, I've added more shadows to the forehead and nose.

At this stage, I've used ochre, taking it directly from the tube. I then painted and blended only in some areas to make it a more realistic skin tone, differentiating in some parts.

This photo concludes the first stage of the process for the face. To begin the second phase, I must wait until the oil paint is completely dry.

#### HAIR, FUR, BEARD

With a palette Maimeri acrylics consisting of raw umber, ochre and Ivory, I then painted the beard, eyebrows and hair, ignoring the carved texture. I've obtained a series of areas much lighter and stronger than the final colour, because in the next step I'll apply a shadow wash over these parts.



I've prepared a palette for oil paints on a piece of parchment paper (this is important because the paper absorbs some of the oil, making the colour less wet and facilitating the fine lining of the texture of the hair), consisting of Cassel Earth, raw umber, Gold ochre and Naples yellow light. With this palette, I started giving a wash with raw umber, followed by another wash of Cassel earth. It's important to allow this time to dry before applying the washing; to expedite the process, I use an electric oven setting the temperature to 100 degrees and using only the top grill for 10 minutes. **DON'T DO THIS WITH PLASTIC OR LEAD MODELS.**



Using the oil colours on the palette I've start to repaint the hair. Starting with the larger clumps, then tightening the area of paint more and more until I've finally painted texture of the hair. You'll need to use lighter colours for each stage to achieve for the result you want in the end.

At this stage, I've given the hair a wash of Cassel Earth, to bring out the texture and darken the overall hue of the hair colour.





With a mix of Burnt Sienna and Cassel Earth, I gave a general wash the hair, working on some deeper areas and in some midtones to warm up colours and give the hair an aspect more similar to a blonde-brown colour.



## FACE PART 2

While the hair is drying, it's time to go back to working on the face now that has completely dried. You'll notice that the face looks a bit darker than the previous phase. This is because the paint has darkened while drying. Before beginning this new phase, I had to study what was lost during the drying process. It's best done in front of a window so that natural sunlight strikes him in the face, this is because the light from above casts shadows on satin surfaces that can deceive the eye.

I have mixed a new palette of colours using the paints I previously used for that face, but without using the purple and Rose Red.

Restarting from the front, I've detailed the shadows and high-lights to bring out the wrinkles and expression of the face. At this stage, take care to not paint too light or dark as it will compromise the natural facial expression.

During this step, it is necessary that the colours are never too glossy, otherwise the lamp create a shine on the surface. You can put the model in the oven for a few minutes to speed up drying while you prepare yourself a cup of coffee or play with the cat.

After this step, I've dried it and with very thinned darker colours I apply glazes to better define the details of the face.

For the lips, I've used the same palette, but this time added some Rose Red.

As a last step, I've glazed cheeks with Burnt Sienna and I added a glaze of Rose Red on cheeks, nose and forehead wrinkles; anywhere where the flesh is thicker and blood will pump.





DRESS, ROPES, METAL PARTS

After painting the face and hair, I started to paint the clothes. After an initial base of Navy Blue and Black Dragon, I've painted highlight and shades in the normal manner with a mix of white or black (the Maimeri this time, I bought the big jar) and Prussian Blue

with base by adding to the highlight colour larger amounts of black and blue until the transitions are smooth.

In the same way, I've painted the shadows with black and then glazed in the mid-tones with Navy Blue

In this step, I've blended the lights previously painted

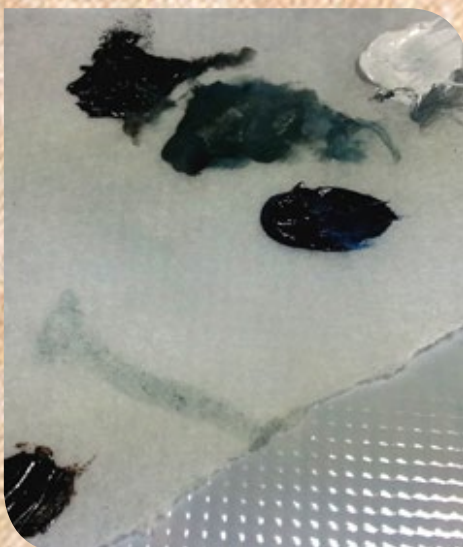

This is the pallet for the tunic. I've prepared oils using Prussian Blue, Ivory Black, Burnt Umber and Titanium White.



I've painted lights and shadows on the tunic and then blended the colours by stippling the surface with a synthetic flat brush.



In this step, I've painted the wrinkles of the leather edge of the tunic with a 000 W&N brush and I've added some cracks to the to make the leather surface more interesting. I blended colours with a clean 000 W&N.





After drying in the oven, I've applied a glaze in the shadows with Burnt Umber

In this step, I've painted floral decoration on the edge of the tunic, repeating a simple design consisting of a dot in the centre surrounded by five dots. The decoration was painted

in oils, using the same colours I used for the hair.

The decorations were first painted with a medium dark tone and then the dots were highlighted on top of the garment.



The next step is painting collar. The collar was painted using acrylics: black, raw umber and white, doing highlights along the edge of the seam. Decoration of the collar was painted in oils using the hair palette, arranging the colours of dots close together, so as to simulate the seam.

Along with the collar, I also painted the shoulder straps of the shield and the ropes ties that hold the cloak.

The shoulder straps of the shield are formed by two types of leather; the bottom darker and cold and the top most light and reddish.

The dark leather was painted directly with black oil paint; umber and Naples yellow where used to lighten the upper areas. The reddish part was instead painted with a colour palette including black, Burnt Sienna, Terra Rosa and Naples yellow. The technique used is the same for both parts and after a first general application of lights and shade, I've painted in the cuts and cracks to give a extra texture to the surface.



In this step, I've taken up the palette of the face to add more highlights to the face and to the wrinkles on the sides of the nose I've sketched out the colour.

I also highlighted the ropes of the cloak, with Burnt Umber and Naples yellow, profiling the texture of woven wire.



After painting highlights on the face, the paints were again blended with the synthetic brush.

I also use a wash of Tamiya Smoke on the metals, followed by a wash of Cassel Earth oil paint in the recesses.



## CLOAK PART 2

Finally, I highlight the metal with Chrome Model Master enamel, painting the details with a toothpick. Using a toothpick makes sure the colour doesn't spread, depositing the pigment in one place and making the metal much brighter.

As you can see in the picture, I have also started the damask design on the cloak.

When you want to paint a damask the first thing to do is to find the geometric structure behind the design that can be repeated and drawn on the model with very thin lines. You can help yourself by making the first drawing with a slightly lighter colour than the base, so if you do make a mistake you can correct it easily.

In this particular case, I've started from the design of the branches, drawing them with black acrylic.

At this stage, I have added all the elements of the damask design which were ignored in the first phase of the planning of the freehand. I took great care to maintain the same colour balance between the design and background in all parts of the fabric.

After completing the drawing, I gave a black glaze to blend layers of colour. Then, with a soft synthetic flat brush that allows me to spread paint without leaving stains of water and colour, I work on the shadows with successive layers of glazes.

In between each glaze, I dried the area with a hair dryer and wait for it to cool down. This is because warm paint comes off easily.



For the cloak's fur, I've painted a base of black and Burnt Umber acrylic; I then highlight the clumps of the strands adding Burnt Sienna and more and more ochre to slowly define the individual hairs of the sculpt. Then adding Naples yellow, I highlighted the tips of the strands. To finish, off I've applied a wash of Cassel Earth oil paint.

And with this step coming to an end, bust is complete.

#### TIPS & TRICKS ☺

From the beginning, I chose a handhold on the piece, the fur trim of the coat and that piece was painted last.

Every time that I make a palette with oil, I prepare it on a piece of parchment paper that absorbs some of the oil. Then I put aside the palettes so if I need it for some corrections I can resume using them easily.

The bust was painted over several days; every morning before resuming work, I study bust carefully under the lamp and in sunlight the do any necessary corrections. This is because there might be a slight shift in the brightness of the colour when the paint dries.

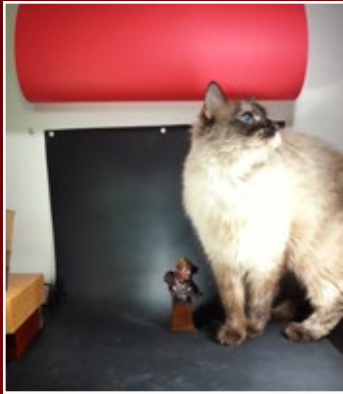

No cats have been harmed during the writing of this tutorial. Thanks to my girlfriend Federica, for helping me write the article and to Erika, she doesn't know yet, but she has to sculpt Boromir's shield for me ☺



So...I hope this tutorial has been clear and helpful but if you have questions or if you want share your opinions with me, feel free to mail me at my facebook page [here](#).





By Martyn Dorey



# Unboxing

## Dark World Creations

# Judge Anderson

Every young boy knows about the 2000AD comics and therefore I doubt there are many people that need much of a background on this particular figure, but just in case you have been living under a rock, here is a quick intro.

Material: **Resin**

Scale: **70mm**

Price: **£34.80**

Available from:

**Dark World Creations**

[www.darkworldcreations.com](http://www.darkworldcreations.com)

Judge Anderson is a member of the PSI Division, which are Judges who possess psychic powers. This allows her to read people's minds and use mental attacks. Judge Anderson was instrumental in stopping the first attack from the Dark Judges in Mega City One. Mega City One is one of the three areas to survive the nuclear war of 2070. It extends along most of the eastern American seaboard. Millions are crammed into skyscraper city blocks where unemployment is extensive and crime is of epidemic proportions and only the Judges guard the city from complete anarchy.

So there you go, you now know who Judge Anderson is.

The model comes in a thin coloured cardboard box and all the parts inside are protected by being sandwiched between

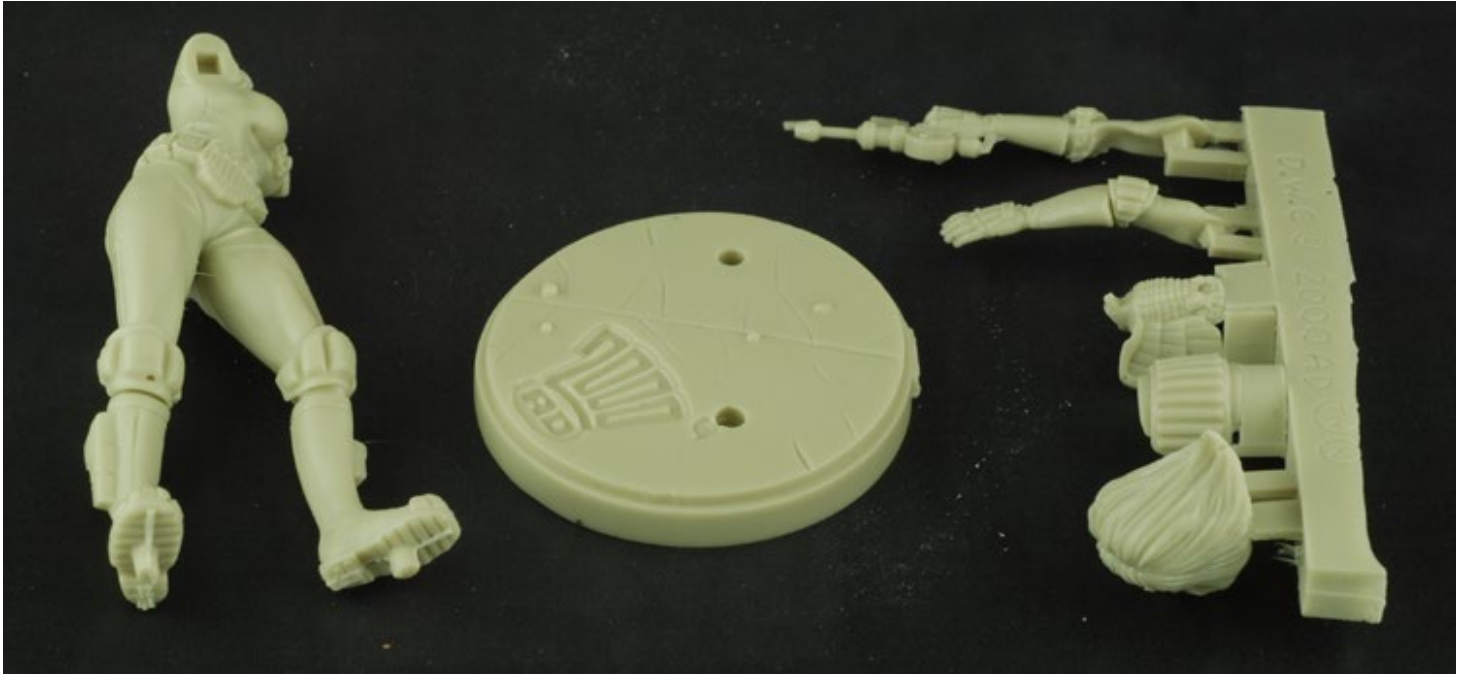

three pieces of foam and consists of the body, base with the 2000AD logo on it and a sprue which has the head, arms and shoulder pads attached to it.

These parts will need to be cut carefully from the sprue due to the way they have been set for moulding and subsequently cast; it is very similar to the old vinyl models in this respect. Mould lines on the pieces attached to the sprue are practically nonexistent, but there are a couple of air holes/bubbles on the eagle shoulder pad.

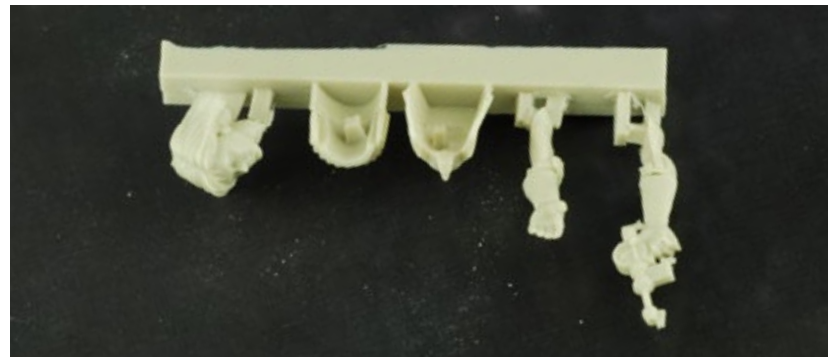

The body is reasonably cast, but there is a heavy mould line down the left and right leg and also the left boot which shouldn't be too difficult to remove with a bit of care, but the mould slip on the boot of this foot is not so good and will require a lot more work. There is also the remains of the casting plug and a mould line on the edge of the base to be removed. Why the caster located the plug on the edge face I do not know, because it means that as this edge has a texture that needs to be removed all the way around, otherwise it will look odd.



### Conclusion

An easy enough figure to assemble that is let down by some of the casting decisions. The resin is also not as firm as you might expect in a resin kit, which means there is some flexibility, especially with the arms. The mould slip on the boot is going to require putty rather than a scrape with the knife. Other than this, I feel the price is on the high side for a 70mm scale resin kit.





# 11<sup>TH</sup> Agram Arena Winter TOURNAMENT

This December saw the eleventh edition of Agram Arena Winter tournament in Zagreb, Croatia.

By Marko Paunovic



▶ The main event was the biggest Warhammer tournament in this part of Europe (apart from ETC) with a couple of side events like a Malifaux doubles tournament ( the first ever in Croatia) and various demo sessions of other tabletop wargames like Warhammer 40.000, Lord of the Rings/ Hobbit Strategy Battle Game, Flames of War and Infinity.

As usual, the tournament is free for all the participants (no entry fee) with soft drinks and refreshing beverages served throughout the event. Also, first time comers get one nights accommodation free as a part of our "try-once-see-if-you-like it" policy and lunch is provided for 10 Euros for both days. This is all possible due to the fact

that the Agram Arenas (both Summer and Winter) are cofinanced by Zagreb's City Office for Social Welfare as well as Zagreb's Community of Technical Culture as a part of their efforts for preventing unwanted behaviour of minors and youths. For more info, check out [www.ums-agram.hr/eng](http://www.ums-agram.hr/eng). The AAW 2013 event gathered a great number of players and hobbyists from Croatia, Serbia, Slovenia and Italy, most of whom like to return to UMS "Agram" events, be it in winter for the Warhammer or be it in summer for 40k or Malifaux tournaments.

The main event, the Warhammer Fantasy Battles tournament, consisted of five rounds spread over two days of gaming. On Saturday, there were





games played on great looking tables with fantastic looking Wild West buildings that were the spotlight of the event. Apart from the 20% of Malifaux competitors being female, that is... ☺ All the players agreed that the doubles format was great fun and took a lot of the stress away from the gaming because the games lasted a bit longer. The tournament organiser obliged the players and prolonged the games enabling all to finish.

three battles played and in the evening the tournament organizers arranged a visit to a local pub for some food and drinks. Although the players had so much fun they stayed until the early hours of the morning, the first round (fourth overall) on Sunday wasn't started late and after five rounds of gruelling combat on the battlefields of the Old Worlde, we had our Vampiric winner — Roko

*"It is always a great pleasure to play at Agram Arena Winter, to win even more so :). It has cool atmosphere, usually loads of snow outside, nice people and great, competitive gaming. Definitely the best WHFB tournament in the region!"*

The Malifaux doubles tournament was held on Saturday and featured





At the end of the event, but before the closing ceremony, (as AAW is the focal point of Zagreb's gaming community), all the annual awards were handed out— the various league trophies for Warhammer 40.000, Malifaux and of course, Warhammer Fantasy Battles. The closing ceremony consisted of a couple of words from the tournament organizers and the roll call of all the winners of the main event, the Warhammer tournament:

1st place: Roko Nikoljæ

2nd place: Rok Martinc

3rd place: Filip Berecka

Best Painted Army: Mario Ogrizek-Tomaš

Best Sportsmanship: Mislav Gorupec

Here's a short statement from Mario Ogrizek-Tomaš, the Best Painted Army award winner:

*"It took about two months to paint my Khemri army. I went for a striking red-green-gold colour scheme, which I am really satisfied with. While the skeletons are over ten years old, the army looks magnificent. I also used pigments and crackle effect extensively on the bases. My two favourite pieces are certainly the prancing sphinx and the tomb king carried by his guard (symbolising a casket of souls).*

*I would like to thank "UMS Agram" for organising this annual event! I really enjoyed it and hope to attend next year's as well!"*



Sponsors of Agram Arena Winter 2013 were: Carta Magica, Micro Art Studio, Kabuki Models, Art Zumber, Kerr & King, Ravnice Youth Hostel, Croatian Ministry of Defense and Zagreb Community of Technical Culture.

UMS "Agram" would like to thank all the sponsors of this event, most notably Kabuki Models who were kind enough to provide us with the main prize for the Best Painted Army Award at the Warhammer tournament and Micro Art Studio who are our long time sponsor providing us with loads of their cool resin bases.

With all the best from UMS "Agram" for the new year! See you in 2014!

# ARCWORLDE

## Sculpting Tutorial Part 2

By **Alex Huntley**



Hello there guys! My name is Alex Huntley – student, maverick and gentleman.

As I write to you now from my student grotto in the majestic city of Nottingham in the United Kingdom, I predict that you are wondering who the bloody hell I am! Well, if you hadn't already read my previous article in FPM Issue 7, I am the founder of Warploque Miniatures – a new British company specialising in unique fantasy wargaming figures.

After nervously handing in my last article to be fiendishly picked apart by those much better at spelling and grammar than I, I never really thought I would get a chance to write part 2 of my article, especially after that “greybeard” comment! However, the gods have indeed smiled upon me, as once more the editor of FPM asked me to write for this most prestigious of e-publications. Obviously I must have done something right!

What we have covered so far.

If you were unfortunate enough to read my previous article, you will know at what stage we had left off before now. For those who haven't, here is a quick summary of the story so far.

On the 1st of August I launched a Kickstarter campaign (oh the horror!) to help fund the release of my first ever table top wargame, [ArcWorlde](#). ArcWorlde is a 32mm fantasy skirmish game, set in the eponymous realm of ArcWorlde, with the entire figure range designed and sculpted by yours truly.

Throughout the course of these two articles, I have been sculpting one of the six “Promo Models” from my Kickstarter campaign. As I released six initial warbands for ArcWorlde, I therefore decided to create a character for each race. These miniatures would only be available during the Kickstarter and at select trade fairs I attend myself and were a way to really experiment and have fun with the races I had created. It can be rather a long slog sculpting an entire Kickstarter's worth of miniatures by yourself, as well as studying for a degree, so I wanted some fun models that people would love and that I would love making.

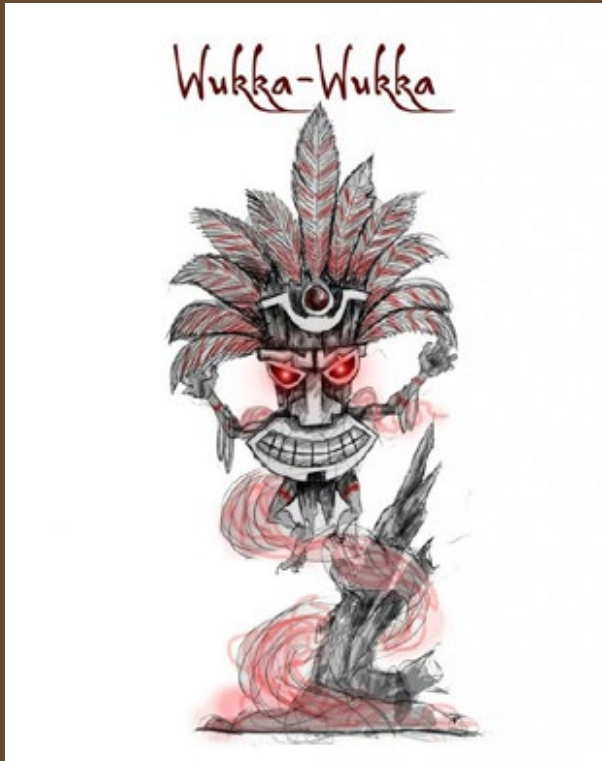

Past the Bayourk tribes of the Cayjon Swamp-lands, lie the sweltering jungles of Chaq-Itza. ArcWorld's largest continent, the vast majority of Chaq-Itza remains unexplored and unconquered. The north of the continent is covered in thick, impenetrable jungle, with huge trees and countless species of animals and plants.

There lurk the Jungle Gremlins!

Thought to be closely related to the diminutive Boglins that dwell in the Cayjon Swamplands, the Gremlin is a stunted creature, humanoid in shape, but with skin varying in hue from muddy brown to vivid green. This makes them nigh impossible to see in the thick vegetation and usually the only warning of a Gremlin attack is the sound of wardrums and chattering voices.

More cunning and ferocious than their northern cousins, they dwell in vast tribes, using their superior numbers when hunting to bring down even the mightiest of creatures.

Jungle Gremlins will eat just about anything and wear the skulls and hides of their prey with pride. It is thought that many exploration parties have met their fate at the hands of these cannibals, as it is not uncommon to see human bones amongst their grisly trophies."

The miniature I have been sculpting for you fine people is the last on my list of Promo Models, "Wukka Wukka" — a character from the Jungle Gremlins of Chaq Itza warband.

The character known as Wukka-Wukka is a powerful, but mysterious entity known throughout the Gremlin tribes of Chaq-Itza. It is said that he takes the form of a gigantic, wooden mask, adorned with feathers and other trinkets. When unworn he lies dormant, but when placed upon the head the spirit of Wukka-Wukka invades and takes over the unfortunate wearer, their body his to command!



The Model So Far

In the last article, I talked about my tools, my putty and the various techniques and processes to get the miniature up to this point. The main body of the...well, body, has been completed, the armature suitable sturdy and everything is in place to start work on the really fun bits – the details!

In part 2 of this article, I will be showing and explaining a few tips and techniques that I use to build up the detail on Wukka-Wukka, hopefully bringing him to completion. I will admit now that I am far from the most talented sculptor in the world, or the best teacher in the world, but hopefully my awkward fumbblings at the keyboard may, if not enlighten you, at least entertain you.

Starting work on the details.

Now, if you look at the concept art for Wukka-Wukka, there is a distinct possibility that you may notice the fact he is wearing a ruddy great mask (well, technically he IS the mask, but let's not get too bogged down with details here). The face is always the focal point on any humanoid miniature and is for me the most fun bit to sculpt. He might not have the most conventional of features, but the same focus applies.



Mask

When sculpting a large, flat area, such as a mask, a weapon or a shield, I often make it separate to the main miniature. Not only does it make it easier to work on, it also means you can work on it when the rest of the miniature is drying and vice-versa. Stuff like this saves a heck of a lot of time – very important when you have a whole Kickstarter’s worth of models to sculpt by yourself!

When starting the mask, I rolled a 50/50 mixture of Green Stuff and Magic Sculpt, laying a thin section on a sheet of clear plastic. The smooth surface of the plastic keeps the mask flat and also makes it easy to remove the sculpt once it is finished. Any smooth plastic will do, though I have found that the clear casing on blister packs works pretty well!

Whilst the putty was still soft, I shaped the mask using my trusty craft knife. The odd looking mushroom shape that was the fruit of my labours will form the wooden head of the mask, as well as the feathery plumage. At this point, I will be just concentrating on the face of the mask, but fear not! Those feathers will come later...ooh!

Next, I started working on the wooden body of the mask. Wood is a really easy and a very effective texture to sculpt and can add lots of interesting surfaces for painters. Maybe I am biased because I grew up in an old farmhouse covered in wooden beams and surfaces, but wood just makes everything look better!

First off, start by scoring lines down the area you want to be “woodified” (that’s not even a word I know) that are equidistant from one another. These will form the wooden planks that the mask was constructed out of.

Next, score random lines down each of the planks, interspersed with oval-like shapes. This will be the basis of the wood grain, with the knots included. Don’t worry about how neat or regular the lines are, the rougher the better! Of course, if you are doing smooth wooden panels, such as a gentleman’s polished oak writing desk, then maybe don’t press as hard into the putty. On the other hand, if you are sculpting the rough-hewn door of an ogre’s privy, then you

can afford to be a bit more vigorous with your tool!

My final step isn’t necessary at all, but can add character to your miniature and, of course give more interesting surfaces for the painter to exploit. Taking my craft knife, I pressed lightly on areas of the wood and took little notches out of the sides of the panels. The resulting nicks and scratches give the wood a battered and well-used appearance.

This easy technique can also be used to create the gnarled bark of trees and logs. Just follow the same steps, but don’t divide the area up into planks this time. Unless you want to... don’t let me tell you what to do, you do whatever you want! YOU LIVE YOUR LIFE! \*ahem\*.

### The Mask Details



Once the putty has cured, I sculpted the facial features on top. As these surfaces are rather angular, rather than organic, I used my craft knife to carve some areas after the second layer of putty had dried. The electric engraving tool (see previous article) can also come in handy for some of these bits!



Now that the face of the mask has been completed, it's time to work on the feathers! Now, feathers are notoriously a pain in the neck to sculpt, especially if there are a lot of them, but I think I've come up with a technique that is easy and quick! I'm glad I did... far too many of my miniatures have feathers on them for me to try any other way and keep my sanity intact!

First, lay a sausage of putty on the flat surface that you prepared beforehand. When making overlapping feathers, it's important to sculpt the underlying ones first, as it can be a real pain to do it the other way round!

Next, take your craft knife and press it flat on either side of the sausage, leaving a thin ridge of un-pressed putty in the centre. This will form the quill and the flat areas will be the fronds of the feather. If the splodging of the putty has left you with an undesirable shape, then use this opportunity to trim the edges to your satisfaction.

Finally, use your finest sculpting tool to score thin lines down each side of the feather, forming stacked "V"s running along the length. If you wish, you can use the same sculpting tool to separate a few fronds to add more interesting details to the miniature, though this of course isn't required.

After doing this for all of the feathers on the head-dress, the front of the mask is now complete! After waiting for it to dry, I separated the sculpt from the plastic with a cheeky wiggle of the craft knife and stuck it on the main miniature with a blob of superglue. Now that the mask is free of the plastic, I sculpted the back of the mask using the same techniques.

### The Hands

Now that the mask is finished, it's time to look at the rest of the details on the miniature. I decided the most logical part to work on next would be the hands, though my logic is almost always flawed. To be honest, it really doesn't matter what order you sculpt the

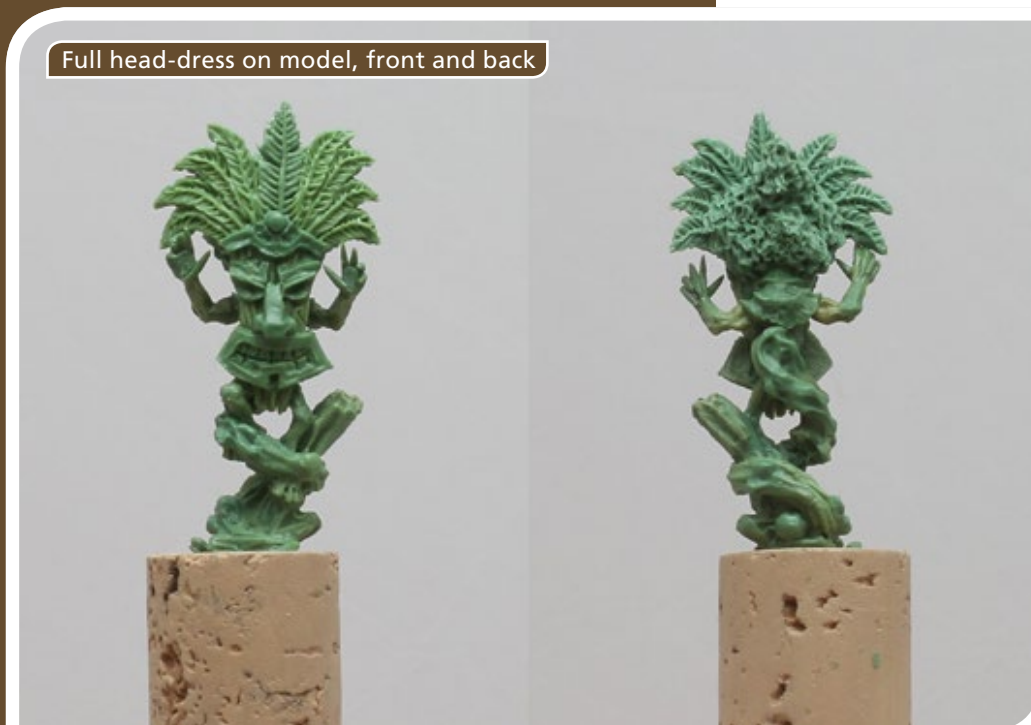



details at this stage – just go with whatever feels right!

If you remember from the first instalment, I constructed the base of the hands using a number of Green Stuff sausages to make the fingers. Now that these are very much dry (one of the benefits of leaving a sculpt for a few weeks...), place a tiny sausage of putty horizontally across the area where the fingers join the palm, another half way down the fingers and another three-quarters of the way down. These will form the knuckles and joints of the hand.

Use your tool, in this case I used the silicone one, to blend the sausages into the Green-Stuff fingers. Then, use your finest tool to separate out the fingers and the knuckles. After this has been done, revert back to your previous tool to smooth those cuts and make them look more organic.

Now you have your hand! It is at this point that you may choose to add fingernails to your hand. Usually for 28mm/32mm scale, most sculptors leave this part out for anything human-sized or smaller. However, if you are a crazy French sculptor, you can add not just the fingernails, but the muck underneath the fingernails and the hair on the knuckles too...damn them.

### The Bones and Trinkets

Now that all of the essential components of the miniature have been completed, all that remains is to jazz things up a bit with some gubbins! I always find these last few additions to a model the most enjoyable and can really add a lot of character to a sculpt. They can also be the fiddliest too, so be careful, fellow sculptors!







The Finished Miniature



The Finished Miniature

As Wukka-Wukka is a shaman from the jungles of Chaq-Itza, I have given him some rough and grisly trophies to proclaim to the world about his 'orrible 'appenings. As the mask takes up most of the room on the miniatures. however, I have been selective about the amount of trophies and where to put them.

First of all, I gave him some bangles to drape around his wrists. If I had a soft enough wire, I would have used that to create the bangles, but as I did not I just used putty. If you are sculpting to cast, make sure you fill any gaps that might be made by dangling jewellery – your caster will not thank you for that!

Next, I gave him some bones around a rough loincloth and scattered some across his base. Everyone knows you can't have a decent wargaming figure without skullz, but I've tried to keep things to a tasteful minimum. It is all too easy to go overboard...

And with that, Wukka-Wukka is finished! Not only is he finished, but he's ready and eager to lead the ferocious Jungle Gremlins into battle against all and sundry, the cheeky little critter.

I hope that you have enjoyed your journey through the exciting process of creating a wargaming miniature and that my half-witted ramblings have inspired you to try it out yourself. If a snotty 20 year old from Yorkshire can do it, then you can too! There is nothing quite like seeing an idea that you have conceived being brought to life in front of you and it really is addictive. Next thing you know, you'll be up to your armpits in Green Stuff, surrounded by hundreds of sculpts and wondering where your social life went...or was that just me?

Thanks for reading and good luck with any and all of your future endeavours!

Cheers, Alex Huntley

By Tim Fitch



# QUESTIONS?

Welcome to a new feature for Figure Painter Magazine, "Questions, Questions, Questions". Its a simple format; a prominent member of the hobby is sent some questions regarding their involvement, thoughts and experiences. They can then answer as much or as little as they wish to any number of the questions.



*To start off, we have someone rather special. Mr. Jean Bey, who many of you will know as the creator and driving force behind Rackham miniatures and the Confrontation skirmish game.*

1. For many people, you'll always be known as the driving force behind Rackham. What was your motivation for starting the company?

A beautiful object always tells a story. I've always loved writing fantastic stories, then drawing elements from these universes. I have always been fascinated by the evocative strength of some objects. An object is the means through which the story becomes palpable, through which something completely imaginary becomes concrete. The simplest way to achieve this and realize my dreams was to create my own company. To be sure that the craziest creative aspects will be able to run wild and to share this passion for figures with as many people as possible.



Arthur Rackham — The Rescue — 1905



2. You have a background in design. How did this influence the distinctive character of Rackham miniatures?

I'm self-taught. I learnt by studying the works of artists who inspired me and made me dream all these years, such as Gustave Doré, Arthur Rackham (*Alice in Wonderland*), Alan Lee, Brian Froud (who created the designs of the *Dark Crystal* movie), Hayao Miyazaki and Yoshitaka Amano. These artists had in common a very strong sensitivity and an ability to create incredible and extraordinary characters with a powerful sense of details.

What strikes me in the art of Arthur Rackham, the illustrator of tales and stories of the imaginary, is the strength of his stroke, his modernity, his ability to shape the material of his characters with great curves and finesse. It is to pay tribute to this artist that I decided to name the company after him: Rackham.

3. Did you expect them to be as initially successful as they were?

We always hope to get a lot of success, but right then you don't really know what to expect. It is meeting with the players that truly tell us that what we are doing is good or not. Success is mainly about knowing that on the other side of the world someone appreciates what you've done; it's the pleasure they have to discover something new, the pleasure they have to play with something you share with them. I have often been touched by the people I could meet



in stores, at shows and during conventions or tournaments. I have been a player and a miniature collector since I was a kid. To be able to exchange and share this energy and this passion, directly and without any filters with players, is very gratifying. It's this kind of exchange that gives you the energy to do the best on a long run.

4. It's been said Rackham has been the only credible threat to Games Workshop over the past 20 years. Did you see them as direct competition?

I wouldn't say that, because what we did couldn't really be compared to what Games Workshop does. I wanted to bring a different vision to the miniature players, where each player could appreciate with the same pleasure, regardless of the number of miniatures he owned. That is why each and every miniature benefited from the same attention to quality, the same will to create each figure to be unique. It is with this vision that Rackham and Confrontation were created.

5. What would you put the continuing success of Confrontation down to?

As long as I was able to decide about the design of each model and everything that was related to the universe of Confrontation, there was no compromise made on quality. Today, it is again the case with the new universe, the game and the figures I've been working on during the last few years.

6. Was managing a company and being its creative director more demanding than you thought it would be?

It could be difficult, but I think it was mainly an asset. It is what allowed me to be free to make decisions that made the originality and the strength of Confrontation. For example, to make the choice back then to do a skirmishes game at the very beginning rather than a mass battle game or a new way of playing with miniatures by using cards with stats which replaced rule books. The fact that the Confrontation rule booklet was included for free in all blisters was a creative director's idea and an entrepreneur's decision.

I've always assumed the decision to launch a figure only if it was at the right level of quality. Giving more time to do the things as they needed to be done. Of course, it's not always something very easy to tell to people who work days on something difficult

that their work isn't finished enough and that they need to continue until it's done. But it's the only way to push the limits, to create something visually stronger; something really unique.

It is this intention which is given to the artist and which passes down to the sculptor. An object must be enjoyable from any angle. Everything must be visible, credible and living. These are the essential notions to create figures that will have a real evocative strength, from the starting intention to the moment when the player will take the miniature in his hand.

7. What was a typical day like for you as head of Rackham miniatures?

It depends on the period; at any point in time, I would start my day by saying hello to everyone, from the stock room to the artists, but always lingering in the foundry. There was a station for pre-production dedicated to prototypes and I would always spend some time there 😊



8. When did you start to feel the company was slipping away from you?

The demand was so great that investments became heavier and heavier to be able to answer expectations in a right and durable way. When you work in the game industry, banks do not take you seriously...I was forced to open the capital to investors, which opened the way for financial choices drifting away from my artistic choices.

9. Do you think the early success of the company proved to be its undoing later on, in effect it growing too quickly?

I spent three years designing and creating what was to become Confrontation and Rackham, from 1995 to late 1997. Less than a year after the launch of Confrontation, the game had been awarded "Best of Show" at the Lucca Games Show at the end of 1998. Confrontation quickly became a standard in the miniatures market. From 1998 to 2007 the Rackham studio achieved great success continuously and was recognized everywhere for the quality and the originality of its game universe and its miniatures. It's only after these twelve

years that the financial imperatives took a place that outgrew what I had wished for.

10. What was that final day like when you had to leave your position as CEO?

Initially, I decided to accept leaving my position as CEO on the condition I would be able to continue to take charge of all the creative aspects. It was the initial deal, but during this period I understood that it was just a matter of time before people in charge would change the deal, to take full control of all aspects of the company even if they don't know anything about miniatures and games! Sincerely, it was terrible...this period lasted more than a year and until the end was the most horrible days of my life.

I also understood that it was just a matter of time before I would be fired from the company I created more than 12 years ago...

11. Did you feel the new majority share owner would take the company forward in its original direction?

I created Rackham to do the best possible figures, associated with a great game universe. The investors found financial reasons in this but had a different approach. I hoped we could keep a agreeable course for Rackham, but the financial choices were the strongest.

12. Was the decision to go over to pre-painted plastic miniatures one you agreed with?

I really wanted to work on unpainted plastic figures because this allowed us to offer miniatures with more volume, delivered with several variations without additional cost for the players and with an incredible quality, like the Aberration Prime which I am very proud of.

We worked for a long time to achieve an irreproachable plastic quality and I think we attained it. Plastic figures allowed cheaper pieces for the players compared with their counterpart in metal. Going to pre-painted plastic was valid as long as an unpainted option (both metal and plastic) still existed for the players wanting to paint their own figures. Ceasing to produce the metal Confrontation line was not my will, but at that moment the decision was not mine to make anymore and I had an obligation to support it.

13. What prompted you to finally leave the company altogether?

What prompted me to leave the company was when the new owners made the decision to destroy all our metal moulds, to show to all the Rackham staff members that Rackham was no longer Rackham, but a new company with new



leaders and a new direction! I spent my last year and half at Rackham with nothing to do; not being allowed to make a single decision (especially artistic decisions) directly or not, on the games and miniatures I created and witnessing Rackham moving away from all the values on which I had created the company. I suffered a lot from this, but now it is far behind and I am completely turned towards the future.

14. Rackham miniatures are still available from numerous online outlets. Do you know who owns the rights to these?

Anything that is done today around the Rackham miniatures and the Confrontation licence, Cadwallon, AT-43, etc... is done without me. Currently I have no rights, neither artistic nor financial.

15. Your miniatures and the Rackham style are still very much sought after. Have you every thought about starting another miniature company, perhaps on a smaller, more boutique scale this time?

Things have changed a lot in the way of making a project. For instance, today crowdfunding enables one to speak directly to the players and for the players. I see the positive input it brings the the field of miniatures and games.

16. What Rackham product are you most proud of?

Shanys the Shadow, the Red Dragon, the Aberration Prime, Isabeau, the Wyrms Dirz and the Scavengers of Acheron, The Ophidian miniatures also, the first Griffin Inquisitor, Aldenyss the Silent, Ejhin De Vanth, Kayl Kartan, Arkheon Sanath, the Watcher and the Prowler Wolfen, Killyox, the Horned Raiders and so many more. I like a lot of



them, they speak about so many different stories and adventures in my mind, but I truly hope to be able to surprise everyone in the coming weeks...

17. Do you keep in contact with any of your old Rackham colleagues?

Yes, most of the sculptors and painters. Paul Bonner became a close friend too.

18. How would you like to be remembered?

I'm not dead yet! 😊

Whatever happens, I hope that my will to share my passion for figures will live on in the spirit of the players. I created a new company: Hanakai Studio and a new universe, a totally new way to play with miniatures and I will soon unveil my new game and figures for you.

I'd like to thank Jean for his time and effort in answering the questions I put to him. It looks like something good is in the pipeline from the talented Mr. Bey.



# **WIN** A Free Plinth Every Month

With **FIGURE PAINTER** magazine

Simply upload an image of your painted miniature to our facebook page and the miniature with the most likes in one month wins a free display plinth from Model Display Products.



courtesy of

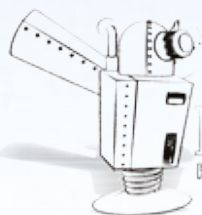

Robot Pigeon  
PUBLISHING

[www.modeldisplayproducts.com](http://www.modeldisplayproducts.com)





Obi-Wan Kenobi by  
Pavel Michal



Orc warrior in heavy armour by  
Andrey Demidov



Cultists of Sect Tetchvar by  
Sergey Chasnyk



The Phoenix and the Gorgon  
by Lil Legend Studio





Dwarf Lord by  
Klim Vladimirovich Kustarnikov



The Serpent & The Eagle by Lil Legend Studio



Leman Russ by  
Miniature paintings by Juan



By Zoe Wolf



Sanguinary Guards by Kenrick Hatton

Black Legion Contemptor Dreadnought  
by Lil Legend Studio



By Nathan Pullen



Chaos Chosen Space Marine by Łukasz Zulus Mazur

Night Lords Giant Brass Scorpion by Shane White

Confrontation Phoenix by  
The Painting Dojo





# Firestorm Games



Firestorm Games is an Independent Wargames Retailer in Cardiff, South Wales. As well as the webstore, we have our own bricks and mortar store, a short walk from Cardiff City Centre.

Attached to the store is our gaming area known as 'the Battlefields' which consists of over 35 6"x4" gaming tables, full of scenery for your pleasure! We are open late nights on Tuesday and Thursday and attract a large mix of people ready to play whatever takes your fancy! The Battlefields now also has a fully licensed 'Khador themed' bar, great when playing a casual game against your mates or in one of our regular tournaments or events.

## Firestorm Games Ltd

8A Trade Street, Penarth Road  
Cardiff, United Kingdom  
CF10 5DT.

Tel: **02920 227117**

**[www.firestormgames.co.uk](http://www.firestormgames.co.uk)**

**Firestorm Games**  
[www.firestormgames.co.uk](http://www.firestormgames.co.uk)  
Tel 02920 227117

**Up to 15% off RRP**  
With Free Worldwide shipping on orders  
over £30!

