

ABANDONED ARTS PRESENTS: FEATS OF DESTRUCTION

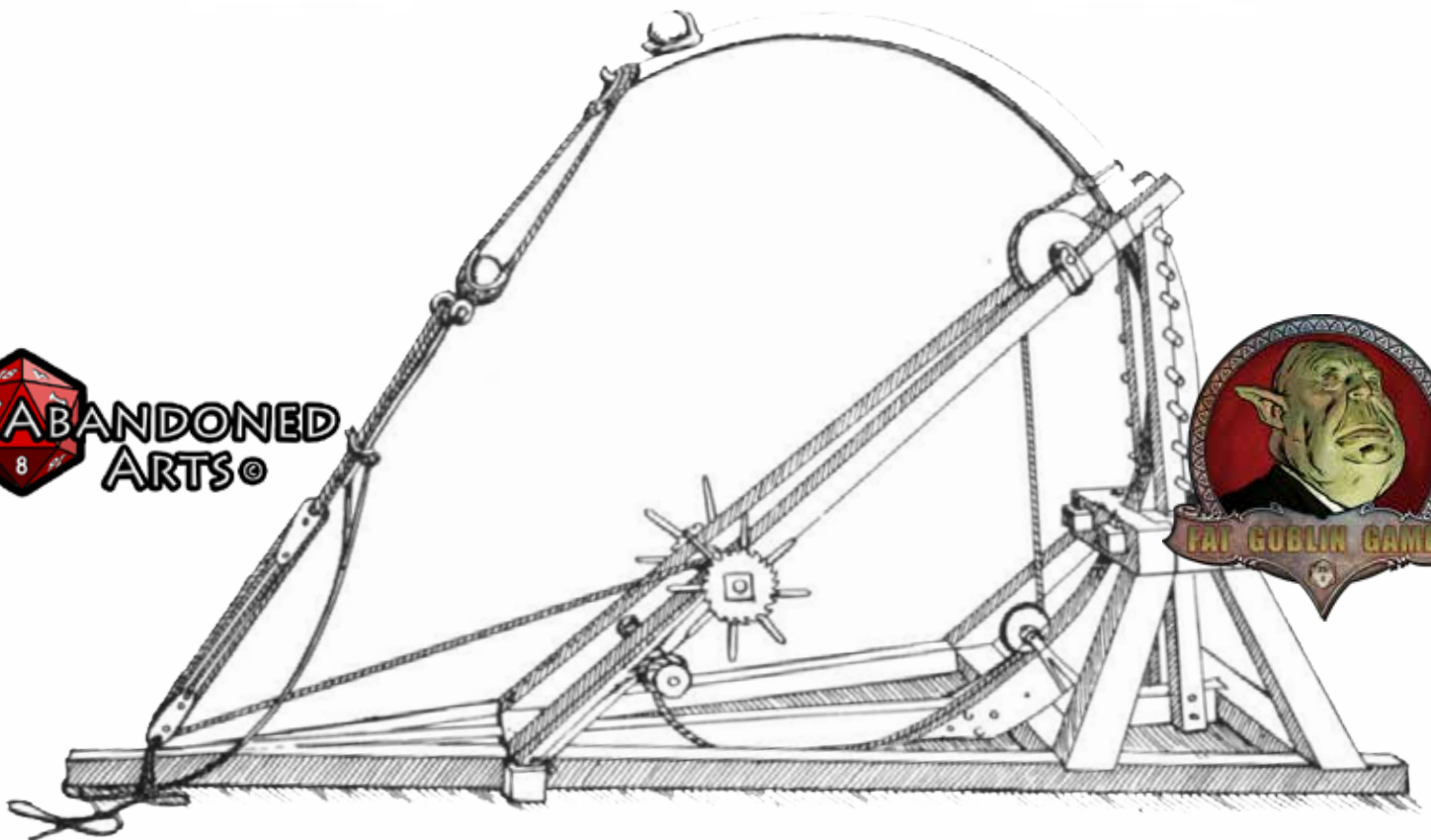

TWELVE NEW FEATS FOR USE WITH THE **PATHFINDER**[®] ROLEPLAYING GAME

[Facebook](#)

[Tumblr](#)

[Twitter](#)



Compatibility with the Pathfinder Roleplaying Game requires the Pathfinder Roleplaying Game from Paizo Publishing, LLC. See <http://paizo.com/pathfinderRPG> for more information on the Pathfinder Roleplaying Game. Paizo Publishing, LLC does not guarantee compatibility, and does not endorse this product. Pathfinder is a registered trademark of Paizo Publishing, LLC, and the Pathfinder Roleplaying Game and the Pathfinder Roleplaying Game Compatibility Logo are trademarks of Paizo Publishing, LLC, and are used under the Pathfinder Roleplaying Game Compatibility License. See <http://paizo.com/pathfinderRPG/compatibility> for more information on the compatibility license.

The More Feats! Line from Abandoned Arts

Each entry in the More Feats! product line contains a group of thematically-related feats for perfect for PCs and NPCs relevant to that theme. Feats of Destruction features feats for sappers, sunderers, and wreckers of havoc who want to add options to their actions.

BREACHING BURST [COMBAT]

You can smash an object with destructive force.

Prerequisites: Improved Sunder

Benefit: When you destroy an inanimate object with a melee attack, you may choose to deal damage to a creature adjacent to the object by showering it with splinters of debris and wreckage. The damage dealt is equal to one-half of the falling object damage that the object would deal after a 10-ft. fall. All damage dealt by this ability is piercing damage. Affected creatures are entitled to a DC 15 Reflex saving throw for half damage, as with falling object damage.

BREAKER

You have a knack for breaking things.

Prerequisites: Str 13

Benefit: You gain a +5 bonus on Strength checks made to overcome the break DCs of objects.

CONSTRUCT DEMOLITIONIST [COMBAT]

You can take down massive constructs with well-placed blows.

Prerequisites: Knowledge (engineering) 1 rank, Improved Sunder

Benefit: Constructs are not immune to death from massive damage from melee attacks that you make against them.

Normal: Constructs are immune to most effects that require a Fortitude saving throw, including death from massive damage.

CRUSH ARMOR [COMBAT]

You can sunder armor in such a way as to make it deeply uncomfortable to wear.

Prerequisites: Improved Sunder

Benefit: A shield or a suit of armor that you damage with a sunder attempt has its armor check penalty doubled until it is fully repaired. If the item gains the broken condition after receiving damage from your sunder attempt, the armor check penalty imposed by that condition is also doubled. These penalties stack.

DESTRUCTIVE CHARGE [COMBAT]

You can barrel through an intervening obstacle when charging.

Prerequisites: Improved Sunder

Benefit: You can attempt charge a space that you cannot reach due to an intervening object or obstacle. At any point during your charge, you may make a single melee attack or break check against an intervening object (like a door or a barrier). If you break or destroy the object, you may continue the charge unobstructed.

Normal: You cannot charge through an obstructed path.

DISMANTLER

You can dismantle obstacles systematically.

Prerequisites: Knowledge (engineering) 3 ranks

Benefit: As long as you have a crowbar, hammer, pickaxe, or a tool kit in hand, you can make a Knowledge (engineering) skill check in place of a Strength check when attempting to overcome the break DC of a door, container, or another hinged or mechanical object.

HEAVE-HO [COMBAT]

You are a dastardly adept of guerilla warfare.

Prerequisites: Str 15, Knowledge (engineering) 3 ranks

Benefit: You gain a +1 bonus on ranged touch attack rolls made to drop or push objects onto characters. A character that fails its Reflex saving throw against the falling object damage takes an additional 1d6 points of damage.

IMPROVED DESTRUCTIVE CHARGE [COMBAT]

You can smash through multiple obstacles when charging an opponent.

Prerequisites: Destructive Charge, Knowledge (engineering) 6 ranks

Benefit: You can attempt to use the Destructive Charge feat to break or smash your way through any number of intervening obstacles during a charge.

IMPROVED WRECKING BALL [COMBAT]

You leave a trail of destruction in your wake.

Prerequisites: Improved Sunder, Wrecking Ball, base attack bonus +3

Benefit: When you use your Wrecking Ball feat, you may combine the full attack with a move action, attacking any or all objects that come within your reach as you move.

ROUTINE MAINTENANCE

You take especially good care of your possessions.

Prerequisites: Knowledge (engineering) 1 rank

Benefit: Objects in your possession gain 1 additional point of hardness as long as you possess them (as long as they possessed at least 1 point of hardness to begin with).

TRAPFINDING EXPERT

You've got a keen eye for hidden dangers.

Prerequisites: trapfinding

Benefit: You can move at full speed while searching for traps and secret doors, taking no penalty on Perception checks to notice either type of object.

Normal: Searching characters move at half speed, or may take penalties on Perception checks for being distracted.

WRECKING BALL [COMBAT]

You can hastily wreak havoc on the environment.

Prerequisites: Improved Sunder

Benefit: When you use the full-attack action, you can give up your regular attacks and instead make one melee attack at your highest base attack bonus against any or all unattended objects within reach. You must make a separate attack roll against every such unattended object.

* See the *Pathfinder® Roleplaying Game: Ultimate Combat™* sourcebook for details.



OPEN GAME LICENSE Version 1.0a

The following text is the property of Wizards of the Coast, Inc. and is Copyright 2000 Wizards of the Coast, Inc ("Wizards"). All Rights Reserved.

1. Definitions: (a) "Contributors" means the copyright and/or trademark owners who have contributed Open Game Content; (b) "Derivative Material" means copyrighted material including derivative works and translations (including into other computer languages), potation, modification, correction, addition, extension, upgrade, improvement, compilation, abridgment or other form in which an existing work may be recast, transformed or adapted; (c) "Distribute" means to reproduce, license, rent, lease, sell, broadcast, publicly display, transmit or otherwise distribute; (d) "Open Game Content" means the game mechanic and includes the methods, procedures, processes and routines to the extent such content does not embody the Product Identity and is an enhancement over the prior art and any additional content clearly identified as Open Game Content by the Contributor, and means any work covered by this License, including translations and derivative works under copyright law, but specifically excludes Product Identity. (e) "Product Identity" means product and product line names, logos and identifying marks including trade dress; artifacts; creatures characters; stories, storylines, plots, thematic elements, dialogue, incidents, language, artwork, symbols, designs, depictions, likenesses, formats, poses, concepts, themes and graphic, photographic and other visual or audio representations; names and descriptions of characters, spells, enchantments, personalities, teams, personas, likenesses and special abilities; places, locations, environments, creatures, equipment, magical or supernatural abilities or effects, logos, symbols, or graphic designs; and any other trademark or registered trademark clearly identified as Product identity by the owner of the Product Identity, and which specifically excludes the Open Game Content; (f) "Trademark" means the logos, names, mark, sign, motto, designs that are used by a Contributor to identify itself or its products or the associated products contributed to the Open Game License by the Contributor (g) "Use", "Used" or "Using" means to use, Distribute, copy, edit, format, modify, translate and otherwise create Derivative Material of Open Game Content. (h) "You" or "Your" means the licensee in terms of this agreement.

2. The License: This License applies to any Open Game Content that contains a notice indicating that the Open Game Content may only be Used under and in terms of this License. You must affix such a notice to any Open Game Content that you Use. No terms may be added to or subtracted from this License except as described by the License itself. No other terms or conditions may be applied to any Open Game Content distributed using this License.

3. Offer and Acceptance: By Using the Open Game Content You indicate Your acceptance of the terms of this License.

4. Grant and Consideration: In consideration for agreeing to use this License, the Contributors grant You a perpetual, worldwide, royalty-free, non-exclusive license with the exact terms of this License to Use, the Open Game Content.

5. Representation of Authority to Contribute: If You are contributing original material as Open Game Content, You represent that Your Contributions are Your original creation and/or You have sufficient rights to grant the rights conveyed by this License.

6. Notice of License Copyright: You must update the COPYRIGHT NOTICE portion of this License to include the exact text of the COPYRIGHT NOTICE of any Open Game Content You are copying, modifying or distributing, and You must add the title, the copyright date, and the copyright holder's name to the COPYRIGHT NOTICE of any original Open Game Content you Distribute.

7. Use of Product Identity: You agree not to Use any Product Identity, including as an indication as to compatibility, except as expressly licensed in another, independent Agreement with the owner of each element of that Product Identity. You agree not to indicate compatibility or co-adaptability with any Trademark or Registered Trademark in conjunction with a work containing Open Game Content except as expressly licensed in another, independent Agreement with the owner of such Trademark or Registered Trademark. The use of any Product Identity in Open Game Content does not constitute a challenge to the ownership of that Product Identity. The owner of any Product Identity used in Open Game Content shall retain all rights, title and interest in and to that Product Identity.

8. Identification: If you distribute Open Game Content You must clearly indicate which portions of the work that you are distributing are Open Game Content.

9. Updating the License: Wizards or its designated Agents may publish updated versions of this License. You may use any authorized version of this License to copy, modify and distribute any Open Game Content originally distributed under any version of this License.

10. Copy of this License: You MUST include a copy of this License with every copy of the Open Game Content You Distribute.

11. Use of Contributor Credits: You may not market or advertise the Open Game Content using the name of any Contributor unless You have written permission from the Contributor to do so.

12. Inability to Comply: If it is impossible for You to comply with any of the terms of this License with respect to some or all of the Open Game Content due to statute, judicial order, or governmental regulation then You may not Use any Open Game Material so affected.

13. Termination: This License will terminate automatically if You fail to comply with all terms herein and fail to cure such breach within 30 days of becoming aware of the breach. All sublicenses shall survive the termination of this License.

14. Reformation: If any provision of this License is held to be unenforceable, such provision shall be reformed only to the extent necessary to make it enforceable.

15. COPYRIGHT NOTICE Open Game License v 1.0 © 2000, Wizards of the Coast, Inc.; System Reference Document. © 2000, Wizards of the Coast, Inc.; Authors Jonathan Tweet, Monte Cook, Skip Williams, based on material by E. Gary Gygax and Dave Arneson.

Pathfinder Roleplaying Game Core Rulebook. © 2009, Paizo Publishing, LLC; Author: Jason Buhlman, based on material by Jonathan Tweet, Monte Cook, and Skip Williams.

Advanced Player's Guide. © 2010, Paizo Publishing, LLC; Author: Jason Buhlman, based on material by Jonathan Tweet, Monte Cook, and Skip Williams.

Pathfinder Roleplaying Game Ultimate Combat © 2011, Paizo Publishing, LLC; Authors: Dennis Baker, Jesse Benner, Benjamin Bruck, Jason Buhlman, Brian J. Cortijo, Jim Groves, Tim Hitchcock, Richard A. Hunt, Colin McComb, Jason Nelson, Tom Phillips, Patrick Renie, Sean K Reynolds, and Russ Taylor.

Pathfinder Roleplaying Game Ultimate Magic. © 2011, Paizo Publishing, LLC; Authors: Jason Buhlman, Tim Hitchcock, Colin McComb, Rob McCreary, Jason Nelson, Stephen Radney-MacFarland, Sean K Reynolds, Owen K.C. Stephens, and Russ Taylor.

The Book of Experimental Might. Copyright 2008, Monte J. Cook. All rights reserved.
Tome of Horrors. Copyright 2002, Necromancer Games, Inc.; Authors: Scott Greene, with Clark Peterson, Erica Balsley, Kevin Baase, Casey Christofferson, Lance Hawvermale, Travis Hawvermale, Patrick Lawinger, and Bill Webb; Based on original content from TSR.

Abandoned Arts Presents: More Feats! Feats of Destruction © 2016, Daron Woodson; Author: Daron Woodson, Layout by Troy Daniels, Art by Rick Hershey and Fat Goblin Games