

# IMPERIAL ARMOUR

## VOLUME FIVE THE SIEGE OF VRAKS - PART ONE

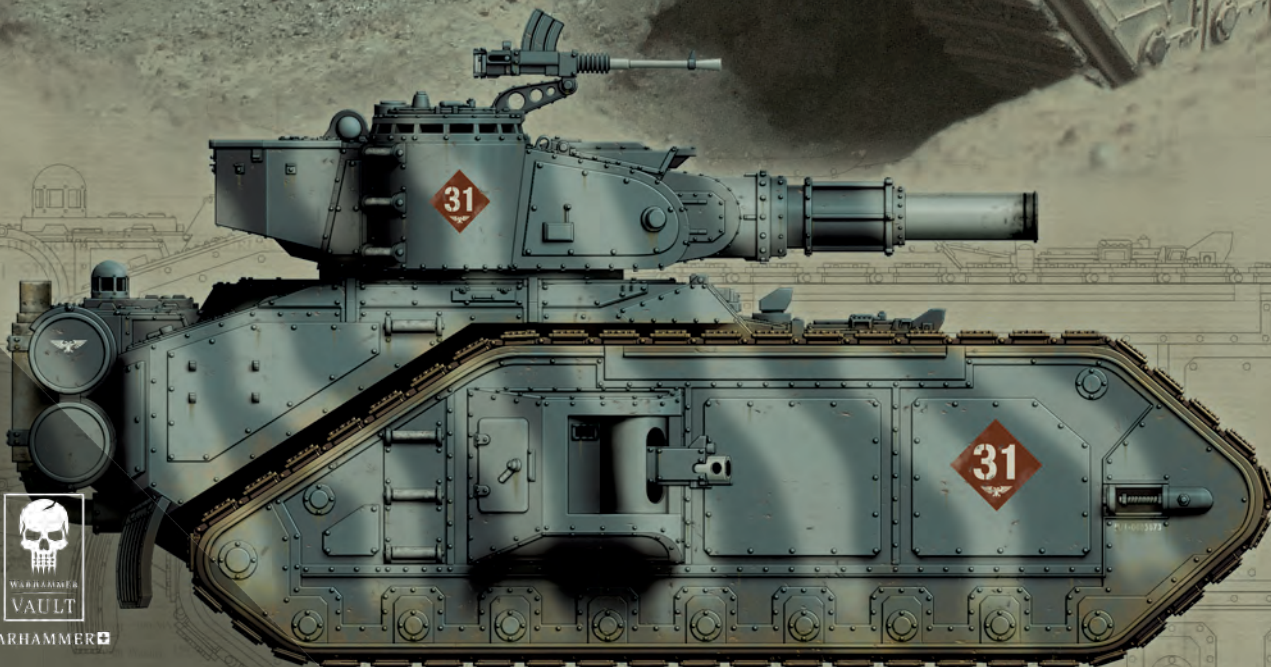

WARHAMMER

WARHAMMER  
40,000

EXPANSION

The Warhammer Vault exists to preserve the rich lore and background of Warhammer 40,000 and Warhammer Age of Sigmar. As such, outdated game scenarios and unit rules have been removed from this publication.

# IMPERIAL<sup>TM</sup>

# ARMOUR

## VOLUME FIVE

## THE SIEGE OF VRAKS – PART ONE

by Warwick Kinrade

**H**erein follows an examination of the most lamentable Siege of Vraks, bastion and armoury world of his most Divine Emperor, of the plans of those most treacherous and heretical rebels that led to its downfall and the glorious sacrifice of the Emperor's Imperial Guard in opposing the Intention and Works of the Dark Forces. Further examinations will be found into the grim and hardy regiments of Krieg, and those misguided Mortals who have unwittingly venerated the Powers of Chaos, at a terrible cost in blood, but worst still – to the eternal damnation of their own souls...

*"For Vraks we will give all in the name of the Death Korps. What others consider precious are as nought to us. Gladly we shall lay down our lives in the cause of our Emperor."*

Colonel Hamor, 261st Krieg Siege Regiment.

The Eye of Terror lies within Segmentum Obscurus. It is a cursed region of the galaxy where the laws of reality have collapsed, corrupted by the poison of Chaos as it seeps into the universe, creating a realm of unspeakable horror. Surrounded by the strongest and most unpredictable warp storms, the systems within the Eye contain the Daemon-worlds, planets at the whims of the Chaos Gods – planets of madness and insanity, where no mortal could venture and hope to escape with his mind or soul intact.

The Eye is a great cancer upon the galaxy, a rift in the physical universe through which warp space can flow. Slowly but inextricably it is expanding, a constant and growing threat to the Imperium and to all races in the galaxy. From within their fastness the worshippers of the Chaos Gods constantly seek to attack and weaken the Imperium. They are the Imperium's oldest and bitterest foes, the Traitor Legions, banished from the Imperium for their disloyalty during the Horus Heresy. They are the nine Space Marine Chapters of the First Founding that fought alongside the Warmaster Horus – and were defeated. After their defeat they escaped to the sanctuary of the Eye of Terror, and from there they have continued their war against the Imperium and its false Emperor. Worse still, they are not alone.

Throughout the Imperium there are many others who have turned to the worship of the Chaos Gods, some willingly, others enslaved against their will. Why? Because the human heart has always been weak. In seeking power, wealth and influence it is easily corrupted. For those willing to sell their soul and abandon themselves to the whims of Chaos, the Dark Powers offer a fast and easy route to real power. For the weak and dispossessed, or for those who pursue false and illusionary ideals, such as justice or freedom, the Chaos Gods provide a way of fighting back against a cruel and uncaring galaxy – a galaxy where each individual is just one amongst untold trillions. Of course, this itself is merely a lure, lies spread by those who seek to replace Imperium's worship of the Divine Emperor with the worship of their own Gods, and thus bring about the ultimate triumph of Chaos.

Few humans know the full extent of Chaos' power or its ultimate ambition. Only the Inquisitor-Lords of the Ordo Malleus or the Seers of the Eldar know the truth. That they are not just fighting for the survival of their race, but for the very nature of reality.

*"When the maelstrom descends, Vraks shall overflow with blood and skulls, and even the dead shall find no peace. Millions shall be sacrificed in their names, and the true Gods will rejoice... I have seen it, for I am the messiah of the coming apocalypse."*

Lord Xaphan, Apostate-Cardinal, Arch-Heretic and the Despot of Vraks.

## Credits

Written by .....	Warwick Kinrade
Digital Photography and Computer Images by .....	Tony Cottrell, Warwick Kinrade
Technical Line Drawings by .....	Chris Bristow, Paul Rudge, Dale Stringer Chris Catton, Tony Cottrell
Colour Profiles by .....	Paul Rudge, Warwick Kinrade, Tony Cottrell
Additional Background by .....	Alan Bligh
Production and Layout by .....	Warwick Kinrade, Paul Rudge
Krieg, Grenadier, Renegade and Ogryn art by .....	Karl Kopinski
Map by .....	Paul Rudge
Document Artwork by .....	Nuala Kinrade

## Acknowledgments

Forge World models designed by .....	Daren Parrwood, Will Hayes, Mark Bedford, Simon Egan, Daniel Cockersell, Tony Cottrell, Brian Fawcett
Terrain models designed by .....	Daren Parrwood, Mark Bedford
Terrain boards by .....	Mark Bedford, Daren Parrwood, Tony Cottrell
Models painted by .....	Mark Bedford, Owen Branham, Stuart McQuarrie, John Carter, Paul Rudge, Tony Cottrell Warwick Kinrade, Owen Rees.
Proof reading .....	Talima Fox, Stuart McQuarrie, Sandra Brassington, Alan Bligh.
Thanks to .....	The staff at Forge World and Games Workshop for their continued support, advice and encouragement. Everybody who e-mailed the Imperial Armour address with suggestions and feedback on our experimental rules.

### PRODUCED BY FORGE WORLD

First published in Great Britain in 2007 by Forge World, Games Workshop, Willow Road, Lenton, Nottingham, NG7 2WS.

This edition first published in Great Britain in 2010 by Forge World.

© The copyright in all text, artwork and images herein are the property of Games Workshop Limited 2010. All Rights Reserved.

Games Workshop, the Games Workshop logo, Citadel and the Citadel Castle, Warhammer, 'Eavy Metal, Forge World and the Forge World logo, Imperial Armour and all associated marks, logos, devices, names, characters, illustrations and images from the Warhammer and Warhammer 40,000 universe are ®, ™ and/or © Games Workshop Ltd 2000-2010, where applicable registered in the UK and other countries around the world. All Rights Reserved.

Product Code: 60040187005

Forge World Code: BK-PUB-B-010

British Cataloguing-in-Publication Data. A catalogue record of this book is available from the British Library.

ISBN: 978 1 84154 851 7

Printed in Great Britain

Games Workshop Web site:  
[www.games-workshop.com](http://www.games-workshop.com)  
Forge World Web site:  
[www.forgeworld.co.uk](http://www.forgeworld.co.uk)

## TABLE OF CONTENTS

### Section 1 – The Siege of Vraks

Vraks Planetary Survey. . . . .	5
Chapter 1. The Fall of Vraks. . . . .	7
Chapter 2. The Coming War. . . . .	10
Death Korps of Krieg Infantryman. . . . .	15
Chapter 3. The Killing Fields of Vraks. . . . .	17
Chapter 4. War of Attrition. . . . .	37
Vraksian Renegade Militiaman . . . . .	41
Chapter 5. The Angels of Caliban. . . . .	53
Chapter 6. Breakthrough. . . . .	67

### Section 2 – Forces of the Imperium

The Death Korps of Krieg . . . . .	85
Death Korps of Krieg Grenadier . . . . .	87
Krieg Uniforms. . . . .	91
Infantry Squad Organisation . . . . .	93
Heavy Weapons Squad Organisation . . . . .	95
Field Artillery Company Organisation . . . . .	97
Infantry Company Organisation . . . . .	99
Gorgon Assault Transport . . . . .	101
Centaur Carrier . . . . .	107
Field Artillery . . . . .	110
Heavy Artillery . . . . .	113
Leman Russ Annihilator . . . . .	116
Macharius . . . . .	121
The Dark Angels . . . . .	126

### Section 3 – Forces of Chaos

Ogryn Berserker . . . . .	137
---------------------------	-----

### Section 4 – Appendices

Krieg Colour Schemes . . . . .	141
--------------------------------	-----



# THE SIEGE OF VRAKS

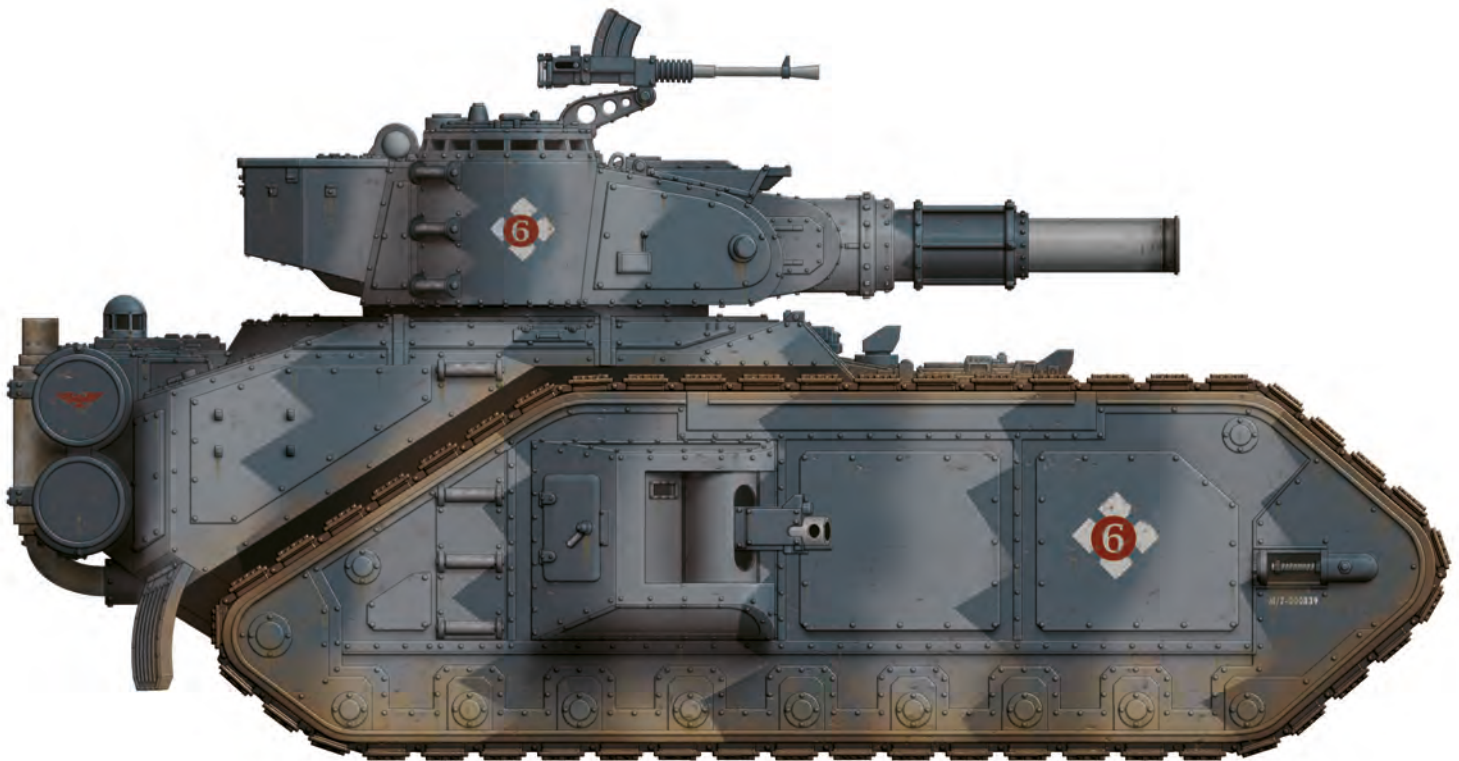

Macharius heavy tank of 6th Heavy company, 61st Tank regiment.

## VRAKS-PRIME – PLANETARY SURVEY

**Segmentum:** Obscurus.

**Sector:** Scarus.

**Sub-sector:** Kerak.

**System:** Vraks. Four planets (Prime, Secundus, Tertius and Uryx). One inhabited (Vraks Prime).

**Surveyed:** Unknown.

**Planets:** Inner Planets - Vraks Prime - post volcanic, temperate.

**Outer Planets:** Vraks Secundus - rock, no atmosphere.  
Vraks Tertius - rock, no atmosphere.  
Uryx - iceball, no atmosphere. Large asteroid trapped in Vraks' gravitational field.

**Satellites:** Vraks Prime - 0  
Vraks Secundus - 1  
Vraks Tertius - 1  
Uryx - 0

**Asteroids:** Outline asteroid fields - uncharted.

**Comets:** None known.

### VRAKS PRIME

**Summary:** Vraks is a Departmento Munitorum Armoury world. A vast storage facility for supplies and equipment mothballed for use by newly raised Imperial Guard regiments and as emergency war reserves.

**Size:** Equatorial Distance - 6,300 miles.

**Gravity:** 1.05 G

**Satellites:** None.

**Population:** 8 million (human and abhuman).

**Rotation Speed:** 1,100 mph.

**Orbit:** Mean orbital distance is 172 million kms from the star.

**Climate classification:** Temperate - standard (tempestuous).

**Mean Surface Temperature:** 11°C

**Tropospheric Composition:** Nitrogen 78.8%, Oxygen 19%, Argon 1%, Ozone 1%, Carbon Dioxide 0.1%, Sulphur 0.1%

**Tithe Grade:** Adeptus Non.

**Climatic Regions:** Polar Caps - Small northern and southern polar caps, perma-frost. Unexplored.

**Seas:** 55% of the planet's surface is covered by shallow, sulphur-rich seas. These provide the planet with an oxygenated atmosphere which is tainted by low-levels of sulphur, but native life has failed to evolve beyond single cell organisms, bacteria and algae-like life forms.

**Mountains/ Highlands:** Rugged, highly eroded highlands formed by tectonic movement. Some exposed deposits of harder igneous rocks are quarried for building purposes.

**Plains/lowlands:** Formed as volcanic lava fields. Flat areas exposed to weather erosion and crossed by canyons and trenches. The population are concentrated around the citadel and starport in the Van Meersland Wastes.

**Climatic phenomena:** Electrical storms.

The sulphur content in the upper troposphere, a legacy of Vraks' earlier volcanic period, creates conditions for sudden and severe electrical storms. Constant heavy cloud cover is blown by Vraks' prevailing winds, and increased particle friction creates immense energy that must be discharged through sudden and spectacular lightning storms. These are accompanied by heavy thunderclouds and massive precipitation, but last no more than an hour before

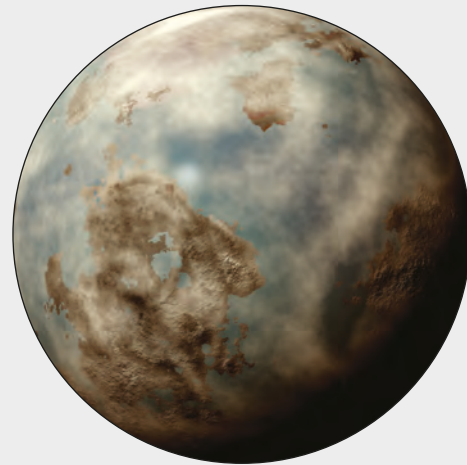

the storm has completely expended its energy. One or two such storms a day are not uncommon in most areas.

**Flora:** Some algae and single cell organisms have been noted. No further research has been undertaken.

**Fauna:** None known.

**Economy:** None. All import and export is regulated by Departmento Munitorum officials.

**Society:** As an Administratum facility, Vraks' society is organised with the same hierarchy as the Adeptus Administratum on Terra. Masters, Prefects, Adepts, Ordinates, Scribes, Ciphers, Curators, Menial and Subordinate workers run the vast bureaucracy on Vraks.

The millions of labour corp indentured workers are guarded by Departmento Munitorum garrison troops. Vraks' also has its own planetary defence force militia, organised from within the work force.

There is a substantial Ogryn population amongst the labour corps.

There is a transitory population of pilgrims visiting the shrine of St Leonis, ranging from approximately 1 million to 5 million. Exact figures are unknown.

Imperial Guard regiments arrive for arming and equipping before being transported to their next destination. Barracks are provided at the star port.

**Water Supply:** Deep hydro-sinks driven into the soft crust of the planet raise underground water, where it is filtered and treated for sulphur content before distribution.

**Principle Exports:** None.

**Principle Imports:** Munitions. Arms and weapons of all types. Foodstuff. Fuel. Manufactured goods.

**Food supply:** All food is supplied from off-world. Huge reserves of rations are stockpiled on Vraks, and a proportion of those are designated for use by the native work force.

**Urbanisation:** The largest urban area is the sprawl of worker hubs, temporary storage facilities, hangers, repair facilities, barracks and administration buildings that have risen up around the landing areas. Although still referred to as the star port, Vraks' star port is in fact a small city of some five million workers.

Other urbanised locations are the labour corps workers hubs, scattered across the Van Meersland Wastes to house the labourers that construct and maintain Vraks' network of storage bunkers, service roads and defences. These hab-zones contain rudimentary barracks as housing for workers and guards.

**Geological Composition:** Vraks' unusual geology has formed

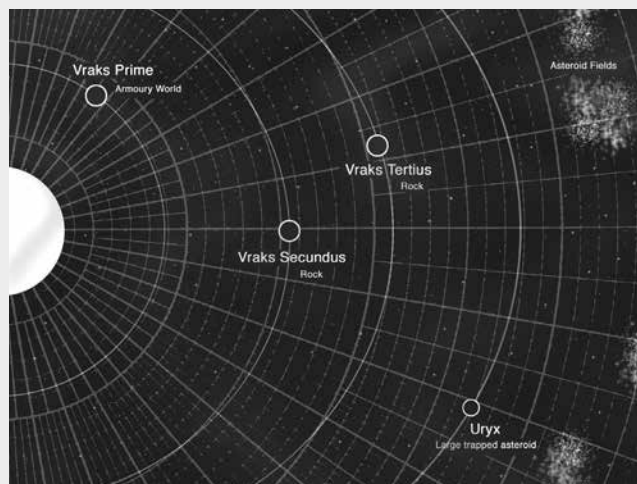

the planet's distinctive surface. Once, in the far distance past, the planet must have been a tumultuous volcanic world, with massive tectonic movement, seas of lava and tens of thousands of active volcanoes. The planet is now entirely dormant and stable, there are no active volcanoes and insignificant amounts of tectonic movement.

The planet's geology has created a surface of basalt-type rocks, which have been degraded through oxidation by the atmosphere. Erosion has reduced the surface to a combination of grey and yellowish dust and gravel, and soft crumbling pumice-like rocks. A high sulphur content has made the surface inhospitable to the development of native life, and requires the use of filtered breathing equipment by the population.

The planet's soft mantle is prone to rapid erosion, and rivers have been able to cut very deeply through the planet's surface. Over millions of years rivers have created a network of deep canyons, gorges and trenches, in places up to two miles deep. The nature of the surface geology means there is very little surface water, precipitation draining rapidly through the ground into large underground rivers. The collapse of these underground waterways helped create the sheer sided canyons and gorges.

**Tectonic Activity:** Vraks is now an old planet with a stable surface. In the distant past it was wracked by massive earthquakes and huge tectonic upheavals. These seismic shifts created the mountain ranges, and in places, large rifts where fault lines between two plates have collapsed to form deep abyssal trenches. Today the tectonic plates are stable, and very little tectonic movement has been recorded. This helped make Vraks a good prospect for subterranean storage of volatile materials, being easily quarried and stable.

**Known History:** As far back as Imperial archives record, Vraks has been an Administratum facility. Located in Segmentum Obscurus, to the galactic north-west of the Eye of the Terror, Vraks' importance lies in its strategic position as part of the Imperium's defences against attacks from the Eye of the Terror.

Vraks forms part of a network of Armoury worlds across Segmentum Obscurus used to stockpile arms and munitions for the Imperial Guard forces that would be needed in the event of a major incursion from the Eye of the Terror.

Forge worlds across the Imperium produce huge amounts of munitions, and these are often shipped to Armoury worlds, and placed into mothball storage until the Departmento Munitorum administrators require them. Where they are then removed from storage, until being shipped in huge quantities to the required war-zone or Imperial Guard regiment.

Vraks' location means it can quickly supply Imperial Guard forces committed to defend worlds close to the Eye of the Terror, especially in the Scarus sector. As such it forms a strategically important link in the chain of the Imperium's defences against major Chaos

incursions (such as a Black Crusade).

The Vraks system itself was first discovered and logged by forces expanding the new Imperium from Terra after the Age of Strife. Later it was explored by an expedition led by Rogue Trader Van Meer of the Van Meer household. A supply base was established to stockpile material used for future expeditions around the rim of the Eye of the Terror.

As the supply base grew in size the stockpiles needed protecting, and thus Vraks' uses as an Armoury world began in earnest. A fortress was built to protect the stockpiles from raiding pirates or aliens. A star port facility was constructed to allow easy access for freighters and transport vessels. These have all grown over time.

Great underground bunkers and hangars were constructed for the arms, ammunition, fuel, uniforms, etc, flowing onto the planet to be stored. The defences also had to be expanded. The more goods that were stored, the greater the risk of attack, so the greater the defences became. Over thousands of years Vraks has grown into a huge armoury. The spaceport has been expanded to service the largest Imperial landing craft, capable of ferrying huge shipments of arms, vehicles and munitions to the bulk carriers waiting in orbit. The Departmento Munitorum authorities control over the inward and outward movement of goods from their headquarters in the fortress.

The fortress of Vraks also includes the Basilica of St Leonis, built by Vraks' Cardinal-Astral in M.38 to attend to the faith of the millions of indentured workers interred on Vraks and consecrated with the bones of St Leonis (a missionary of the 38th Millennium who was martyred by heretics in the Scarus sector).

Pilgrims and penitents visiting the Shrine of St Leonis arrive by the thousand on Vraks, and are attended to by the many priests based at the Basilica of St Leonis and the attached Cardinal's palace.

**The Fortress of Vraks:** Situated in the centre of the Van Meersland Wastes, the citadel is the control centre of Departmento Munitorum operations on Vraks. It is a large fortress, situated atop the core of a long dead volcano. It contains the headquarters of the Planetary Defence Forces, the Master of the Administratum's offices, extensive archives, the Basilica of St Leonis, the Cardinal's palace and the Citadel's own garrison barracks. High security dungeons carved into the rock beneath the citadel itself are sometimes used as a secure prison for Inquisitorial prisoners captured in the sector. Astropathic communications, the Adeptus Arbites precinct, as well as the control centre for the network of defence laser batteries are also sited here.

As the nerve centre of the Armoury, the Citadel's defences have been constantly upgraded. Within the Departmento Munitorum it is now believed that Vraks is an impregnable fortress. Its walls are protected from orbital bombardment by void shield generators. It has an extensive curtain wall protecting it from direct assault. It is surrounded by a large network of defence laser batteries, making an assault from orbit suicidal for any star ship. These lasers can also be used against ground targets, and all approaches to the Citadel are covered by interlocking fields of fire. Three defence rings run for miles out into the wastes. These protect the storage bunkers from raiders and include trenches, defence lines, bunkers and strong points as well as pre-prepared artillery positions. The defence lines are further protected by lines of razorwire, tank traps and thousands of minefields. No army could assault Vraks and expect anything but deadlock and eventual annihilation.

In the event of a major attack, the Citadel's large garrison protects the citadel itself, whilst the planetary defence force militia, raised from the labour corps and given only basic training, are expected to man the static defence lines.

In the past Vraks has endured many raids, mainly from renegades and pirates seeking to loot equipment, and several uprisings within the labour force (see 4655082.M39 Vraks Uprising - Suppression of), but in 10,000 years Vraks has never fallen...

# CHAPTER ONE

## THE FALL OF VRAKS

*"The Scarus sector is a tinderbox – one spark may soon become a great conflagration. I shall light the fires."*

His Holiness Lord Xaphan, Cardinal-Astral Scarus

A world had gone silent.

The astropathic communications node on Vraks, where astropathic messages were gathered from across Scarus sector, checked, encrypted and re-routed by the cadre of astropaths that inhabited the tall censorium tower of Vraks' citadel, had stopped transmitting. The last transmission had been a garbled message, received by an Administratum office on Cadia. It was not an unusual event, astro-telepathic messages did not always make their way through the warp intact. The astropath's psychic-art was not a precise one. At first little attention was paid to a minor anomaly.

It would take the Master of the Departamento Munitorum many months to hear news of the disaster that had beset his Armoury world. Not until routine messages went unanswered would suspicions be aroused in the corridors of power of Segmentum Obscurus. Not until further investigations were undertaken, and the garbled final message was eventually forwarded to the Master of the Departamento's office on Terra would the truth be known.

Vraks had fallen. The impregnable fortress and its valuable stores were now in rebel hands. How could it have happened?

### **The Rise of Cardinal Xaphan**

At 366804M.41 Cardinal-Astral Borja died. He was a very old man. He was old beyond the comprehension of most mere mortals. His body had been kept alive for over four hundred years by the arcane arts of the Adeptus Mechanicus Biologis, with daily blood transfusions and the application of rare and expensive chemicals. Although frail he had endured to do the Emperor's work. His diocese mourned his passing. Bells tolled across the sub-sectors under his rule - although the old man had not left his Ecclesiastical palace on the Cardinal-world of San Artorus for the past two hundred years. Borja's seat upon the Holy Synod was now vacant, and a replacement had to be found. The eventual replacement was Cardinal Xaphan, a protégé of Borja's, whose rise through the ranks of the Adeptus Ministorum had been aided by his powerful patron. Xaphan was

enthroned into his new rank as the Cardinal-Astral Scarus on San Artorus, but before taking his place in the council chamber, the new Cardinal decided he would complete a pilgrimage. He would conduct a grand tour of his new diocese (for he had never seen the places he must now rule), and this pilgrimage would take in the many shrines and cathedrals of the Scarus sector. At each location he would preach the Imperial Creed and see that all was being done to protect the souls of the billions now under his charge.

The pilgrimage would take five years, and along with Cardinal Xaphan would travel his full entourage. A thousand preachers, deacons, chatelaines, servants and menials, along with a personal bodyguard of the Adeptus Sororitas. These warriors were a gift from the Abbess of the Artorus Priory of the Order of the Argent Shroud, to celebrate Xaphan's enthronement. It was a dangerous galaxy beyond the fringes of the Artorus system, and a Cardinal must be ready to protect himself and his flock with force as well as with faith.

The Cardinal's long pilgrimage took him to many worlds, where his very presence, as a chosen representative of the Emperor, whipped the faithful into a frenzy of devotion. Fanatical cults such as the Redeptionists attached themselves to his entourage. Xaphan's pilgrimage was a crusade they claimed, to rid the sector of heresy, to purge the impure and the unclean. He had been sent by the Emperor to do this holy work. Here was a man who could lead them.

On Thracian Primaris the Cardinal's sermons attracted tens of thousands of frateris. Rioting broke out just to catch a glimpse of the Cardinal himself. Hundreds died as the Sisters of Battle and local Adeptus Arbites forces fought to restore order. Thousands of faithful pledged themselves personally to the Cardinal's service. From world to world his entourage grew into a small army. The Cardinal's arrival had been like a spark that had ignited the fires of faith across the Scarus sector. Some extremists were even calling him a messiah.

Amongst all this fanatical devotion Cardinal Xaphan saw, perhaps for the first time, the true power that came with his new rank. On San Artorus there was much work to do, no doubt important work, but out here, amongst the lay people - the frateris, he was adored. His words could raise an army. Surely out here he could best do the Emperor's work. Back on the Cardinal world he would spend hours debating in the council chamber, signing declarations, attending long meetings with the Administratum offices. Out here he could take real action against the doubters and heretics that threaten the Emperor's divine rule.

Xaphan voiced his opinions to his advisors, in particular Deacon Mamon, a young man who had recently joined the Cardinal's advisors on Thracian Primaris. Favoured by the Cardinal as a practical man of action, and for his local knowledge, the Deacon encouraged the seeds that were already developing in Xaphan's mind. With a leader to unite the many cults of the Imperial creed, Xaphan's pilgrimage could become a war of faith across the sector. But Mamon advised his Cardinal that he must proceed very carefully. The Inquisition had spies and informers everywhere, and the Cardinal's movements would not go unnoticed by the notorious Ordo Hereticus. One false move and the Cardinal could be arrested for breaking the strict laws that governed the Ecclesiarchy. Most importantly, the Cardinal could personally command no men under arms. This ban had been enforced ever since the Age of Apostasy, when Cardinal Vandire had rebelled and his 'reign of blood' had almost shattered the Imperium. There would already be informers and disloyal traitors amongst his entourage. These were weak-willed individuals who lacked the Cardinal's clarity of vision and his holy purpose. These spies were in the pay of the Ordo Hereticus, and they stood in the way of the Cardinal's holy war. With Mamon whispering in his ear, it seemed that Xaphan could not trust anybody. The Cardinal needed an inner circle of trusted advisors around him – reliable men who could be vetted and kept under surveillance in return,

to safeguard their loyalty. The Cardinal must be very careful. If his desired war of faith was ever to come into being, he needed a safe, secluded planet on which to prepare and plan.

The place chosen by Deacon Mamon was Vraks. Vraks was a Departmento Munitorum Armoury world, a huge store house for war material, but it was also the site of the Basilica of Saint Leonis the Blind. Leonis had been a missionary, martyred in the 38th Millennia after having his eyes removed whilst spreading the word of the Emperor across the wilder systems of the Scarus sector. A shrine had been built to inter the saint's remains and relics. The Cardinal's pilgrimage should visit the shrine and take up residence in the palace attached to the Basilica. The palace already belonged to the Cardinal as part of the estates that accompanied his position. It was maintained by a skeleton staff in case he ever had need of it, but it was also the headquarters from which the Adeptus Ministorum oversaw the pilgrims that wished to visit the shrine.

The Cardinal left the details of the arrangements to his favoured Deacon, who had to request permission for the Cardinal to visit Vraks. The system itself was a highly sensitive location, and only those ships with permission could enter the system. The Departmento Munitorum had to be made aware that the Cardinal and his retinue would be arriving. The Imperial Navy needed to provide a vessel to transport the Cardinal, and an escort to protect him. All this was eventually done through official channels. The security formalities were completed and the staff of the Cardinal Palace on Vraks were sent into a frenzy of action when an astropathic message arrived saying the Cardinal-Astral would be taking up residence in under a month. Vraks would be the seat of the Cardinal's power in the Scarus sector until he was ready to resume his pilgrimage and begin his holy war.

### **The Cardinal on Vraks**

Xaphan's arrival on Vraks was a grand formal occasion, culminating with a procession to visit the bones of St Leonis the Blind in his shrine, led by the Cardinal himself with his entire entourage in ceremonial robes. Thousands of fanatical pilgrims followed in his wake. Xaphan approached the citadel along a road lined with the entire garrison in parade ground order. The Cardinal gave the usual blessing to the Emperor's servants on Vraks, met with the garrison commander and the

Departmento Munitorum Master-Prefect who ran Vraks' armoury, then, with the formalities complete, Xaphan retired to his palace with his closest advisors.

Few saw Cardinal Xaphan after those first meetings. He didn't make appearances in public, he sealed himself away within the palace, and only a selected few were allowed access to his Holiness. The running of the Departmento Munitorum armoury returned to normal. The pilgrims still came to file past the bones of St Leonis, the labour corps smashed and hauled rocks. The sisters of the Order of the Argent Shroud took up residence in the small priory attached to the Basilica of St Leonis and formed an honour guard to the revered saint's remains and relics. There seemed no reason for suspicion. But there was disloyalty and sedition breeding within the heart of Vraks.

Aided by Deacon Mamon, the Cardinal started to plan the first steps in his war of faith. Of course he would need a great army, although he already had its core with the followers that had sworn loyalty and service to him, it must be far larger still. Xaphan would need more men, and so his Deacon planned to circumvent the ancient ban on armed men in his service. The Cardinal could not command any forces, but in times of peril the Basilica of St Leonis the Blind could raise a *frateris militia* to protect itself. So, the Deacon's preachers and missionaries moved amongst the pilgrims and labour gangs preaching sermons that forecast that Vraks was under threat. Rumours abounded that heretical forces were already attacking neighbouring systems and that Vraks must be ready to defend itself. The preachers recruited *frateris militiamen* by the thousand, and soon the Basilica had a small army of men to defend it. The mood on Vraks became one of religious zealotry. Any who spoke out against the cardinal were demonised, some were arrested and dragged off to Vraks' dungeons. The Cardinal was the planet's saviour, the mob's messiah, and he would lead them all to salvation from the heretic forces that threatened them.

Simultaneously, Deacon Mamon was also busy establishing an inner circle around the Cardinal of fanatically loyal followers. Drawn from the many *frateris* who had sworn oaths of loyalty during his pilgrimage, or from the pilgrims already on Vraks, Mamon instructed the Cardinal's preachers to recruit what he called, the 'Disciples of Xaphan'. These would be the Cardinal's closest

supporters, men who he could trust and who would fight to the death for their master against any foe. Also into the inner circle were enticed the commanders of Vraks' garrison - the Steward of the Citadel and the high-ranking commanders of the Vraks' militia. Mamon saw the loyalty of these men as vital, and with the Cardinal's vast wealth he bought it. Where he failed to buy loyalty, Mamon soon had the leaders replaced, using the Cardinal's influence to install more amenable leaders. None of the forces these officers commanded were directly under the Cardinal's orders, so the ban had not been broken, but soon the commanders could be relied upon to do the Cardinal's bidding. In the coming holy war Xaphan would need their troops. *Frateris militia* served their purpose, but they were not replacements for a well-equipped and trained soldiery. The Cardinal soon had almost all of Vraks' military forces under his control. Only the *Adeptus Arbites* precinct remained outside his influence.

### **The assassination of Xaphan**

Whilst the Cardinal remained secretive, his gospel was spreading like wildfire amongst the repressed and hopeless of Vraks' labour gangs. These penal workers lived a wretched existence, building the underground storehouses, defences and road networks for the Departmento Munitorum. On Vraks there were millions of indentured workers, poor souls dressed in ragged overalls, chained together and under constant guard. Xaphan's preachers brought a message that gave them some hope - the Cardinal could redeem them of their crimes and allow them to join his coming crusade. There was hope of an escape from their brutal and short lives. That hope lit the fires of rebellion.

The Cardinal's message also reached other ears. Deacon Mamon had been right, the Inquisition did have many informers and news of his preachings alarmed the *Ordo Hereticus*. Theirs was a sacred duty to guard against heresy within the Imperial Cult, to monitor and police the Imperium against the enemy of corruption within. The *Ordo Hereticus* had seen it before - Cardinals whose personal power led them to stray from the Emperor's light. Powerful men who began to believe that they themselves could be worshipped like the Emperor. Decisive action had to be taken. Secret orders were issued to end Cardinal Xaphan's short reign.

The sniper-assassin had been lying in wait for his chance for many days. He had infiltrated the Citadel disguised

as a pilgrim visiting the relics of St Leonis and, under cover of darkness, avoided the guards and climbed to the highest tower above the basilica – from where he could see most of the Citadel grounds. And on a narrow ledge, camouflaged by his stealth suit, the sniper patiently awaited his chance to strike, carefully watching the Cardinal's palace, the movement of guards, the arriving guests and departing officials, for a clear shot.

A single shot rang out across the Citadel. The heavy penetrator round punched clean through a decorative pillar before hitting the Cardinal. In a bright flash of energy Xaphan fell backwards, but his rosarius-mounted refractor field had saved his life. His guards leapt to surround him, and two died instantly as accurate following shots took them clean through the head. Blood was splashed bright across the mosaic floor of the palace, but the sniper's one clear shot had failed. Quickly the sniper reloaded his rifle and jumped back through the thin vent that had allowed him access to the ledge. Inside the ancient tower it was dark and dusty. His mask compensated for the near darkness and he made for the narrow spiral staircase. He already had his escape route well planned and committed to memory.

Below, the courtyard of the Citadel was suddenly alive with panicking pilgrims and running guards. At the bottom of the stairway the sniper emerged through a narrow arched doorway. A young acolyte preacher stared in awe at the lithe black-clad figure. It was the last thing he saw as the Exitus rifle fired from the hip hit him through the chest. The assassin dodged away, but the pursuit was already on. Guards were rushing to seal off the Citadel and the Basilica. The assassin made for a side door, shot the lock away and kicked it open. There was no longer any need for stealth, just a headlong rush to escape – and death for anybody who got in his way. Rifle now discarded for extra speed, pistol in hand, the sniper ran, swift as his own speeding bullets down a dim high-vaulted corridor. Citadel guards were clattering in behind him. Firing blind over his shoulder two guards fell bleeding. The sniper dodged into a side alcove, and rapidly fired more pistol shells down the corridor to keep the guards back. From the far end of the corridor more guards appeared. Desperately the sniper looked for an alternative escape route.

Rolling across the corridor he found another sealed doorway, and blasted away the hinges. Beyond was an old

stairway down into the basilica's ancient vaults. He rushed down into the musty darkness, but into a dead end. Here lay the grim sarcophaguses of ancient holy men, as well as the scattered remains of the many pilgrims that had past away whilst visiting Vraks in passed centuries. The guards were soon coming down the steps behind him, and the first through the stairs' archway died to another well-aimed pistol shot. But the guards now had the assassin cornered. Nowhere left to run. Grenades were hurled in, and the mortuary chamber began to fill with dust and smoke. More grenades followed, then in rushed the guards, weapons blazing. His last two pistol shots killed two more guards before the cornered assassin died, riddled with bullets. His body was dragged up to the surface to parade before the faithful. Here was the traitor that had tried to kill Xaphan.

### **Uprising!**

Traitorous forces had struck at the Cardinal, attempted to kill their messiah, so spoke Xaphan's preachers. News of the assassination attempt sparked rioting in Vraks starport as the pilgrims ran amuck, fearing that the assassination attempt meant that the enemy forces long forecast were about to attack. The frateris militia raced to arm themselves and the guards of the armouries were ordered to stand aside and allow them in. The looters plundered weapons and ammunition in massive quantities. The Adeptus Arbites moved to re-impose order and found themselves in a pitched battle in the streets of Vraks' star port. They requested aid from the citadel garrison, but under Deacon Mamon's instructions received no help. The Arbites precinct house was soon besieged by an angry mob, and would hold out for several weeks before eventually being overrun.

It had started. The Cardinal was moving to take over Vraks and begin his crusade. Soon there was fighting breaking out between the labour corps workers and their guards in hab-zone four. Other labourers followed their lead, and were cutting themselves free of their chains and looting the armouries for weapons. The guards fled rather than face the enraged mobs.

Those still loyal to the Master-Prefect of Vraks tried to issue orders to raise the militia to combat the rebels, but found those orders quickly countermanded by the Cardinal's officers. For the next few days disorder reigned, it seemed like civil war had broken out on Vraks. There were bloody battles and riots

everywhere, often between sides who did not know why they were fighting. The Prioress of the Order of the Argent Shroud requested an audience with the Cardinal. Surely she should mobilise her battle-sisters and restore order, or at least aid the beleaguered Adeptus Arbites officers in Vraks star port. Instead she was immediately arrested by the Disciples of Xaphan and thrown in Vraks' dungeons. Following her arrest, the Disciples marched into the priory and arrested the remaining Sororitas sisters. Some fought back, but out-numbered and taken completely by surprise by the sudden treachery, the sisters were soon overrun. Those Sororitas that didn't die in the fighting were clasped in irons and hauled away to the dungeons. Meanwhile, the dungeons were also being emptied, and their former occupants presented before the Cardinal, the man who had saved them from their fate.

Under Deacon Mamon's orders the Disciples of Xaphan also moved against Vraks' Master-Prefect and the Administratum buildings were stormed. The Master-Prefect tried to run but was killed as he tried to reach the Citadel's shuttle landing pad. The entire Citadel was soon in the Cardinal's hands. The garrison followed their commanders' orders and confined themselves to barracks. Any who did not surrender and bow down before the Cardinal were executed by the Disciples of Xaphan. The censorium tower was also stormed, and the astropaths within slaughtered to a man. While across Vraks battles raged, the Citadel, the seat of power, had fallen from within. When the fighting outside subsided, Cardinal Xaphan was left as the sole ruler of Vraks.

*Opposite: A transcript of the final message from Vraks.*

# CHAPTER TWO THE COMING WAR

*"There will be no magnificent victory, no glory or honours to be won on Vraks. It will be cruel and pitiless. We shall bleed the enemy to death before he can bleed us."*

Lord Zuehlke. Commander, 88th Siege Army.

## The Departmento Munitorum Response

The Departmento Munitorum did not respond quickly to the fall of Vraks. It took a long time for news of the Vraks uprising to be confirmed and then for it to reach the ears of the Officio of the Master of the Departmento Munitorum for Segmentum Obscurus. Even then the Officio was unable to act without first contacting the Administratum on Terra. Months of inactivity passed as the bureaucracy at the heart of the Imperium slowly processed the new information. As the loss of Vraks steadily gained a higher priority, the wheels of the Administratum slowly turned.

The loss of Vraks could not be allowed to stand unopposed. Whilst a small world of just eight million souls was of little consequence when compared to the great crusades and the Tyrannic Wars now raging on the Eastern Fringes, it was Vraks' strategic position in the Departmento's logistical chain that made its loss so important. Who knew what future damage would be caused if Imperial Guard regiments in the Scarus sector, and further afield, found themselves running short on the munitions and equipment they need to fight their own battles? Readings from the Imperial Tarot on the subject of Vraks were all doom laden. The fall of Vraks was a significant loss to the Imperium's defences around the Eye of Terror. Surely, the Dark Powers would seize this opportunity to strike against other worlds in the Scarus sector. And if they should succeed, and more worlds fell, then wouldn't more heretic forces gather, like moths to a flame, to join the plundering? Ten years from now perhaps the loss of Vraks might be the spark that ignited a new Black Crusade. The High Master of the Departmento Munitorum could not take this chance. Vraks must be retaken, at any cost. But how?

The order to retake Vraks was issued to the Imperial Guard High Command of Segmentum Obscurus, situated on Cadia. The Lord Castellanus and Lord Commander Obscurus both sat upon the council as plans to retake Vraks were discussed. The order from Terra

was not an easy request to comply with. Any battle for Vraks would be a huge undertaking. Vraks was a world designed to withstand attack. Its defences had been constantly improved upon since ancient times. Vraks was a bastion world, impervious to direct assault - it had never fallen.

Many options were considered. Some commanders even argued that the entire scheme was folly, the sheer wastage of men and materials would mean other systems would fall; Vraks was gone, and the Departmento should turn its attention to avoiding such a disaster in the future, not planning a hopeless campaign to recover a situation brought about by their own lack of foresight and

judgement. The stockpiles on Vraks were lost. Why not write them off and concentrate on increasing production across the Segmentum to replace them?

The sceptical voices on the war council held little sway over the High Commander and his staff. The order to retake Vraks had come directly from Terra, under the seal of the Prefect of the Master of the Administratum's office - a high ranking servant of a High Lord of Terra could not be ignored. Failure to act was likely to be met with swift retribution from the Inquisition. Would anybody on the council prefer to answer for their failure in an Ordo Hereticus excruciation chamber?



It might have little hope of success, but there would be war for Vraks, that much was already certain. It was the council's job to decide how to conduct that war. The first option considered was the obvious one, a swift direct assault. This would involve an attack from orbit by a powerful Imperial Navy fleet, spearheaded by a force of the Adeptus Astartes. A messenger could be quickly dispatched to request Space Marines assistance in this matter. The High Command began their calculations to estimate what resources would need committing for a direct assault. The archives were scoured for information about Vraks' planetary defences – the dossier compiled was very large and made for daunting reading.

Since its first construction it had always been known that the Citadel and star port on Vraks would be vulnerable to an orbital assault. The defences had been designed to repulse just such an attack. Batteries of planetary defence lasers ringed them, maybe as many as a hundred operational guns. There was enough firepower on the surface of Vraks to fight an entire fleet in low orbit. The Imperial Navy's battleships and cruisers were hugely powerful starships, but no ship can fight a planet. With batteries buried deep to withstand orbital bombardment, the ships would be at a massive disadvantage in a straight fight. To land troops the ships would need to approach in low orbit, and they would be vulnerable as they manoeuvred into position to launch their landing ships. The landing ships themselves would

be targeted, and a single hit from a defence laser would tear a landing craft apart. Below the defence lasers was a network of high and low altitude anti-aircraft defences that could engage any craft that got through. The conclusion drawn from the Logis' calculations was that the risk of a direct attack was too great. The probability was high that a planetary assault would be repulsed with great loss. Troops that did reach the surface would not do so in sufficient numbers to capture the citadel. Even the mighty Space Marines would not attempt such an attack. No Chapter Master was foolhardy enough to risk the destruction of his valuable battle barges and worse still, his battle brothers, for the slim chance of victory. If they pursued this plan they would do it without the aid of the Space Marines and would be walking into a disaster. The fastest and most obvious solution was discarded. However Vraks would be retaken, it would not happen quickly.

Alternatively, a long-term strategy could be taken. Some suggested that they use the Imperial Navy to blockade the system, isolate it from reinforcements, then, over the course of, say, the next hundred years, launch repeated raids against the planet. Land small, well-equipped forces and strike hard at the defenders, in particular target the planetary defence batteries. Wear the defenders down, battery by battery. Perhaps after a hundred years of isolation and raiding, the defences would have been so thinned out a direct assault would be possible. Again the

logis calculations were not encouraging. Such a plan might work, if executed over a period of five hundred years. The Departmento Munitorum would reject such a plan as too timid and requiring too long. They would not wait half a millennium to regain their world.

The third option considered in detail was to plan and execute a siege on a massive scale. Land an army big enough to sustain the siege over the years required to pulverise the defences. Remorselessly and mercilessly grind the defenders down. If they could turn the recapture of Vraks into a war of attrition then, with the vastly superior resources available to them, they must eventually win. If the Departmento Munitorum was willing to match the defenders casualties at a rate of two to one, then how long, and how many men would it take to recapture the planet?

The human-computer logis began their calculations. Taking everything into consideration, replacement rates, supply requirements, the vagaries of warp travel times, the known stockpiles of arms on Vraks, the manpower available to the defenders, they estimated it would take twelve standard Terran years, including preparation time, until Vraks was back under the Emperor's rule.

The results of the Commanders' feasibility study were forwarded to the Master of the Departmento Munitorum's office on Terra. Here was a workable solution. Could the Departmento supply the necessary manpower and vast supporting logistical needs? The Departmento Munitorum eventually responded. The men and supplies would be found, and a new army would be founded for the recapture of Vraks. It was designated as the 88th Imperial Guard Siege Army.

**The 88th Imperial Guard Siege Army**  
All the men for the new siege army would be supplied from the planet of Krieg. Krieg was a world already in the highest tithe band for supplying manpower to the Imperial Guard. Only a few worlds in the entire Imperium produced more men for the Emperor's service. Known as the Death Korps, the men of Krieg were grim warriors who had developed their particular doctrines of warfare during their planet's bloody five hundred year civil war.

During the Krieg civil war, the loyalists had attempted to destroy the rebels using atomic purging. The planet had been wrecked as the mushroom clouds of ancient and forbidden weaponry erupted over Krieg. To survive the hellish

**88th IMPERIAL GUARD (KRIEG) SIEGE ARMY – ORDER OF BATTLE**

**1st line korps**

- 3rd Krieg Siege regiment
- 5th Krieg Siege regiment
- 15th Krieg Siege regiment
- 19th Krieg Siege regiment

**12th line korps**

- 143rd Krieg Siege regiment
- 149th Krieg Siege regiment
- 150th Krieg Siege regiment
- 158th Krieg Siege regiment

**30th line korps**

- 261st Krieg Siege regiment
- 262nd Krieg Siege regiment
- 263rd Krieg Siege regiment
- 269th Krieg Siege regiment

**34th line korps**

- 291st Krieg Siege regiment
- 308th Krieg Siege regiment
- 309th Krieg Siege regiment
- 310th Krieg Siege regiment

**8th assault korps**

- 7th Krieg Tank regiment
- 11th Krieg Tank regiment
- 14th Krieg Tank regiment
- 179th Krieg Siege regiment
- 231st Siege Artillery regiment

**11th assault korps**

- 61st Krieg Tank regiment
- 66th Krieg Tank regiment
- 101st Krieg Siege regiment
- 497th Siege Artillery regiment

**19th bombardment korps**

- 3rd Siege Artillery regiment
- 4th Siege Artillery regiment
- 8th Siege Artillery regiment

**21st bombardment korps**

- 19th Siege Artillery regiment
- 22nd Siege Artillery regiment
- 23rd Siege Artillery regiment

**Independent artillery companies**

- 4th Artillery company
- 6th Artillery company
- 8th Artillery company
- 27th Artillery company
- 31st Artillery company
- 33rd Artillery company
- 224th Artillery company
- 226th Artillery company
- 227th Artillery company
- 230th Artillery company
- 61st Heavy Mortar company
- 67th Heavy Mortar company
- 70th Heavy Mortar company
- 71st Heavy Mortar company



*Left: The task of recapturing Vraks would fall to the Imperial Guard Siege regiments of Krieg. Here, field artillery is towed into position by a Centaur carrier.*

irradiated battlefields the population, and the war, had gone underground. Labyrinthine trench works had stretched out across the planet. For long periods the civil war had been a stalemate, but it meant that for fifteen generations the fighting men of Krieg were raised and trained into a tradition of attritional trench warfare. When it came to these bloody and slow battles, the Death Korps of Krieg excelled. Unlike other Imperial Guard regiments, the moral character of the men of Krieg, forged by the civil war, was one of selfless sacrifice. They could withstand the horrific psychological damage caused by prolonged wars of attrition. In the past other regiments had cracked under the strain of such campaigns and mutinied. The Death Korps would never break, they would fight on, regardless of their losses. They knew no other way.

Overall command of 88th Siege army was given to Lord Commander Zuehlke, a son of a noble family whose influence stretched across the higher echelons of the Imperial Navy and Imperial Guard. His great-grandfather had once served as an attaché to the Lord Commander Solar on Terra. Lord Zuehlke's qualifications for leading the campaign, apart from his social rank, were few – beyond his martial upbringing and detailed study of the *Tactica Imperialis*, but political pressure and a good family name yielded its rewards. Lord Zuehlke was assigned a large staff to begin the long process of mustering his army and planning the war for Vraks.

The lengthy preparations for the siege of Vraks were, in essence, brutally simple. How many men must die to retake

the planet? Planning to overwhelm the defence lines, destroy the planetary defence batteries, and eventually storm and capture the citadel and star port was reduced to a mathematical formula. Everything in the 88th Siege army was an expendable resource. How many men to dig a trench and how many shovels? How many men would be needed to capture a hundred metres of ground, or storm a strongpoint? How many guns to pulverise an enemy trench line? How many tows, crews, shells, replacement barrels, ration packs, water supplies? The lists were endless. List upon list was compiled, all of it pre-calculated. Before a single guardsman had been assigned to a regiment, or a single weapon manufactured, the 88th Siege army existed on thousands of data-slabs as lists.

It was the most impersonal sort of warfare. Within the Death Korps regiments the men were not named, just numbered, so they could quickly be tallied-up and counted off the lists. The regiments would be ordered into battle already knowing how many would be expected to die. By meticulous logis calculations the 88th Siege army could precisely predict the outcome of each battle. What was to be gained, and for how many losses? The lives of the Krieg guardsmen were no more important than the daily fuel consumption rates or the expenditure of artillery shells. The formulae would decide where battles would be fought, and by how many. It also assured them of ultimate victory in twelve standard Terran years.

#### **The Defenders of Vraks**

On Vraks the sudden uprising and the Cardinal's victory had escalated

into an avalanche of mob violence. For several months the rebels fought amongst themselves to establish a new power structure around the Cardinal. New leaders emerged from the garrison and the labour corps. Those who proved their loyalty to the Cardinal's regime were rewarded with positions of power. The very best were inducted into the Disciples of Xaphan or given roles as enforcers – the Cardinal's cadre of brutal strongmen who oversaw the rank and file, enforcing obedience and discipline.

After the rioting and bloodshed was over, the Cardinal's commanders set about their first task – to defend Vraks from any reprisal attacks. They had to prepare their men and train an army. They had vast quantities of Imperial Guard supplies to plunder. Their army would be well-equipped and occupying very strong defences, but still they must be prepared for whatever the Imperium would throw at them. The Cardinal issued instructions that Vraks should be turned into a slaughterhouse. He made it clear that no defender could now expect any mercy from the attackers, they must fight, or face inevitable execution by the enemy. Only by defeating the enemy could any man expect to survive. For those that fought well there would be great rewards. For those that failed in their duty to their leader, there would be summary execution at the hands of his enforcers.

After the uprising the rebels newly won freedom was short lived. The labourers were soon put back to work, improving the defence lines, moving minefields or laying new ones and rolling out miles of razorwire. Artillery crews practiced

ranging shots and pre-sighted their guns. The renegade militiamen, whether willing or co-opted, trained with their newly looted weapons. The Cardinal's army was well prepared. When it came, the battle would be deliberately hard fought and bloody. Such slaughter would please Xaphan and ultimately grant them victory.

### **The Opposing Armies**

The army that the Imperium was about to engage on Vraks was a formidable force, mainly due to its sheer size. Although no exact figures were available, it was estimated that Vraks population was eight million souls, and all of these now had to be considered as traitors and probable manpower for the heretic Cardinal's army. It would be made up of various quality of troops, ranging from the well trained, well equipped and fanatically loyal, to an undisciplined mob.

Vraks' best troops would be the Disciples of Xaphan. This cadre of elite troops were the Cardinal's own men, hand picked by his representatives for their loyalty, and many had been chosen because of their previous military experience. All had sworn oaths of service to the Cardinal himself, and in return they had the pick of Vraks' considerable plunder. The Imperium had no idea how many Disciples the Cardinal now surrounded himself with, but they would form a solid core to his Vraksian army.

After the Disciples of Xaphan there was the garrison auxilia. Due to its location and its strategic importance Vraks had been guarded by a huge force of garrison auxilia. These were broadly equivalent to a planetary defence force, the Imperium's second line of military forces behind its Imperial Guard regiments. The auxilia did not have the training or equipment of a regular Imperial Guard regiment, but access to Vraks' stores would have rectified any equipment shortages and given the garrison access to vast amounts of heavy equipment, Leman Russes, Chimeras and Basilisks. How well they could operate this equipment was unknown, but the garrison's fighting strength had been built around a backbone of veteran Imperial Guardsmen and officers drawn from disbanded regiments that could not be rebuilt. Whilst being well equipped it was thought unlikely that the garrison's forces would be able to mount well planned and co-ordinated operations, but that they would be easily capable of manning a bunker or defence line in a more static defensive role.

The traitor's next form of manpower was the labour corps. The Departmento Munitorum labour corps on Vraks was large and included many Ogryns. The labour corps were indentured workers doing routine work such as constructing and repairing roads, pouring ferrocrete bunkers to strengthen the defence lines, digging and blasting out new

underground storehouses, and transporting goods to and from the star port. Most were wretched souls living a gruelling life of remorseless hard work. As a result many had joined the Cardinal's rebellion willingly and saw fighting for their leader as a chance to escape a life of pitiless toil. A general dislike for the Departmento's current Master-Prefect on Vraks, due to his poor treatment of the labourers, also helped spur them into rebellion. Many of the labourers had already been given some basic military training. As well as working, the labour corps also supplied manpower for Vraks' militia. In the event of an attack the planet's garrison was not large enough to man the defence lines, instead this would be the job of the militia. Labourers who joined the militia enjoyed a few extra privileges in rations and accommodation as well as receiving training days. Although only rudimentary training was given, Vraks' militia was a massive force. One in four labourers either volunteered or were conscripted into the militia. Lacking any sort of heavy weapons, artillery or vehicles they were a third line force, but, again, their lack of equipment could be quickly rectified and once armed from the stores, and with additional training, they would be capable troops whilst holding static defensive positions.

The fourth source of manpower for the Cardinal's army was the itinerant pilgrims and the Departmento Munitorum's own workforce of administrators and bureaucrats. These were effectively men with no military experience, but like the labourers, once armed they could hold a position. Whilst many of the pilgrims saw the Cardinal as their messiah, most had no idea who or why they were fighting. Many volunteered for the *frateris militia* in the belief they were defending the shrine of St Leonis against heretic forces, as was their holy duty. They had been told that the enemy were in fact the heretical renegades and that they must join the militia or see a holy place defiled. Again weapons could be found from the stores - although it seemed these troops would be given the lowest priority when the stores were being issued.

To back up these renegade forces, were Xaphan's own men, his agents and preachers who moved through the ranks teaching the Cardinal's gospel and reinforcing the troops' loyalty. Individuals from the garrison force, often former sergeants, had been promoted to enforcers. These were men whose job was to enforce discipline and loyalty, much like the Imperial



*Above: Men of the Death Korps struggle to move equipment through Vraks' quagmire.*

Guard's commissars. In battle the enforcers would stay behind the front lines and shoot any man that deserted his post. More worrying still were those individuals released from Vraks' dungeons. Added to the renegades' ranks were the dangerously insane or psychopathic, as well as individuals who had shown signs of developing psychic powers. Dangerously unprotected psykers were easy prey to warp entities, and there were several hundred such individuals in Vraks' deepest dungeons awaiting transportation to Terra on the next Inquisitorial Black Ship to arrive. The Cardinal saw these rogue psykers as his own children, and claimed they based messages to him from the gods!

Whilst the defenders of Vraks might be of wildly varying quality, especially in morale, they would be well-equipped, and their main advantage would be that they already occupied a formidable defensive system.

The forces required to assault these formidable defences would be the Imperial Guard regiments raised from Krieg, the infamous Death Korps. These would be amongst the best Imperial Guard regiments available to the Imperium. The men of Krieg were loyal, dutiful and superbly disciplined. They would fight with an almost inhuman disregard for the cost, seeing death in battle as their ultimate goal, sacrificing themselves to the Emperor.

The 88th Siege army's morale could not be doubted, that was the very reason they had been chosen in the first place. They would be well-equipped from Krieg's own armouries. How they were equipped would vary depending on a regiment's designation. For this campaign most of the regiments would be siege regiments, equipped for a long static war, with a special reliance on artillery. The artillery lay at the centre of the plan for besieging Vraks, it would be a gunner's war from the start. Guns were the key to success, and large concentrations of heavy artillery would be expected to blast the enemy from their defences, allowing infantry attacks to sweep forwards in their wake. Each regiment would comprise of its own artillery companies, with weaponry ranging from small mortars used on the frontline, to the medium artillery of heavy mortars and quad-launchers. There would also be heavy artillery in the form of Medusa siege guns and Earthshaker cannons – the work-horse of the 88th Siege army, to the heaviest guns of all, the mighty Bombards. These huge siege guns would be needed

to destroy the enemies' deepest defences. To augment each regiment's own artillery, the 88th Siege army's commanders could also turn to a variety of independent artillery companies and regiments, including heavy siege artillery regiments, which would be positioned to strengthen the artillery available for attacks.

Other regiments would be equipped as more mobile armoured regiments, but for a siege campaign these would be used as breakthrough and exploitation forces, and would not expect to be spending long periods manning the lines. The tanks would be used to support infantry attacks, there would be no mass tank battles and the plan intended to stifle the enemies' chance for mobile warfare. Still, Leman Russes, Baneblades and Gorgons would have their part to play in assaulting the enemy.

#### **The Battlefield**

For the men of Krieg, Vraks would be an alien environment. All of them had been raised in Krieg's underground hive cities, where they had become used to overcrowded conditions and breathing recycled oxygen. They had trained for battle on their planet's surface, amongst the bitter cold of a nuclear winter and over a landscape of ruined buildings and an intertwining mass of trenches and rusting razorwire, left by the civil war. They had braved the rad-zones and fought mock-battles against other training regiments. They had marched and dug trench lines. It had been grueling and some recruits had not survived the punishing regime, but no matter how hard, it had just been training. They were now entering the crucible of battle, most regiments for

the first time – even though they bore regimental numbers with a long tradition and history, these were reconstituted regiments brought up to strength with many new recruits.

Vraks itself was a barren and drab planet, covered in a sulphurous layer of old volcanic dust, it was bare and rocky. The climate was warmer than Krieg, but violent electrical storms were a daily occurrence, the sudden downpours drenching everything before ending as suddenly as they had started. These storms turned the ground into a sticky grey quagmire as the water drained away through Vraks' porous surface.

The battlefield itself would encompass almost the whole of the Van Meersland Wastes, five thousand square kilometres of barren emptiness, with its long gentle folds and occasional rocky outcropping of harder volcanic rocks not yet worn away by the rainwaters. It was almost featureless, but it was terrain the enemy already knew well. The Departmento Munitorum had supplied maps for the Krieg officers, but many contained no features of note. The enemy knew where the high ground was, where to position his guns with the best fields of fire. All of this intuitive understanding of the battlefield would have to be learned by the attackers as the campaign progressed.



*Above: Baneblade super-heavy tanks would support the tank regiments of the assault korps, for breakthrough operations against the strongest enemy defences.*

## DEATH KORPS OF KRIEG INFANTRYMAN



### 1. ARMOUR

**Helmet.** The standard issue mark IX helmet is made of plasteel, has an adjustable cradle for fit around the head, flares to allow a good fit for the gasmask and is ventilated via the top spine. This ventilation has an internal filter to keep out chemical or biological agents. There are many variants of the standard mark IX helmet issued to specialists and officers. For example, officer helmets have extra decoration as befits their seniority.

The shoulder pads are of plasteel construction and buckle to the greatcoat. Watchmasters' and officers' shoulder pads are embossed with rank insignia.

### 2. UNIFORM

One of the most distinctive features of the regiments raised on Krieg is the heavy greatcoat. It is manufactured on Krieg from a hardwearing thick cloth and produced in a variety of colours, from dark green to brown, greys and black. The great coat provides limited protection, but is also heavily chemically impregnated against chemical and biological attack – an unfortunate side effect of this being the pungent smell emitted. The greatcoat is completely waterproof and very warm, useful when deployed to colder climates. The great coat is double breasted and includes brass buttons, a pair of which allow the coat's front to be turned back (as shown here), to allow for greater mobility in combat.

The greatcoat's collar bears the regimental tag stitched to the coat. At the beginning of a campaign, high command will designate a colour and shape to each regiment. In this case a red triangle. Other regiments will get red squares or yellow circles, etc. These aid battlefield identification for Quartermasters. The guardsman's trousers are constructed of the same hardwearing material as the coat. Leg-bindings are used to hold the trousers close to legs and limit the worst effects of muddy conditions. Boots are standard issue low marching boots with hob-nailed soles for grip. As part of their kit, guardsmen carry an anti-vesicant dubbing which is rubbed into the boots to seal them against chemical attacks.

When fully equipped, a Krieg guardsman is completely sealed against a contaminated environment by the layers of his uniform and his respirator unit.

### 3. WEAPONS

The guardsman's main weapon is his Lucius pattern, no. 98 lasgun. This weapon is standard issue to Krieg regiments, and stockpiled in vast numbers in Krieg's armouries. It takes a standard power pack unit, operating in the 21 megathule range. This is a higher charge than many of the more common lasgun patterns, and causes the powerpack to drain more rapidly than in other lasguns. The powerpack is good for 25 shots. This lasgun is a single shot weapon, and the weapon's internal fast discharge generator is placed under extra stress by the larger charge, reducing its recharge rate and slowing the weapon's rate of fire whilst increasing maintenance time. This is compensated for by the charge's increased impact upon hitting the target.

The weapon's barrel includes additional heatsink rings to dissipate the heat of the barrel, which infamously gets very hot during sustained firing. The lasgun also includes a bayonet lug and a basic back sight. The weapon's stock is a synthetic wood, although variants are manufactured with metal stocks.

This guardsman is also armed with a frag grenade. It is a standard issue no.38 fragmentation grenade. All Krieg guardsmen are equipped with a single grenade, but additional grenades will be issued to squads before an attack.

All Krieg soldiers carry a 45cm long sword-bayonet. This heavy bladed, razor-sharp knife is the guardman's only close combat weapon, and bayonet drill is practised from a very young age. All Krieg guardsmen are highly proficient with the bayonet, so much so that some commanders have remarked that the bayonet seems to be the regiment's main weapon, and is more effective at driving the enemy from their positions than all their artillery and heavy weapons platoons. The bayonet charge remains a preferred tactic of Krieg commanders.

### 4. EQUIPMENT

All Krieg guardsmen are issued with their distinctive respirator units. The respirator comprises of three elements; the gasmask, the hose and the respirator regulator unit, which is worn on the chest.

The regulator unit is easily a Krieg guardsman's most complex piece of equipment. It contains particle filters, a battery powered fan which draws air into the regulator, through the filters and then forces it up the breathing pipe. The advantage of this being that the breathing apparatus works via 'positive pressure', blowing clean air into the gasmask. Should the system be compromised, then the constant flow will force air out of any hole, and not draw it in, thus helping prevent toxic particles entering the system.

As well as particle filters, the regulator also samples the air for toxic agents, and will automatically introduce antidote chemicals into the air supply to be inhaled by the soldier. The regulator's satchel also contains a water flask which feeds into the gasmask. The water supply is supplemented by soluble stimulants and nutrient tablets, which allow the guardsmen to operate beyond human physical norms.

The respirator unit has no oxygen supply, so oxygen must be present for the soldier to breathe. The exterior display panel allows officers to see how well the regulator is functioning and other guardsmen to see how toxic the atmosphere is.

*continued overleaf*

This is guardsman 566-648-87991-72- Draeta, of the 143rd Siege Regiment, 6th platoon, 24th company during the Siege of Vraks. He is wearing the standard issue uniform of a Death Korps of Krieg infantryman.



*continued from overleaf.*

The entire regulator unit is carried inside a leather satchel, which buckles onto the webbing's shoulder straps.

The heavy exterior hose actually surrounds and protects two narrower pipes: an air pipe and a water pipe. The hose screws into the end of the gasmask via the breather valve. This brass fixture contains an additional filter and a non-return valve, so the air flow is one way. The breather valve allows expelled air to escape via small holes on the inside of the brass ring.

The gasmask consists of a bag, a screw attachment for the breather valve and eye pieces. The eye pieces have a double layer of toughened glass and are treated with an anti-fogging compound.

Webbing: Leather webbing includes carrying straps for the backpack, respirator filter unit and regulator, four

ammunition pouches for lasgun powerpacks, additional pouches for carrying other kit, such as weapon and respirator maintenance kits, replacement filters and antidote vials, etc.

Backpack: The leather backpack buckles to the webbing shoulder straps. It has additional straps to attach a bedroll, which also doubles as a waterproof shelter-half, and a dry-tin canister for storing perishable materials sealing them against the environment.

Small entrenching tool. All Krieg guardsmen are required to dig. Trench warfare being their preferred method, they must constantly dig new trenches, or repair and improve their current position in the line. Each guardsman carries an entrenching tool - a small spade. The tool's carrying case is worn on the belt and also has loops for carrying the bayonet when not attached to the lasgun. Larger tools such as mattocks and shovels will be issued when needed for heavier work.

## CHAPTER THREE

# THE KILLING FIELDS OF VRAKS

*"Our creed is this. We are ready, at any moment, to sacrifice all for victory."*

Colonel Cseke, 15th Krieg Siege Regiment

### Vraks Landings

At 790812.M41 200,000 guardsmen of the Krieg 143rd Siege regiment marched, grey great-coated rank after great-coated rank, up the boarding ramps and into the holds of their transport vessels. They were the first men of 88th Siege army to begin their journey to Vraks. They were just the beginning of a vast armada of vessels in orbit above Krieg now preparing to load and rendezvous for the journey to Vraks.

Lord Commander Zuehlke established his headquarters on Thracian Primaris, a principal planet of the Scarus sector. His unstoppable war machine was now in motion, his personal presence on Vraks itself was not required. He would oversee the campaign from a comfortable distance. Victory was already assured, all he needed to do was see that the replacement men and supplies kept rolling in on time.

The first convoy of transport ships carrying men, equipment and supplies from Krieg began to arrive in the Vraks system at 199812.M41. The vanguard of 88th Siege army was carried in twenty one transport vessels of various sizes, protected by a fleet of Imperial Navy escort ships under the command of Admiral Rasiak from his flagship, the cruiser *Lord Bellerophon*. They plotted their course to approach Vraks from the safety of its far side, well out of reach of the planet's defence laser

silos. The defenders had no fleet with which to meet the inbound armada, and the landing operations could begin in relative security.

The landing zones had been chosen to provide the 88th Siege army with a secure bridgehead on the surface, a place to build up its supplies and regiments before any battle would be fought. The landing sites needed protecting against enemy attacks, so the first regiment to land, the 143rd, set about digging-in. The first trenches were sited and begun. Atlas Excavators, an engineering variant of the Atlas recovery tank carrying trench digging equipment, set about ploughing up the trench lines, then minefields and razorwire were added to the defences. The 143rd regiment's Death Rider companies were sent to patrol the surrounding terrain, to seek out any sign of an approaching enemy attack, but all reported a barren and empty wilderness. The enemy made no move to prevent the landings or the build-up of troops, instead he occupied his own defences and dug himself in deeper.

For months the landing zone was a hive of activity, as the big landing ships roared overhead ferrying more troops and more guns down from the transports in orbit above. Shuttles went to and fro constantly and the supplies they delivered were stockpiled in vast reserves of food, ammunition, water and every other item the army would require

for its twelve year war. It was a massive undertaking, and it would continue until all the 88th Siege army's regiments had arrived.

It took almost a year for the army to be fully in place. In the meantime the Departmento Munitorum had also landed a large labour corps. It consisted of half a million men from the penal colonies of Arphista with a special mission to assist the war effort. When the fighting men and equipment were in place on Vraks, they would still have over a thousand miles of barren wilderness to cross before they reached their first objective. Men, mounts and vehicles could not be expected to march so far and reach the enemy in any condition to fight, so instead an alternative transport system had been planned.

The labour corps set to work digging and laying railway lines. Track was laid night and day, and the lines rapidly extended northwards. When the time came, the railway would transport the regiments to forward depots, before they made their approach march to the enemy defence lines. Onboard one of the largest transport ships came a delegation of Adeptus Mechanicus Engineers, and with them came their locomotives - great bellowing machines of steel and wheels, capable of pulling hundreds of heavy carriages. The Engineers did their work, and soon the locomotives were in place, ready to pull the 88th Siege army into striking range

of the enemy. As the build-up of fighting material progressed so did the tracks. At 965812.M41 the first locomotive set off, carrying the men and guns of the 3rd Siege regiment. It powered across the Saritama plains night and day. On arrival the regiment established the forward depot, they were now less than a hundred miles from the enemy's lines. From here the men would march to the front. The locomotives rolled non-stop carrying men forwards, whilst the labour corps worked to maintain the track and extend the main line with branch lines to secondary depots for storing ammunition, fuel and other vital supplies. The massive logistical support for sustaining the Krieg regiment's method of waging war was now in place.

**The Campaign Plan**

The 88th Siege army's plan for the reduction of Vraks' defences, and the eventual recapture of the Citadel, involved repeated offensives on two fronts. Rather than massing for one attack at a single point, and allowing the enemy to amass his forces to block it, the line korps would attempt to encircle Vraks and apply pressure all along the line. The approach to the Citadel was dictated by the terrain. To the south and east was an area criss-crossed by Vraks' distinctive gorges and canyons,

unsuitable for any attack and creating an impassable barrier to an army advancing on foot. When their forefathers had first sited the Citadel they had planned its location well. The attack would have to come from the west and north, and here the vast majority of the defence lines were situated.

1st and 30th line korps would form the northern part of the attack, whilst 12th and 34th line korps formed the southern part, occupying an area from the Saritama Abyss to sector 45-45. These two korps orders were to breakthrough the western outer defence line.

The 1st line korps' orders instructed them to attack the northern defence line, having circumnavigated the western defence lines. It may even be possible for them to push further eastwards and avoid the northern defence line, which had never been completed, and attack directly south from sector 57-53 into the second defence line. Of course, all korps attacks needed good co-ordination, to avoid regiments becoming too far advanced and vulnerable to strong enemy counter-attacks. Each gain must be taken carefully and steadily. It was not in the Krieg regiments' doctrine to drive deep into enemy territory without the support of flanking regiments.

With the outer defence lines overrun, the encirclement could begin properly. As the regiments approached the second defence line, the army's overall frontage would shrink, and make all its regiments less vulnerable to enemy counter-offensives. For this reason it was important that the first defence lines be overwhelmed quickly, at any cost. At the second defence lines regimental commanders could be more cautious and take their time to probe for weaknesses before committing to major attacks. Once the second line was cracked, the ring around Vraks' citadel could close in again to the inner defence line, entirely encircling the Citadel and for the first time bringing it under long range artillery fire. Then the defenders would know their cause was lost. Once in position the 88th Siege army could then afford to sit and wait; with the enemy penned in, there would be no respite or hiding from the big guns of Krieg, which would eventually pound them to destruction.

**The Beginning**

Imperial records show that there is an official time recorded for the beginning of the Siege of Vraks.

As the grey glimmer of dawn showed on the horizon, casting its thin light

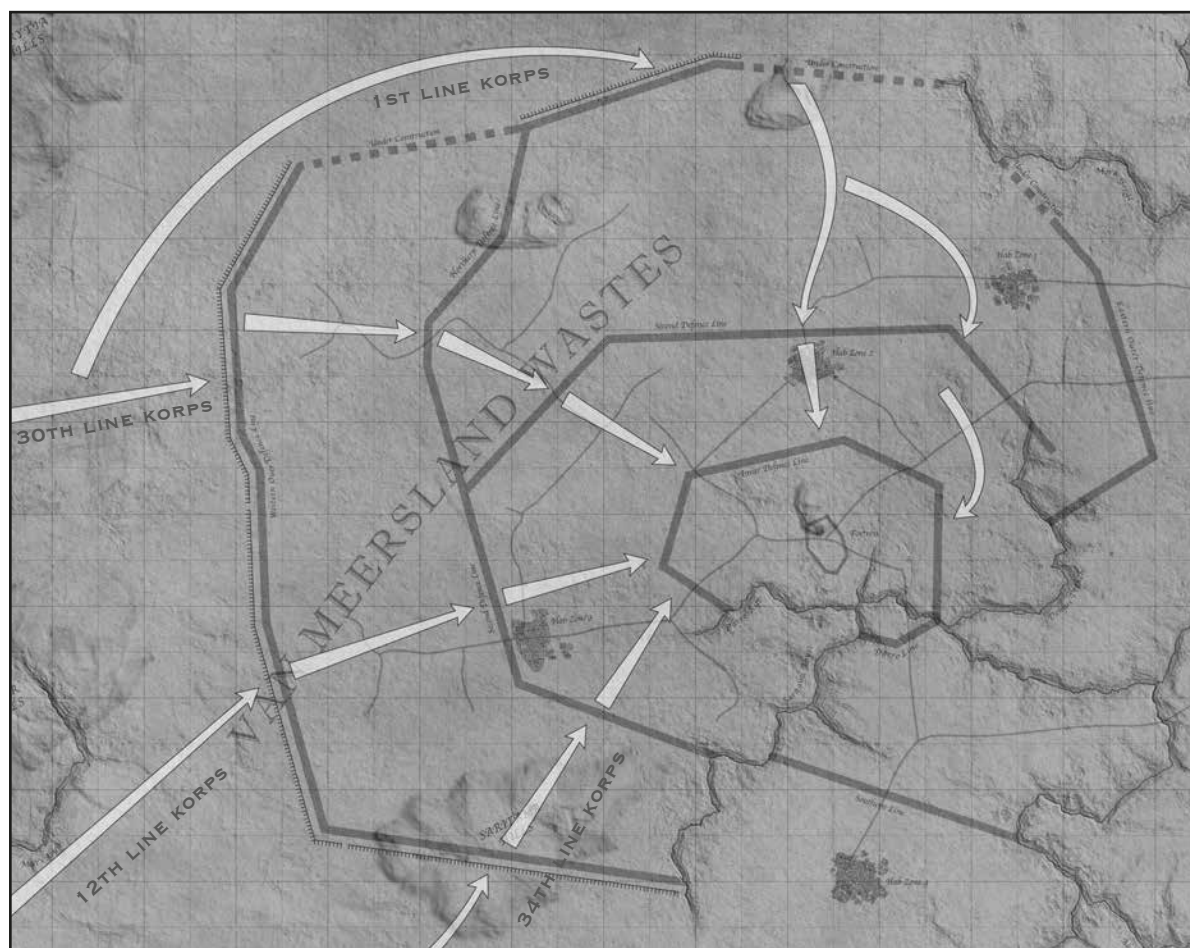

*The overall campaign plan, showing the encirclement of Vraks' Citadel by the four line korps.*

across the Van Meersland Wastes, sentries in the outposts of Vraks' outer defence lines stared, bleary-eyed, out across the cold, dusty landscape. Miles away to the west, many eyes stared back – watching through range-finder surveyors and scanners and awaiting the order to fire. Gun crews stood to attention beside their guns. Heavy Earthshaker barrels were raised to the sky in an ominous salute to the new dawn. Behind, the gun's shells were laid out ready for a sustained bombardment. Battery commanders checked the shell fuses, and awaited the code-words through their vox-casters. Suddenly the comms-box crackled into life, static hissed and a stream of high-pitched bleeps came through. The operator quickly flicked switches and the vox-caster de-scrambled the flash message. Turning to the awaiting commander the operator confirmed, "signal is correct sir. Open fire." The commander turned and raised his arm. Gunners and crews braced themselves as the order was received over their helmet communicators. The commander's arm fell. "OPEN FIRE!"

An unnoticed Administratum archivist-scribe noted that it was 166813.M41, and the Siege of Vraks had begun.

Nearly fifteen kilometres away the shells landed with a splintering crash, throwing pulverised stone and grey dust into the sky in thick plumes as the flames of the high-explosives within roared. Shards of shrapnel whirled in all directions. The air was suddenly thick with grey dust and red-hot metal. The crescendo of explosions grew, its tempo rising as the Krieg gunners warmed to their work. Over the din of Earthshaker rounds came the terrible howl of heavier Bombard shells, falling steeply to add to the storm now erupting. The shells blew great craters in the soft earth. Rocks the size of paving slabs were tossed into the air, falling like rain, only to be picked up and flung again as the next shell impacted. All morning the bombardment went on, hammering the outer defence lines, explosion after explosion, until the gun barrels of the 88th Siege army began to glow red with the heat of firing.

Meanwhile, behind the outer defence line's forward positions, the defenders' gunners were racing to respond with counter-battery fire. Basilisk artillery pieces trundled forwards into pre-prepared firing pits, well protected from enemy fire. Their hydraulic pistons complained as their barrels climbed skywards. Breeches flew open, shells clanged into place before the breach

door slammed shut and the locking bolts were screwed into place. A final check of range to target, elevation, traverse... and the Basilisks fired, the recoil driving the forty tonne armoured vehicle violently backwards as the dampers strained to withstand the energies released by the shot. The artillery duel had begun.

Far away in the Krieg gun lines the scream of incoming shells could not be heard over the crash of their own guns firing. The Krieg gunners laboured with shells and charge bags as sporadic explosions suddenly fountained around them. The first enemy shells landed well short, then wide, then growing ominously closer. At the 413th battery an enemy shell scored a direct hit, smashing an Earthshaker cannon to pieces like a child's toy, detonating the ammunition stockpiled close-by and killing all eight members of the gun's crew in the ensuing inferno. It was a lucky hit at the extreme range of the enemy guns, but it signalled that the artillery duel would not be a one sided battle.

As the artillery duel was getting under way, the men of 158th regiment advanced at an even pace, each man five yards apart, long dark ranks of trench-coated, gas-masked figures, moving steadily forwards. Overhead shells tore through the sky, rumbling and screaming on their way to targets either far ahead or far behind. Whilst the artillery targeted each other the infantry advanced ever onwards, almost forgotten by the artillery duel that blazed above them.

Orders were that infantry action today was to be limited to a steady advance towards the enemy, then a halt with enough time to begin the work of digging the first trenches. The men were not to attack the enemy positions yet, the artillery would need far longer to soften-up the enemy than a single morning, but the heavy shelling was acting as a covering bombardment, preventing the enemy from engaging the advancing infantry at long range and harassing the enemy's own artillery positions.

By nightfall the first foxholes were dug, two men to a hole, scratched six feet deep in the earth. Tomorrow each hole would be extended, via a narrow trench to contact with the next foxhole. This way each squad would establish a single basic trench. This could then be connected into a platoon trench, and then they too would be linked into a company trench, which could then in turn be linked into other company trenches. Over the course of days, the

trench lines would start to spread.

These first hand-dug trenches, maybe six feet deep and two feet wide would then become the basis of a more permanent frontline position. From the relative safety of the trench, it could then be widened, sandbags would be filled and stacked. Under the cover of darkness, razorwire teams would stretch coils of wire in front of the trench to prevent enemy patrols or raiding parties gaining easy access. Heavy weapons positions would be sited, then dug. The beginnings of dugouts could be seen, burrowed into the trench walls. A platoon would rotate duties. Whilst two squads stood sentry another two would dig, whilst the final two squads rested. It was all meticulously planned and efficient. It was the way the Death Korps regiments had trained to do it back on Krieg. With entrenching tools, shovels and picks the guardsmen hewed out their new home. Platoons and companies competed with each to see who could complete their work fastest, just as the cadet platoons did during training on Krieg.

On Vraks the pumice-like rock broke down easily, and the trench lines grew quickly. It was filthy work, turning the men into dusty grey ghosts, and with each passing storm shower the trenches became a swamp of cloying grey slime, but within a week the forward positions were in place. From this base they could begin cutting communications trenches backwards to link up with rear units, or tunnelling forwards to make forward outposts, from which they could harass the enemy positions and gain an early warning against any enemy moves.

Despite the Death Korps' methodical digging, the enemy did not attack. Pinned under the daily bombardment the enemy clung to his solid bunkers and defence lines, offering little fight except sniper shots and harassing mortar fire. The two lines were drawn up parallel to each other, staring across the vacuum of no-mans land, which neither side ventured into.

Whilst the Death Korps were digging-in and reinforcing their trenches, Cardinal Xaphan's renegade army was occupying the prepared positions opposite. They might be called defence lines on the maps, but there was no single solid line. Each was more of a defensive zone, into which had been placed trenches, defence line (these were low reinforced ferrocrete and plasteel walls) usually connecting pillboxes. There were heavy bunkers with multiple firing slits for heavy weapons, weapon pits reinforced



*Top: The Siege of Vraks would be a gunners' war. A field artillery strongpoint unloads extra ammunition between fire missions. Above: A squadron of Death Riders range ahead of the marching columns, to scout enemy positions and screen troop movements from attack.*

by sandbags and, where necessary, ad-hoc barricades built of rubble filled fuel drums, corrugated steel and flak boards. Burrowed underground were personnel shelters to protect the defenders from enemy artillery. All these positions were protected by miles of tank traps and razorwire, as well as anti-tank ditches and minefields.

Since the uprising, the enemy had re-laid millions of mines, so that any Imperial intelligence on the location of minefields was now invalidated. In places the defensive positions were combined into strongpoints, resistance nests that were strong enough to withstand the heaviest shells. These nests usually provided the defenders with interlocking fields of fire for mutual support. In all each defence line might be as much as five miles deep, providing the defenders with excellent cover and a defence in depth. Breaking each defence line would be a major undertaking, and any advance would have to be bought at a high price in casualties. To make matters worse, the three main defence lines surrounding the Citadel became gradually denser and harder to crack the closer the enemy came.

#### **First assault on the Outer Defences**

Each line had to be broken in turn, and the bloody business could not be delayed. The first Krieg offensive would have to be soon if the planned timetable was to be kept to.

The 149th regiment was chosen to make the first assault in sector 46-39. From intelligence reports, gathered from information known before the uprising, it was felt that the defence line might be cracked here. Work here had not been completed and it provided a chance of the desired rapid breakthrough. On the 149th regiment's immediate left and right flanks the 143rd and 150th regiments would provide strong supporting attacks, to pin-down enemy units and draw enemy reserves into their sectors and away from the main effort. Behind the 149th regiment, units of the 11th assault corps were brought up and made ready. Should the first attack deliver the required hole, then the assault corps' tank units could drive through and thrust deep into the defence zone.

At 212813.M41 the first infantry attack was set to begin. Half a million men would attack in waves over the course of two days. The first wave was not expected to make much progress, but was to attack with strong infantry probes to find weak spots in the enemy lines. The second wave, led by grenadier units, would hit these weak spots hard,

gain a foothold in the defence lines and hold them until day two, when the third wave, would move through them and expand the hole. Once this was complete, the 61st Tank regiment would be released from reserve to smash through the hole. All this would follow days of heavy bombardment in 46-39 and its adjoining sectors.

Preparations for the first offensive were well in hand. Large numbers of guns from the bombardment corps and more men for the infantry companies were being brought forward into position – all the time under harassing enemy mortar and artillery fire. The artillery plan for the first attack was highly complex. In the front trenches were the infantry's own mortars, these would provide plunging fire into enemy trenches as the guardsmen went over the top. Behind them, in the second line of trenches would be heavy mortars and quad launchers, targeting identified enemy heavy weapons positions. Still further back would be Medusa siege guns, targeting enemy bunkers and pillboxes. Further behind even these would be the Earthshakers, providing a dense rolling barrage that would precede the infantry companies to pin the enemy infantry in his shelters. These guns would then switch to counter-battery fire against suspected or detected enemy artillery positions. Finally, there were the Bombards. These monstrous guns would be adding their considerable weight to the rolling barrage, then switch to hit enemy strong points deeper in the defence zone. Over four million artillery shells had been stockpiled to support the offensive, it would be the heaviest barrage of the war yet, concentrated across three sectors.

The guns of the 21st bombardment corps opened fire, assisting the siege regiment's own artillery companies. It began five days of shelling that would soften up the enemy for the coming attack. The remorseless guns pounded their targets, turning no-man's land and the forward enemy positions into a cratered moonscape. From the trenches it seemed nothing could survive such a long and heavy barrage. The guns hit everything that could be seen; tank traps, razorwire, bunkers, service roads that might provide rapid movement of reinforcements or supplies. It was a devastating display of firepower, and it kept up its drumbeat tempo day after day. With terrible monotony the shells kept falling. It seemed that when the attack went forwards, there would be nothing left to stand in the way.

At 212813.M41 the first attacking companies were in place, filling the front line trenches as the squads packed in shoulder to shoulder. In front of them was just a trench wall and a scaling ladder for the short climb into no-man's land. The previous night, protected by darkness, wire teams had been up and made gaps in their razorwire for the attackers to pass through. Company commanders awaited the order to advance. Platoon commanders awaited the word from their company CO, sergeants awaited the word from their platoon commander. Overhead the barrage intensified, crescendoing into a rolling thunder of noise as the explosions followed each other so quickly they became a single wall of noise. Then it was over. There was a sudden horrible silence as the guns lifted their barrage, right on time.

The order to advance was given over the vox-net and, as one, the first squads surged towards the scaling ladders. One by one the men appeared above the parapet and moved forwards, dodging through their own wire to form lines of dark, hunched figures advancing through the craters of no-man's land.

When the guns stopped enemy squads rushed to man their defences. Their positions had been churned into ruin by the bombardment, defensive walls lay demolished, trenches were buried in earth, and bunkers had been destroyed by direct hits, killing whole squads in a single explosion. But despite the ferocity of the bombardment many of the enemy had survived, hidden deep within their personnel shelters. Now, as enforcers and officers roared orders, they ran to their positions. The Death Korps was coming, and now they had to fight.

Ten yards, twenty yards, the infantry advanced unhindered. Then the guns began to rattle. Heavy bolter rounds flashed across no-man's lands, eating up the ground as the shells exploded amongst the ranks of advancing guardsmen. Onward came the Death Korps, resolute and steadfast, the front ranks in parade ground order. And so they died, scythed down by enemy fire, man after man, as they walked head long into a pitiless hurricane of fire.

Next, enemy artillery fire began to land. The guns had been pre-sighted, and the fire was accurate and lethal. Suddenly no-man's land was alive with explosions, plumes of flames and earth were fountaining amongst the attackers' lines. Clouds of smoke and dust thickened the air. Bodies were flung high into the air like rag dolls by the shell impacts. But still the advancing

lines did not falter, on they came, walking ever forwards into the firestorm. In the short distances across no-man's land thousands died in minutes. They fell in their lines as enemy fire swept through them. As the intensity of the fire grew, some squads went to ground, scrambling into shell craters for cover, only for more plunging enemy artillery to land amongst them.

Officers urged their platoons onwards, only to be cut down in their turn. Back in the trenches the next squads were assembling, as shells and bullets whined overhead they fixed bayonets and waited their turn in the maelstrom. They did not have long to wait, and with the enemy already manning his positions they climbed up their ladders to be immediately hit, many falling backwards into the trench and onto their comrades below. Few would make even ten yards from the parapet before being forced to ground.

It was pitiless and gruesome. Massacred in their turn, whole platoons were simply annihilated by the intense enemy fire. No-man's land was littered with corpses and the writhing wounded. The survivors were scrambling in the mud, some trying to fall back, others still trying to push forwards. A few squads made it to the enemy lines, charging at the defensive walls, bayonets levels, hurling grenades ahead of them. But even here they were met by an enemy who fought hard, holding their positions to the last man. In sector 469-391 nowhere did any platoon reach the enemy lines. Of 32nd Company's nine platoons, some 600 strong at the outset, 542 were killed or injured in the first wave. Every officer was killed. At roll- call that evening, the 58 survivors were not enough men to constitute a single full strength platoon.

Despite the slaughter ahead of them, in the second line trenches and communication trenches the second wave was preparing for its turn to attack. Amongst the jostling men, grenadier squads lumbered forwards under their heavy armour. The artillery shells rumbled overhead on their way to distant targets of little use to those men now facing an advance into almost certain death. Such it was to be a soldier of the Death Korps. The second wave would walk the same ground over which the first had been all but destroyed.

Right on cue, over the top they went as the plan required. The maelstrom of fire and explosions crashed over the second wave and they added their bodies to the first wave. At the gaps in the wire the dead and wounded lay on top of



each other in a grotesque, groaning, bloody pile of ruined flesh. All day long the slaughter continued, until nightfall saw a halting of the attack. Throughout the night the wounded crawled back over the parapet as the occasional star-shell exploded overhead to reveal a hellish scene. No-man's land was seemingly alive with writhing figures. Some survivors held their positions in no-man's land all night, sporadic firefights flared in the darkness as a brave few still tried to press forwards towards their objectives.

The cost had been horrific. The gains had been negligible. And come dawn it would start again. The endless artillery duel resumed, and shells began to land again, churning the dead into hunks of meat, tossing bodies and body parts with each impact. The third wave would also go in, and it too would pay a heavy toll in blood for no gains. The desired breakthrough never came. The defence lines' construction work had been completed, and if anything, improved upon, and the line held.

At 218813.M41, with the surviving Krieg units now back in their trenches, holding the line, the enemy launched its own counter-attack, hoping to exploit its victory, knowing that the attackers must have been weakened by their heavy losses. It was the traitor's turn to surge out across no-man's land. With no preliminary bombardment, so as to avoid forewarning the defenders, the enemy's squads, many riding in Chimera carriers attacked. The battered men of Krieg

manned their heavy weapons, most of these were still in place having never been committed to the ill-fated assault across no-man's land. All along the line determined fire halted the attack, and the quad- launchers and heavy mortars of the second line quickly adjusted their fire, pinning the enemy down.

At trench line R462-3892 Lieutenant Marot and his ad-hoc survivors, men collected from three devastated platoons of 15th company, 143rd regiment, saw a mass of enemy infantry appear in no-man's land, plainly visible from Marot's command post. A vox-message was relayed back for defensive artillery fire, but produced no barrage of explosives. Despite his squad's lasgun and heavy stubber fire the attackers closed in. Marot lost contact with the units on his flanks. Enemy infantry were close, throwing grenades into his trenches. His men returned in kind. In a fierce fight Marot's platoon was being wiped out piece-meal by overwhelming numbers. He was down to thirty men, then twenty. Now the enemy were jumping down into his trenches. Vicious hand-to-hand fighting with bayonets and rifle butts was his last resort. An unseen chainsword cut took the lieutenant's left arm off, and as he lay mortally wounded, the trench was overrun. The enemy attempted to rush the next section of the line, but found resistance still stubborn. Later, with the enemy halted, a new fire mission request eventually produced a deluge of Earthshaker shells which obliterated their own frontline trenches



*Above: The backbone of each Siege regiment's firepower – the heavy artillery. Once positioned, each gun might remain in position for months, maybe years on end.*

and smashed the enemy's foothold in the Krieg lines.

By nightfall the enemy attack had spent itself, their dead piled on top of the men of Krieg. The opposing sides were again at stalemate. The artillery duel continued, but the fury of three days of battle had subsided.

#### **Life in the Trenches**

All along the line, both sides dug themselves in deeper. The Krieg trench lines expanded backwards. Third and fourth lines were added, gun positions were improved, the frontlines were heavily reinforced. Systematically, a maze of trenches spread across the Van Meersland Wastes. It seemed neither side was planning on moving for a long time. The 149th regiment's abortive attack was just the first of countless similar attacks to follow. Each regiment would take its turn to brave the killing fields of no-man's land. Each regiment would be repulsed. At Hill 204, the 308th regiment gained a foothold in the defence line during 34th korps' offensive in the Saritama Hills. They held the high ground for weeks before repeated enemy counter-attacks forced them to withdraw.

For weeks on end the stalemate held each side firmly in position, sentries staring out across the desolation of no-man's land at the enemy positions. Despite the stalemate every unit would still have to take its turn at patrolling and

raiding the enemy lines. Night operations in no-man's land saw patrols finding or laying minefields, or identifying gaps in the wire for a subsequent raid to exploit. Trench raids to take enemy prisoners were common. Prisoners could be interrogated for information about troop numbers and positions. The artillery continued its endless battle, and all day long both sides fired harassing shots into the enemy rear. Death could come suddenly anywhere within range. Even during the quiet periods, when neither side was attacking, the casualty lists continued to grow rapidly. 88th Siege army was losing an average of 2,000 men a day, without any regiment actually launching an attack. Of course the losses had all been planned for, and for the Krieg regiments, the replacements kept arriving to re-fill the ranks.

Life in the trenches saw guardsmen living like rodents, crowded into dim, dank underground dugouts. Those on duty stood sentry in the trenches and watched for any enemy activity. The daily storms and downpours of Vraks' volatile climate turned trenches into running streams and no-man's land into a swamp. Soon the rainwater would drain away, leaving behind a sticky quagmire of grey mud. For troops approaching the frontline it seemed like they were entering a giant furnace that ceased neither night or day. The constant roar of guns and explosions rolled out across the Van Meersland

Wastes. At night the sky was ablaze with the fire of explosions and the stark glare of star-shells. The closer one approached the front, the denser the shell holes became, and more bodies and wrecked equipment lay abandoned in the mud. Amongst the corpses moved the Quartermasters and their aides, gathering any salvageable equipment, stripping the corpses of uniforms, weapons and supplies, all to be returned to the logistics pool and re-issued to new arrivals. What was a single body to these grim figures? A chance to update the supply lists with far more important items than easily replaceable flesh.

Vraks was a wasteland of monochromatic gloom, grey and black, overcast with a pall of smoke that blocked out the sun's light. The air was filled with the thickening stench of putrefaction. Where attacks had failed, the unburied dead lay everywhere, because under the non-stop shelling any attempt to recover bodies often just resulted in more dead. The stinking corpses were rotting away. Day after day the heavy guns pounded the dead, until whole bodies were quartered and quartered again. No-man's land was filled with dismembered stinking fragments that had once been men. Shell holes exposed the remains of decomposing soldiers. Soon both sides were mounting skulls and bones on their positions as macabre shrines to their sacrifices. Death surrounded them. As the months of stalemate passed, the air and the very ground became poisonous with infection.

So the first year of the siege slipped past. The outer defence lines had held against the first assaults, and both sides must content themselves with wearing down the other. One day something, somewhere, must give, but until then the armies were locked in a grinding stalemate of slow destruction.

#### **The Battle of Fort A-453**

At 897814.M41 the 261st regiment was ordered to conduct a probing attack in sector 45-49. 30th line korps had been probing along its entire front in anticipation of a renewed offensive after six months of relative inactivity. The korps had been given time to build up its strength after early losses, and the guns of 19th bombard korps were beginning to be repositioned to support the new offensive. 9th company had been given the difficult task of attacking a strong point in the enemy line, designated fort A-453.

A-453 was a strong position of interlinked bunkers and pillboxes, but its main weaponry, a casemate-mounted

Earthshaker cannon, had already been destroyed by a direct hit from a Bombard siege shell. Still, the battered pillboxes bristled with heavy bolters, each with interlocking fields of fire out across no-man's land. It was surrounded by an anti-tank ditch, mines and thick bands of razorwire, and underneath the bunkers lay reinforced personnel shelters and stores for the garrisoning troops, all approachable in safety via an underground tunnel that ran back for half a mile. One previous attack on fort A-453 had been easily repulsed.

In darkness the commander of 9th company, Captain Tyborc, saw to the final preparations of his men. At first light he would lead the attack, whilst higher ranking officers observed from a safe distance to gauge the fort's strength. A battery of thudd-guns had been dragged forward to engage the fort over open sights as his men crossed no-man's land. Over the past weeks, a new trench had been excavated to facilitate the advance. His men had only three hundred yards to cover to reach the relative safety of the fort's anti-tank ditch.

It was still dark as the attack's preliminary bombardment started. Heavy shells screamed just overhead, pounding the invisible fortress. Amidst the staccato flash of explosions, Tyborc's leading platoon crowded into the forward trench ready to attack. Light was just showing over the horizon when the barrage lifted and Tyborc ordered the attack to commence. He was the first to climb the ladder.

The bombardment had left no-man's land shrouded in smoke, and at first the attack covered the open ground quickly. After the first hundred yards the enemy had not responded. Tyborc urged 9th company on, gathering pace as the enemy razorwire approached. Then a heavy bolter barked. Suddenly 9th company were under fire. Ducking through the fire that whipped around them, Tyborc's squads pressed on, and reached the wire. Frantically they worked with wire cutters as explosive bolter shells flashed above them. Further back other squads were taking casualties and becoming pinned down in the same fashion. But at the front the captain and his command squad rolled under the wire and plunged down into the anti-tank ditch.

Despite the mounting casualties, 9th company was swarming forwards in their captain's wake. More men were at the wire, cutting gaps and diving down into the ditch. Climbing the ditch's steep

glacis men started to step on mines. The defenders had protected the ditch against enemy infantry. Tyborc's men were trapped. They could fall back across no-man's land through enemy fire or risk the mines. Tyborc waved them on, regardless of casualties, and to set the example ran up the slope. Mines were exploding left and right, but Tyborc reached the top, and others followed. Ahead of him a pillbox continued to fire, and as the men emerged they were raked with bolter shells. The captain was wounded in the leg by a shard of bone as the guardsman next to him vanished in a welter of blood, the bolter's warhead tearing him apart from within. Staggering onwards Tyborc indicated for his men to assault the pillbox.

By now the defenders were responding to the surprise attack. Emerging from their overnight shelters to find Krieg guardsmen already inside the wire some of the defenders raced forwards, charging the attackers and hand-to-hand fighting was suddenly spreading through the fort. Others saw the attackers at close quarters and turned and ran, believing the position already lost.

Suddenly the fort was in chaos and confusion. Quad-launcher rounds began to land, killing both sides indiscriminately. Tyborc was wounded again by shrapnel as his men swarmed over the first pillbox, posting grenades through the firing slits to kill the gunners inside. He had a slim foothold inside the strongpoint. He needed to hold it. Bleeding heavily, the captain took cover behind an overturned barricade of

rock-filled fuel drums and sandbags. All around him his men were firing at the emerging defenders. Somewhere in the confusion of the charge he had lost his vox-caster operator, no doubt the man was already lying dead somewhere. 9th company needed reinforcements to hold the ground they had captured. Tyborc summoned a runner to take a message back: "9th company within wire. Enemy in growing strength. Will hold if reinforced." The runner scurried away.

For an agonising hour Tyborc's men fought their isolated battle. A second pillbox was turned into smoking ruin by a flamer. By now his men were occupying some of the enemy trenches and working their way towards the central bunker. They captured an entrance to a personnel shelter and, after a melta-gun blasted the steel door into molten metal, Tyborc led them down the ferrocrete steps into the bunker below. He was faced by a long gallery across which hastily erected barricades had been built. Las shots flashed in the dim light, bullets ricocheted off the walls. Tyborc, still limping, ordered those with him to charge. They rushed the few defenders, bayonets levelled, and cleared the gallery. Tyborc was wounded for a third time, taking a head wound from an enemy bullet, but his now shattered helmet had saved his life.

Tyborc's men cleared the gallery just in time. Outside, the rising shriek of incoming heavy shells could be heard. The enemy had called for artillery fire inside its own position. On the surface the ground erupted as the pre-sighted salvo scored a direct hit. It was slaughter,



Above: A Krieg infantry squad 'bomb-out' an enemy trench with grenades, supported by a Hellhound flamethrower tank.



Above: Lemman Russes of the 61st Tank regiment attack Fort A-453 during the breakthrough of the outer defence lines.



Above: A poisonous smog hangs over the heavy mortars of the 29th Field artillery company Of the 261st regiment.



those caught in the maelstrom were obliterated. Underground, Tyborc and some forty men were safe.

The massive artillery bombardment ended the battle above ground, the continuing barrage sent everybody to ground. Tyborc's stragglers held the gallery, but, as night fell, no reinforcements came. Obviously the runner had not made it back. The 9th company's survivors would just have to hang on to its hard won gains and hope.

Unknown to the gallant captain and his men his runner had reached their own line. It had taken him several hours to get back across no-man's land, crawling from shell hole to shell hole under enemy fire. On his journey he had been wounded, but blood splattered and covered in mud from helmet to boots, the runner stood to attention and presented the message to General Durjan as the General stood surveying the battlefield from his own command post.

Here was news of a foothold, a chance of a crack in the enemy lines. The General was quickly dictating new orders to his vox-operators. Grenadier units would follow 9th company as soon as they were ready. Tyborc needed a curtain of artillery fire to cut off the fort from enemy reinforcements. Immediate diversionary attacks should be launched all along the regiment's line, to tie down the enemy. Most importantly, he needed a breakthrough force to strike quickly.

Early the next day grenadier units were working their way towards the fort, still under heavy artillery fire. Meanwhile Tyborc's men fought a ferocious close quarters struggle in the galleries and corridors underneath A-453. In pitch darkness, illuminated only by the flash of exploding grenades, they held on. The enemy had been reinforced via the access tunnel, but they could not break into Tyborc's gallery. The air was thick

with dust and the fumes of explosives. Without their respirators the guardsmen could not have survived. Tyborc's men looted the enemy dead for weapons as their own ammunition and grenades ran out. They barricaded the doorways and held them until their defenders were hit, and then others would immediately replace them. The defenders used the bodies of their own dead to add to the barricades. Tyborc was down to just sixteen men, but throughout the day, as artillery rounds drummed on the earth above, sending more dust cascading down onto them, Tyborc valiantly fought on. By nightfall the grenadiers had cleared the remaining surface structures and were fighting to gain access to the underground shelters.

The third day of the battle was to be the turning point. With fort A-453 almost in Krieg hands, they had a crack in the enemy lines. The enemy would counter-attack furiously to recover it. But General Durjan had secured the release of three companies of the 61st Tank regiment from reserve along

with a Baneblade heavy tank and now he threw them into the battle around the fort. The Leman Russes and the Baneblade rumbled forwards through the continued barrage of enemy shells. The tank column was accompanied by Atlas Excavators, each equipped with a dozer-blade to fill in the anti-tank ditch and allow the tanks to cross. It took most of the morning, and the loss of four Atlases for the ditch to be filled. The Baneblade and Leman Russes ploughed forwards, smashing aside the razorwire cordon to join the infantry and grenadiers holding the ruins. Together they would push onwards. The dam was breaking, General Durjan threw more men into the breach. All along 30th Korps's front the Death Korps were now furiously attacking.

The third day underground for Tyborc was the longest and grimmest. The enemy attacked with flamers, trying to burn him out. He had no such weapons to respond with. Asphyxiating black smoke filled the corridors. Tyborc was down to his last respirator filter, when it failed, the atmosphere down there would kill him. His water supply was out, his laspistol showed empty. He had new wounds to his legs and stomach. Pinned into one gallery the end would be soon. Following the flame-thrower attack the enemy rushed the gallery again. They were cut down at the doorway by lasgun fire and grenades. Quickly the Kriegsmen dashed forwards and looted the enemy bodies. One of the dead was still carrying his flamer, the fuel canister half full. They ran back to their barricades before the enemy attacked again. The flame-thrower would seal the entrance in a sheet of



burning promethium and prevent any enemy break-in until it too ran out of fuel.

That night the battle above ground was still raging. Unknown to Tyborc the grenadiers had forced a way into the underground complex and, after heavy losses, now held the main access tunnel. They had quickly set demolition charges should the enemy threaten to retake it. But corridor by corridor the remaining grenadiers were clearing the complex. Just before dawn a grenadier watchmaster signalled he had found survivors. They were held-up in a gallery. The grenadier squad had narrowly avoided being attacked before establishing they were friendly forces.

Captain Tyborc staggered from his bolthole wounds in both legs, his right arm, abdomen and head, and with just eight wounded men still under his command. He was carrying a flamer with an empty fuel canister, his uniform was ragged and scorched, his helmet shattered. But he was alive and the fort had been captured.

**The First Breakthrough**

The 30th line korps pressed hard. More men and tanks were funnelled into the breakthrough at fort A-453, widening the gap. The enemy had to direct forces from other sectors in an attempt to stem the tide, leaving them dangerously low on men. Suddenly, where there had once been an endless stalemate, the Death Korps was advancing. Over the next ten days the battle raged above ground. Briefly, this was no longer a grinding trench war, but fighting in the open ground. The Death Korps tanks pushed eastwards, and the enemy threw repeated attacks at them. The wastelands were littered with the detritus

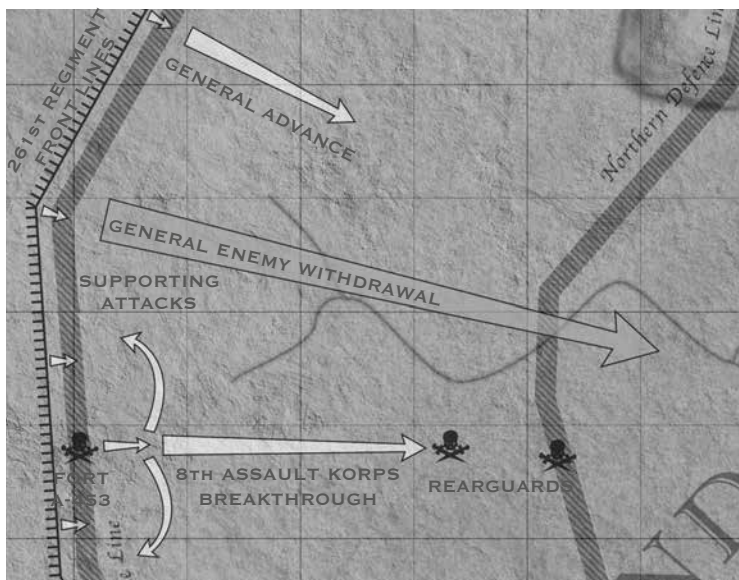

The 261st regiment's breakthrough at Fort A-453, and 8th assault korps' exploitation. The enemy did not hold the next defence lines, except with rearguard actions.

of battle, burned-out wrecks, abandoned artillery guns and weapons as the breakthrough gradually forced its way eastwards. The 8th assault korps was through the breach and turned north and south to roll up the outer defence lines. The defensive positions were designed to face outwards and suddenly, out-flanked or attacked from behind, the positions were no longer tenable.

Enemy units started to abandon their defences and move back. They knew that there was a second line to fall back to, and quickly did so, seeking the shelter of the new defences. Where the 30th line korps had led, the neighbouring 12th line korps soon followed. Its men surged forward and swarmed over no-man's land, once the killing fields, now only defended by a few ill-fated rearguard units. Soon after the 34th line korps also broke through in the Saritama Hills. Death Rider companies pursuing the enemy hard as they fell back en masse. Behind

the cavalry, infantry companies were advancing in unopposed columns. After two years of bitter attritional warfare, the first defence line had fallen, collapsed like a house of cards. There was still mopping up to complete, as rearguards fought isolated actions to hold up the advance, until they too were overrun and wiped out. The cost in men was as yet uncounted, but the first objective of the siege of Vraks had been completed.



Opposite Top: An autocannon crew in a front line trench keeps watch over no-man's land.

Opposite Bottom: A Centaur carrying an infantry command squad moves forwards during the breakthrough.

Left: A Gorgon rumbles past a covering lascannon team on its way to the front.



A Gorgon heavy assault transporter of the 179th Krieg regiment, 8th assault corps.



A Gorgon heavy assault transporter of the 7th Tank regiment, attached to the 143rd regiment.

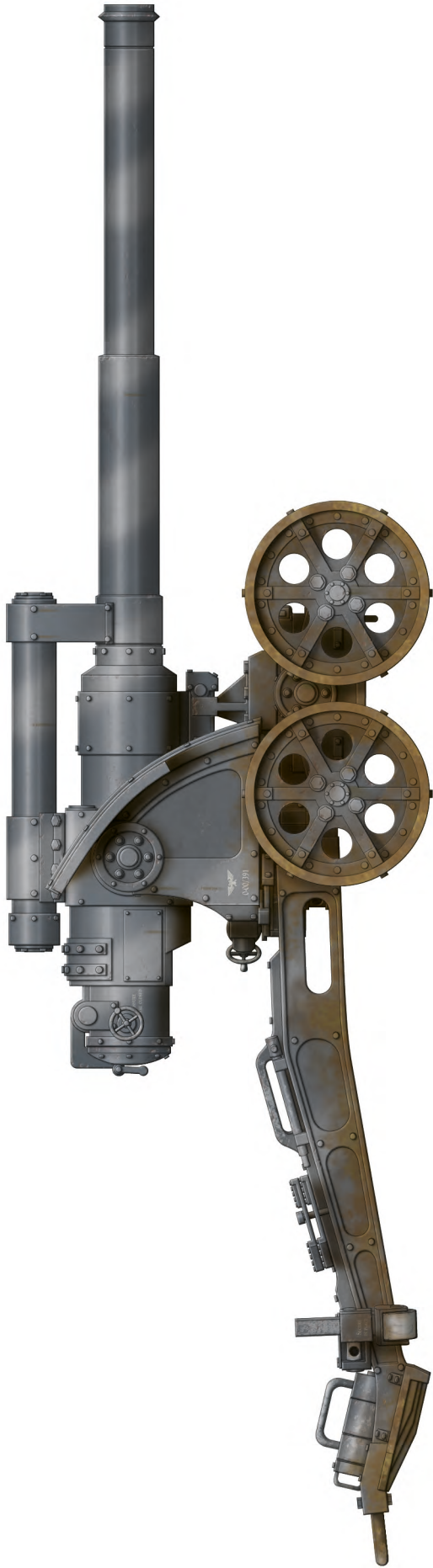

An Earthshaker cannon of the 45th Artillery company, 143rd regiment.

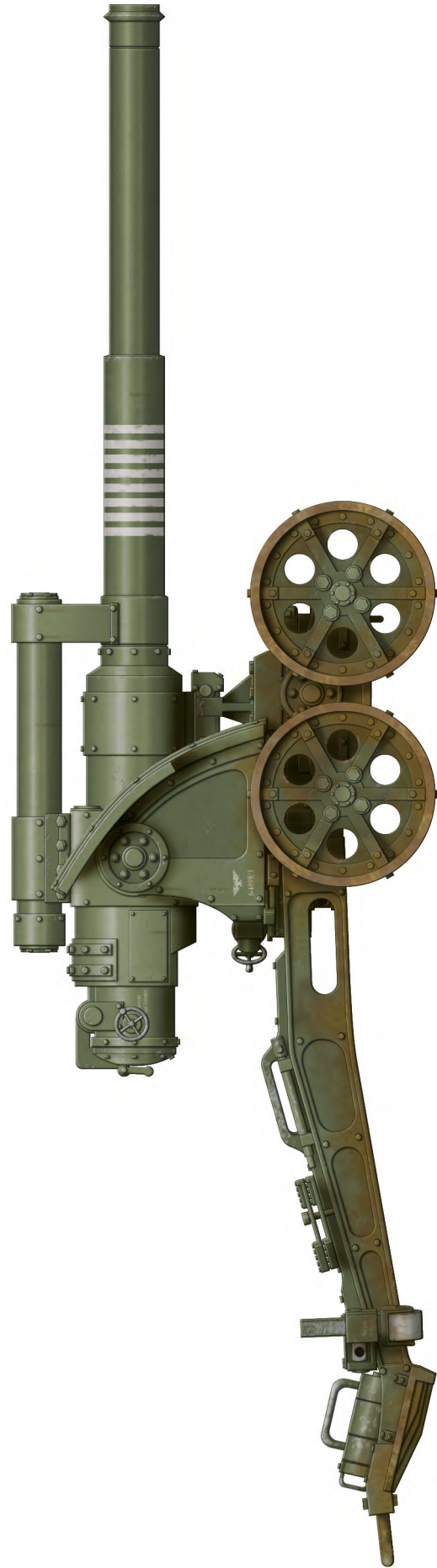

An Earthshaker cannon of the 4th Independent Artillery company, attached to various regiments during the campaign.

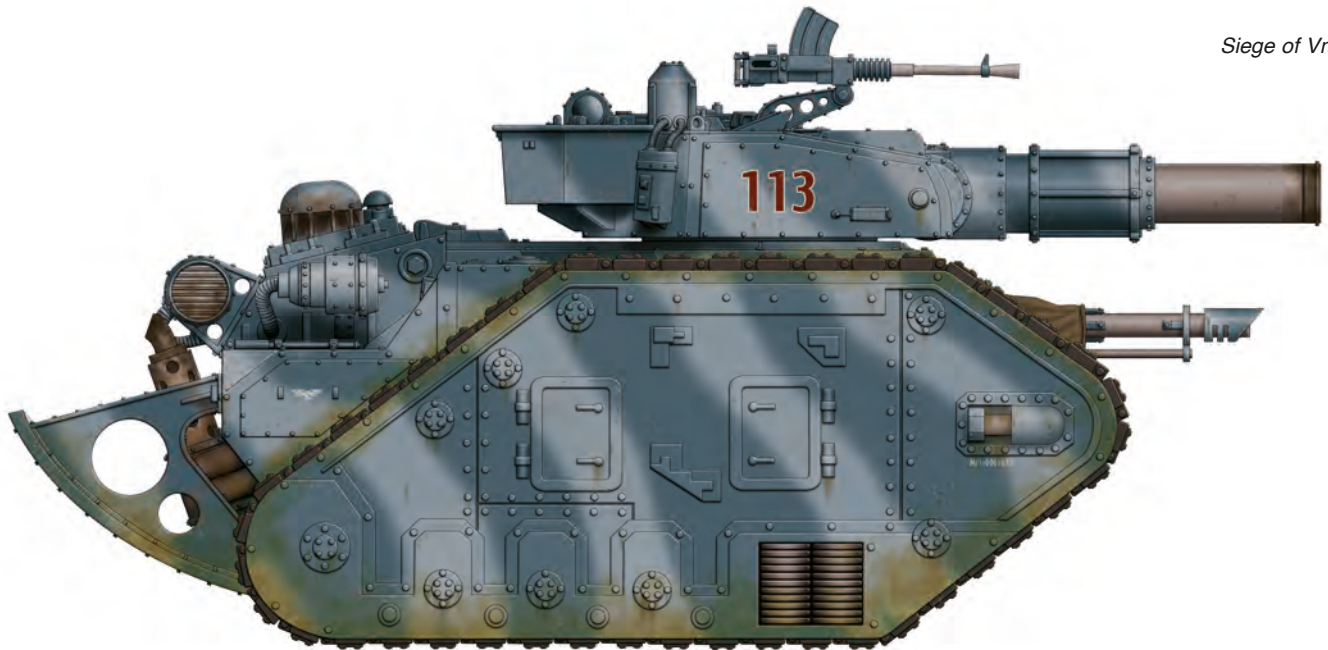

Leman Russ of the 61st Tank regiment. Third vehicle of first company, first squadron. Note the replacement battlecannon barrel.

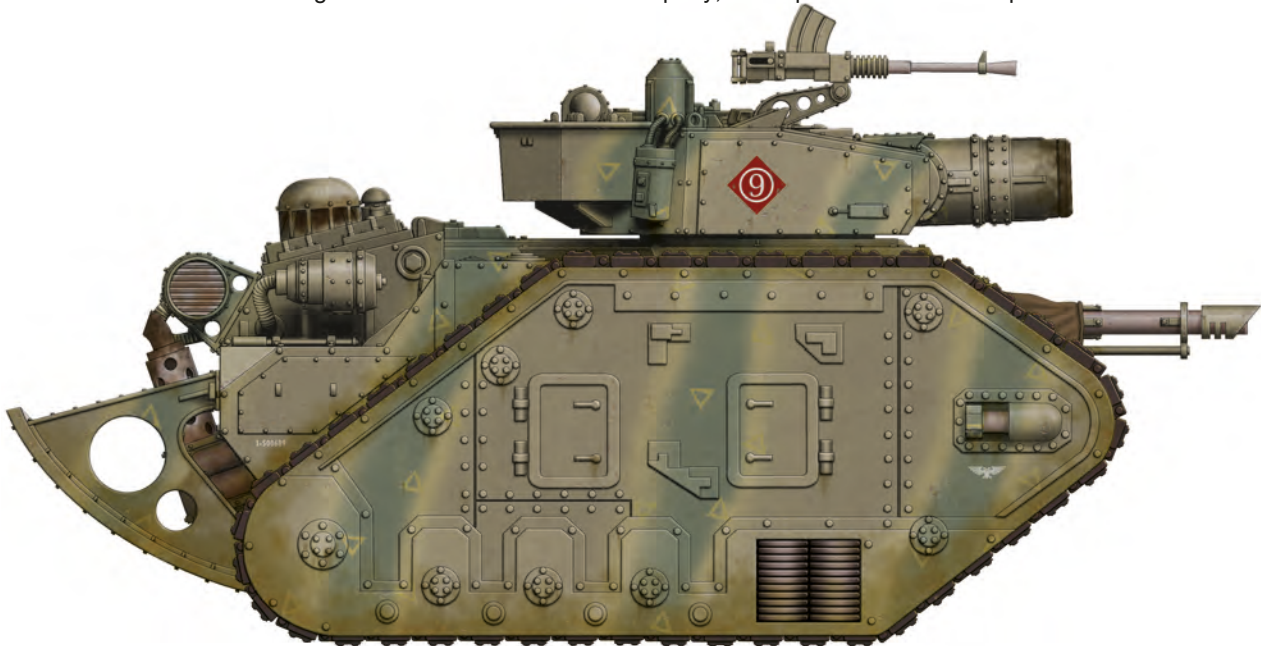

Leman Russ Demolisher of the 7th Tank regiment, 1st company, 9th vehicle.

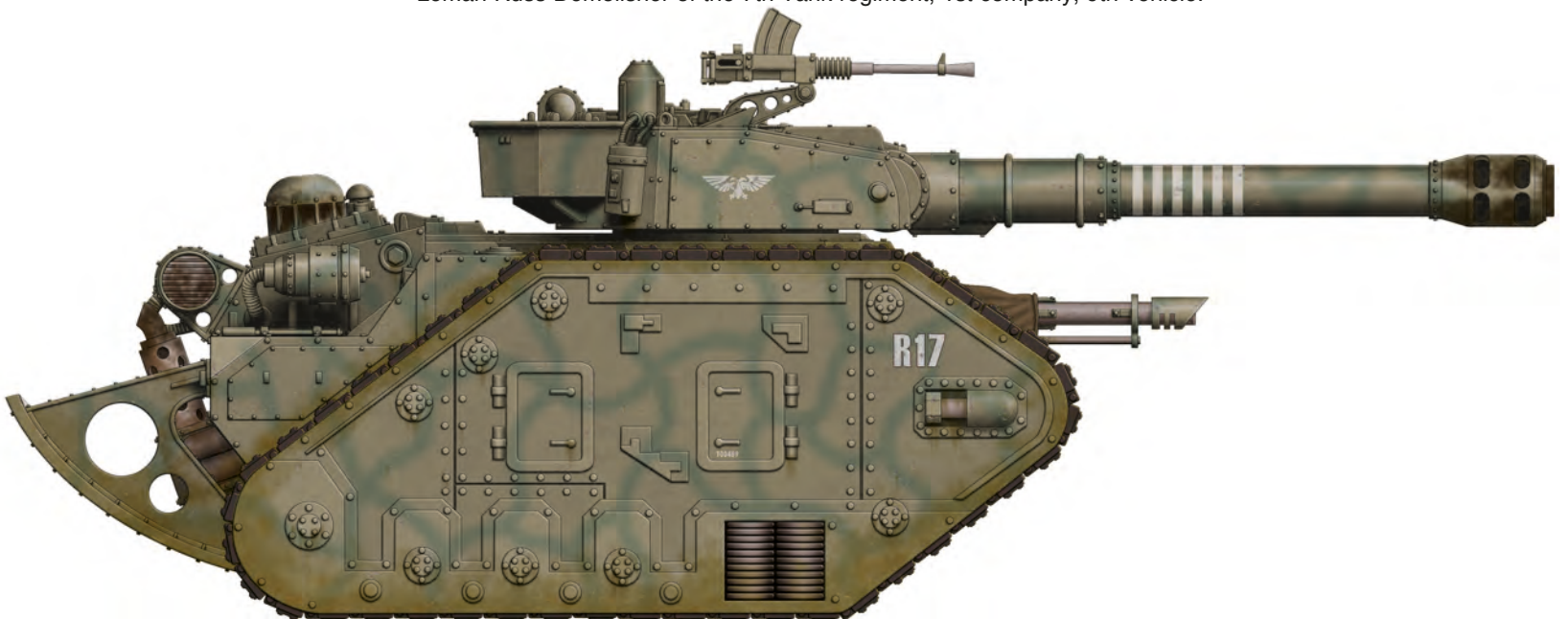

Leman Russ Vanquisher of the 7th Tank regiment. This is the command tank of 17th company.



Heavy mortar and Centaur carrier of the 143rd regiment, 1st Field artillery company, C battery.

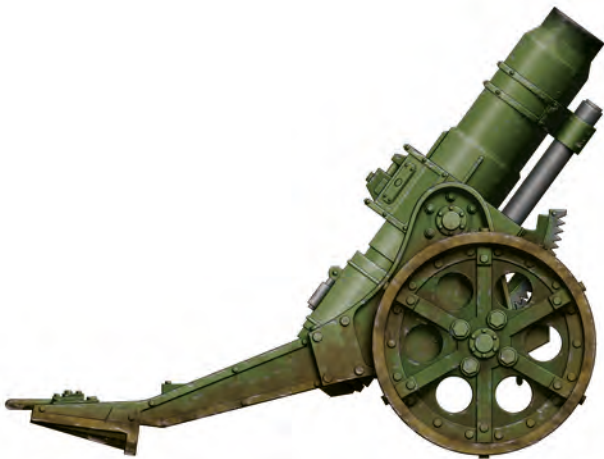

Heavy mortar of the 19th regiment, 38th Field artillery company.

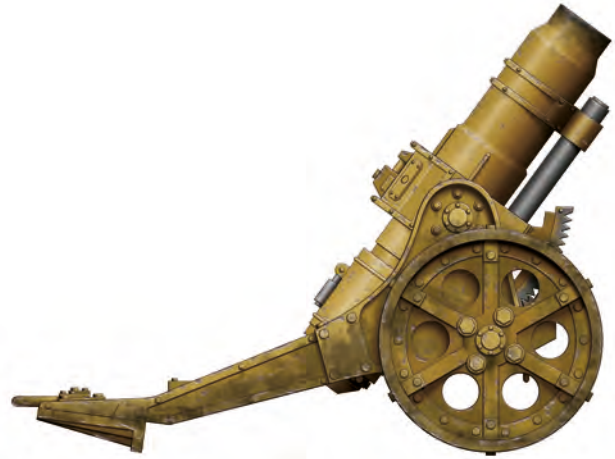

Heavy Mortar of the 261st regiment, 8th Field artillery company.



Centaur carrier of the 19th regiment.



Heavy quad-launcher and Centaur carrier of the 143rd regiment, 1st Field artillery company, B battery.



Heavy quad-launcher of the 19th regiment, 2nd Field artillery company.

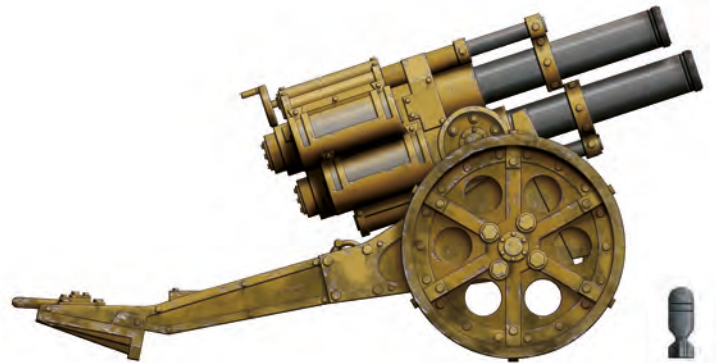

Heavy quad-launcher of the 33rd Independent Artillery company. Also shown is a standard high-explosive bomb.



Centaur carrier of the 143rd regiment, 207th Artillery company. This is the company commander's transport vehicle.

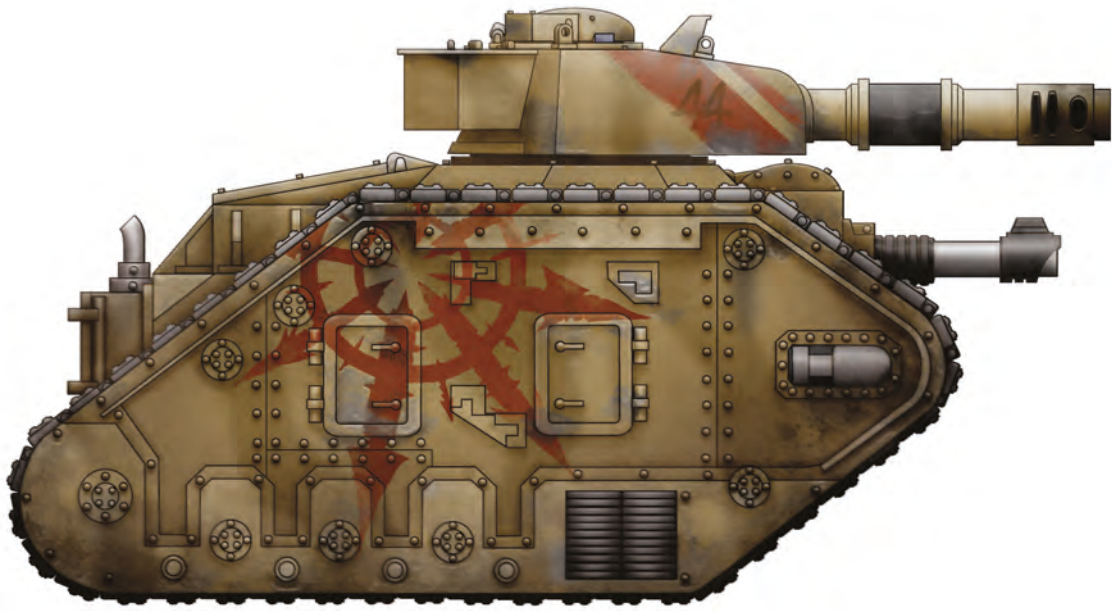

Captured Leman Russ in enemy service. The 44 has been crudely applied along with the heretical symbol.

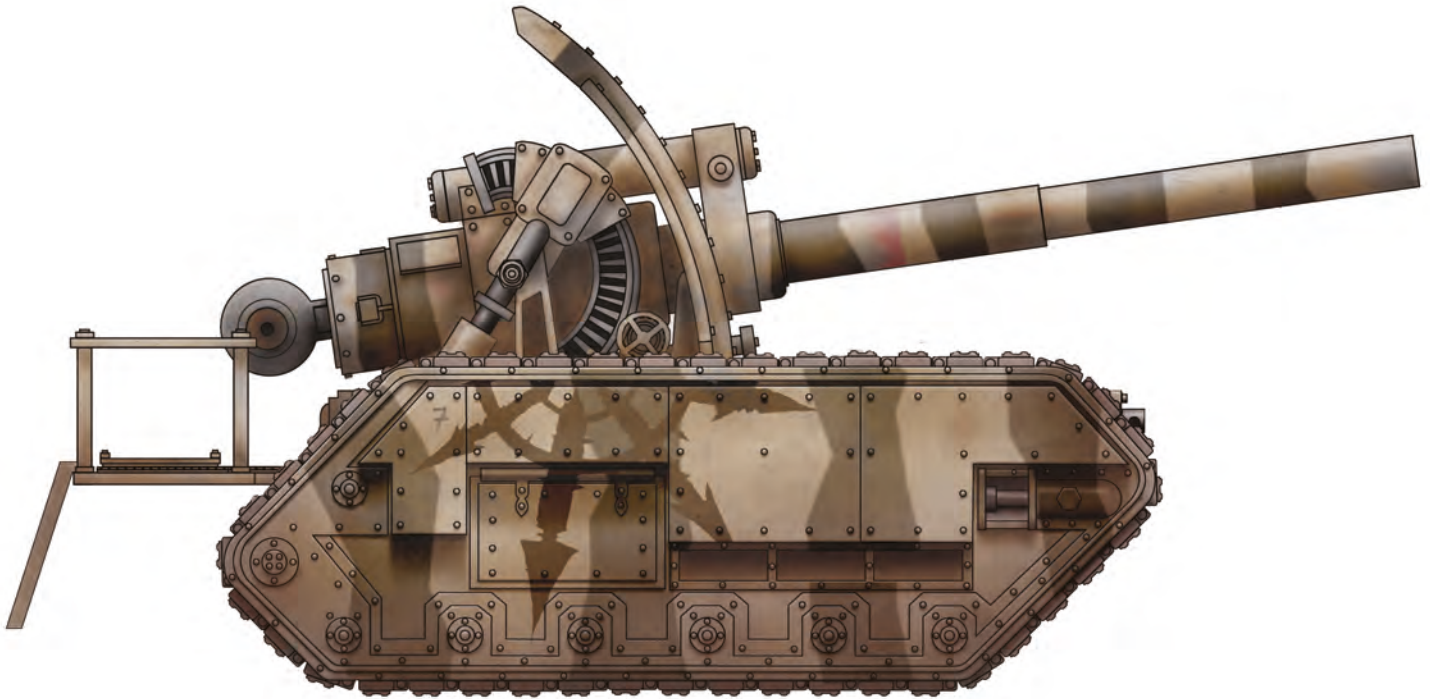

Captured Basilisk in enemy service. It retains its original camouflage scheme.

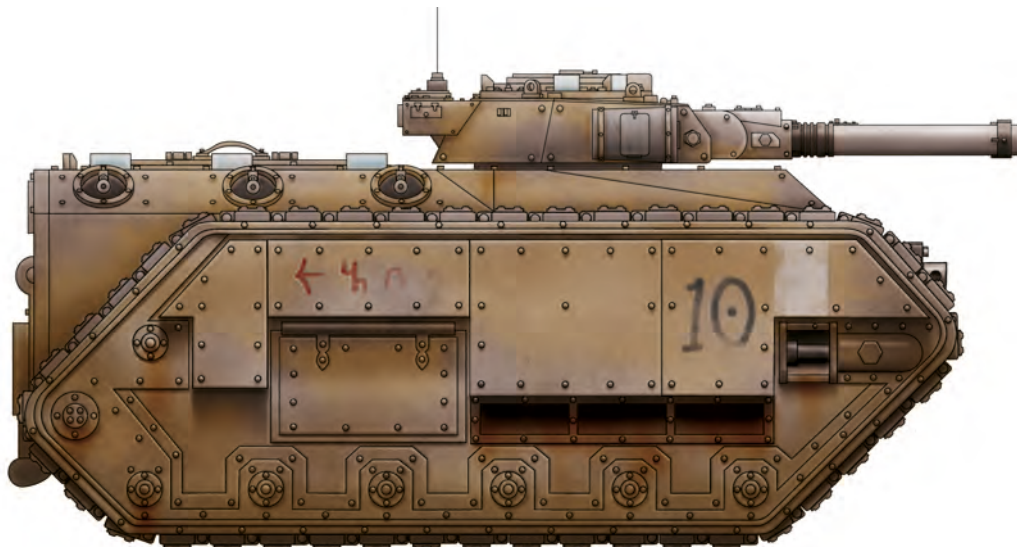

Chimera armed with an autocannon. This vehicle was destroyed during a counter-attack in sector 46-38.

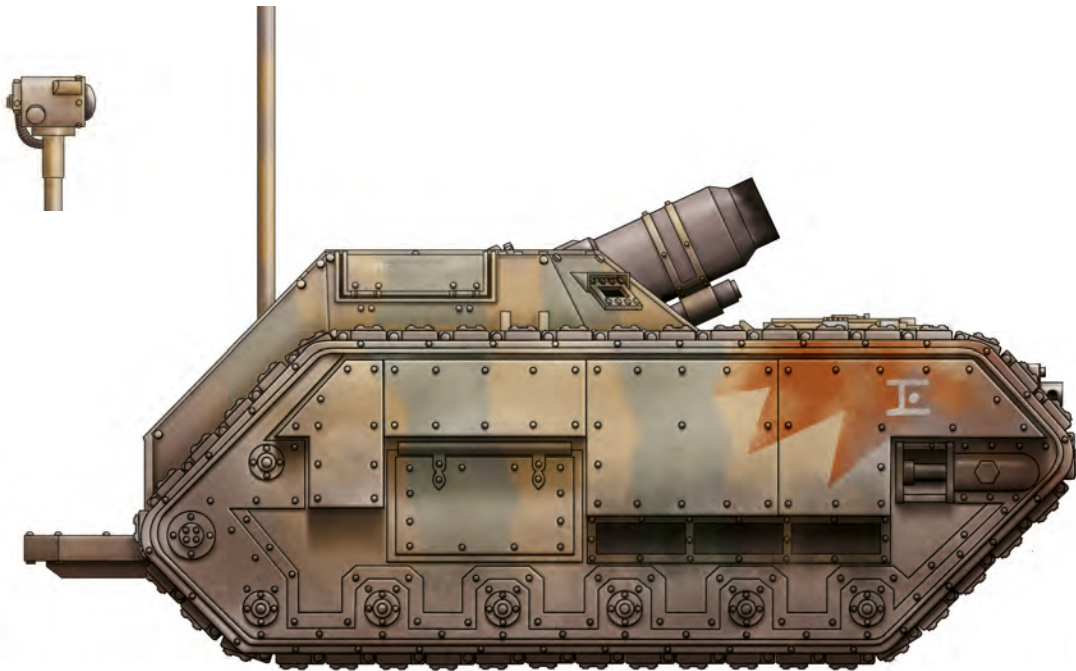

Captured Griffon mortar carrier. Additional recognition markings have been applied over its original colour scheme. The Griffon's targeter is inset.

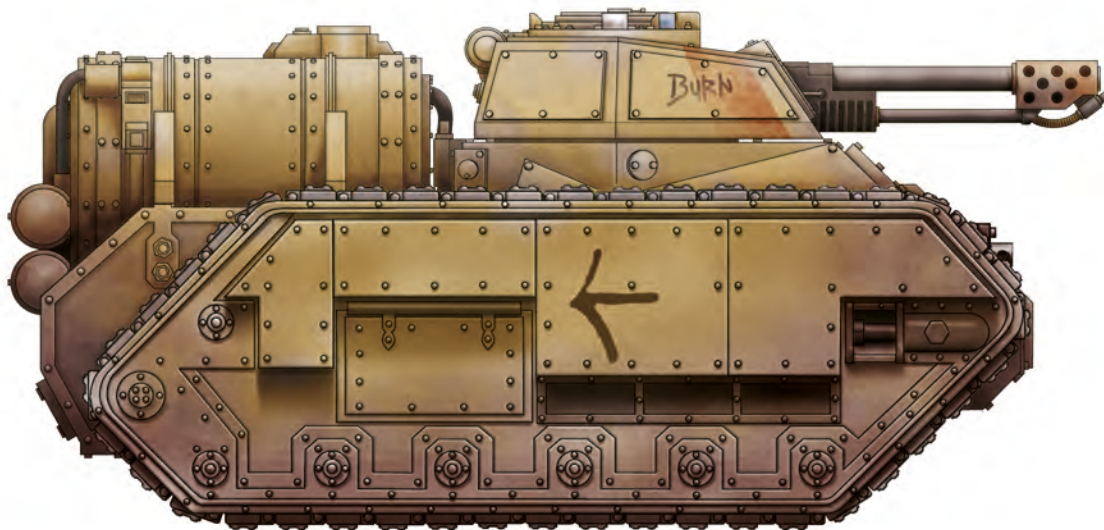

Hellhound flamethrower tank. This vehicle proved popular with both sides during the siege.

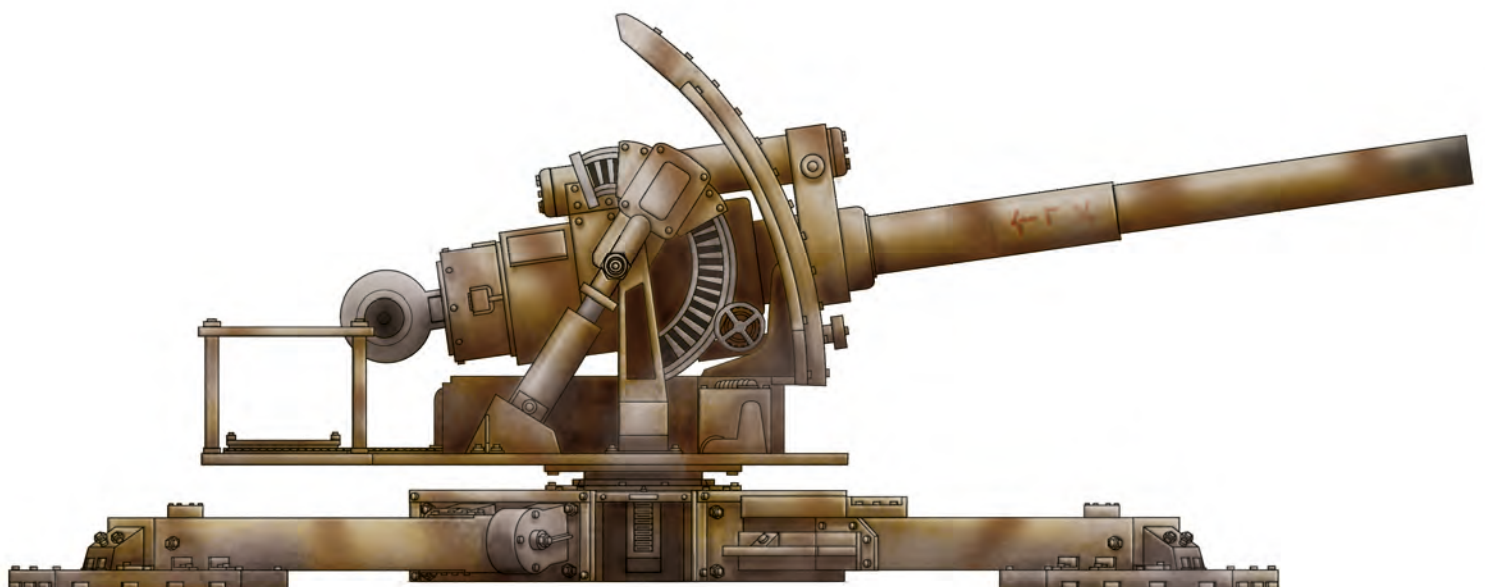

Earthshaker platform. Many of these artillery pieces were added to the defender's Basilisk companies.

# CHAPTER FOUR WAR OF ATTRITION

*“The Krieg method of war is a measure of their discipline and their sacrifice. It demands respect from all – friend and foe alike.”*

Lord Commander Militant, Segmentum Obscurus.

## The Crisis of 1st Korps

With the Krieg breakthrough, the enemy had abandoned not only its outer defence lines, but also the northern line, itself a spur of the second defence line, now felt to be undefendable due to the situation on the ground. It was outflanked to the south, and faced by the Krieg 1st and 30th line korps, which after a period of recuperation were both now ready to attack again. Pinned by enemy attacks to the front, any defenders could quickly be cut-off by the advance of 12th line korps. If the defenders stood firm then it would only be a matter of time until they were surrounded and lost. Instead of risking a catastrophic defeat by holding onto untenable ground, the defenders withdrew further.

The 1st and 30th line korps found the northern defence lines abandoned, and were soon pushing forwards against only light resistance from rearguards, snipers and the inevitable harassing artillery fire. The 1st Korps swung eastwards, in the direction of hab-zone 1, which lay astride one of the main routes between the citadel and the star port. As 1st line korps moved south and eastwards, it was also encircling the second defence line.

So far, in over two years of war, the 88th Siege army had been constantly on the attack – with the Vraksian rebels willing to hold their positions and fight

a defensive war, except when required to launch counter-attacks to retake lost ground or spoiling raids into the enemy lines. At 255815.M41 this strategic situation changed. As the 1st line korps closed in from the north towards the second defence line, it was to be subjected to the enemy’s first concerted offensive of the war.

The northern defence line might have been abandoned without a fight, but the ground between the two positions had been identified as the scene of a strong counter-attack. The defenders had mustered a substantial armoured reserve at hab-zone 1. Leman Russes, Chimeras, Basilisks and Griffons had all been husbanded there, along with crews in order to conduct the counter-attack – catching the Krieg regiments of 1st korps whilst they were out of their well defended trenches, marching over open ground.

The 19th Siege regiment was occupying overnight positions in sector 60-53. Its forward sentries reported hearing the movement of enemy vehicles throughout the night, and, in response, harassing artillery fire was increased in an attempt to impede whatever the enemy were planning. Expecting a local counter-attack the forward companies were reinforced, and a general stand-to was issued at dawn. The newly dug trenches (in most places no more than

a shallow ditch) were lined with men, lasguns at the ready.

First came the enemy shells, a ranging shell here or there, before the tornado descended upon them. A mass of concentrated artillery fire thundered over the 19th regiment’s positions, rolling and booming like a sea during a storm. Amongst the heavy shelling came smoke shells, spouting thick white clouds that obscured the battlefield. Behind the smoke came the first wave of enemy attacks. Drivers shifted into gear and the tanks and armoured carriers rolled forwards across the rolling wasteland. Behind them the sun was just breaking the horizon, a pale orb through the dust clouds thrown up in the attacker’s wake. As the attackers approached, the artillery fire ceased.

Through dust and smoke the growing noise of approaching engines sounded like the forges of hell had opened. Tank shells flew into the front trenches, a series of explosions that tore bloody gaps in the crowded trench lines. Reports of squadrons of enemy tanks and Chimeras were being reported all along 19th regiment’s front. As the enemy closed in, the infantry riding inside Chimeras and on the rear decks of the tanks disembarked. They yelled out their godless battle-cries and swarmed forward, bayonets fixed, knives, axes and fighting blades in hand. They charged forwards recklessly as the Krieg guardsmen returned fire with lasguns, heavy stubbers and heavy bolters. They blazed away into the attackers, but the tank fire was destroying the trenches piecemeal. Tonnes of earth collapsed inward, burying men alive as whole squads vanished in the growing maelstrom of flame and shrapnel. The enemy were like rabid dogs, hunting in packs as bullets and tank shells sheeted across the wastelands.

One after another, Krieg units were overrun, and onwards thundered the enemy tanks. B battery, 22nd Field artillery company’s four quad-launchers were firing over open sights at the approaching enemy, until they received an order to withdraw. As the Centaur carriers came forward to hitch up the guns, they were engulfed in a furious

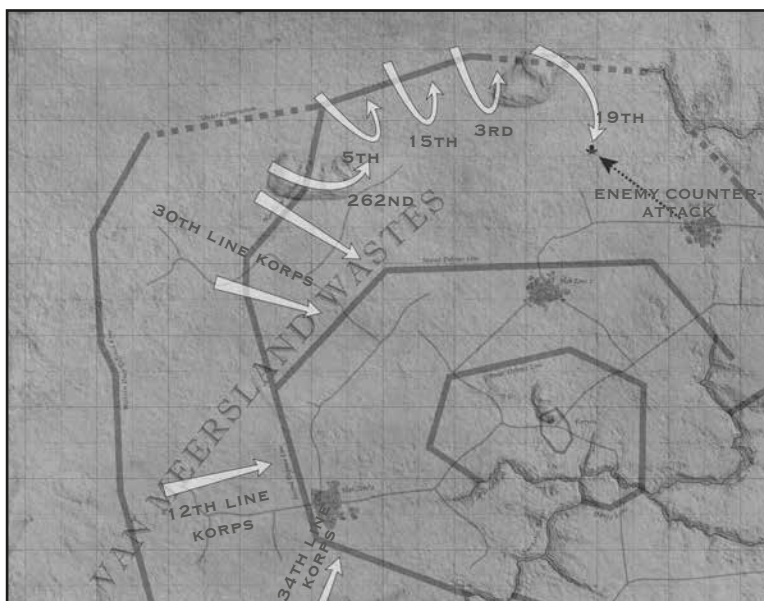

*Advance to the second defence line, the enemy counter-attack and the withdrawal of 1st line korps regiments.*



*Top: Krieg infantry storm forwards through the inferno of battle.  
Bottom: Tanks of the 7th regiment in action in no-man's land.*

barrage; two guns and three carriers were destroyed in an instant. A third gun had to be abandoned, but not before a Krak grenade was dropped down each barrel to sabotage the weapon. The last gun of the battery bounced away behind its carrier as tank shells exploded around it and enemy infantry were already occupying their abandoned firing positions.

Watching through his magnoculars from his command post, Colonel Adal, commander of the 19th regiment could make out the fighting through the drifting smoke and dust thrown up by the bombardment. Reports of positions being overrun were already being received, and as he watched he saw enemy tanks engaging and destroying his forward positions. Adal ordered his reserve companies into the line to try to stem the tide. The enemy's momentum had to be stopped. Adal also requested reinforcements from his Korps commander. His lines were under heavy attack by armour, and the enemy had already smashed his front lines and were pouring in their own reinforcements. He needed men, artillery and tanks from the Korps reserve if he was to hold. Failing that he would seek to pull back and establish a new defensive line.

The reply came from higher command. No reinforcements were available, he must hold his ground with the forces at his disposal. There could be no withdrawals. But the pressure on his lines was building, and Adal knew that with the loss of the second trenches, he would be forced to withdraw or face the prospect of an enemy breakthrough. Husbanding the companies still not engaged, he quickly made a new line centred on his own command post.

The fighting continued all day and by mid afternoon murderous artillery fire had started again from both sides. The attackers and defenders had become intermingled. One smashed trench was held by one side, whilst the next was held by the other. In the confusion the enemy held fast, with their tanks in close support. First they held against Adal's artillery fire, and then began again to creep forwards again. During the day nineteen quad-launcher and heavy mortar positions had been overrun, and in many cases the enemy turned the guns around, using them until the ammunition stores were gone. As night approached the fighting subsided, although throughout the night both sides would probe forwards, only to be repulsed. The situation was confused,

there was no longer a clear front line, just a chaotic mess of units.

At dawn the enemy attack was renewed, and again the artillery began to fall. The 19th regiment's own artillery replied in kind, and the big shells streaked overhead as the enemy infantry moved forwards, blood soaked wraiths in the angry dawn light, fighting from trench to trench. Overhead the heavens opened, a sudden lightning storm crashed down, and bands of heavy rain poured down on all, soon the battlefield was a swamp. As the wild winds whipped about them, the enemy tanks pushed onwards. At his command post Colonel Adal watched their approach, and readied his men for their turn. Already enemy artillery fire was landing about him, one shell tore through the roof of his command dug-out, but fortunately the Colonel was not present. He was already out amongst the defenders, observing the fire of the guardsmen around him. Soon the enemy was closing in and the air was thick with bullets and lasgun fire. Tank rounds crashed into the defender's ad-hoc barricades. The first attack was driven off, the Colonel himself, lasgun in hand, firing from behind sandbags. A second attack was also held, but the shallow trenches to the left and right were now in enemy hands, and the Colonel and his defenders were isolated. The Colonel's only escape route now lay over ground swept by enemy fire. His command dug-out was again hit by tank fire, and his second-in-command, Colonel Dyneh, was killed. Adal was down to just eighty men, his communications with the rear were severed. The Colonel issued orders that the wounded were to be evacuated as best they could be, and divided his survivors into two groups. The first unit would break out and take news of the enemy breakthrough back. He would command a rearguard and hold for as long as possible, until either relief arrived or he was overrun and killed. He knew there was little hope of a rescue, but he would fight as long as possible.

The escape group climbed the parapet and headed back, scurrying away as best they could, dodging from crater to crater under enemy fire. Those that escaped passed on the Colonel's report. The Colonel's battered survivors fought on bravely, until the Colonel himself was killed when the enemy brought forwards a Hellhound flamethrower tank to smoke them out. Of his fate nothing was ever known, his body incinerated in the blasts of super-heated promethium that finally destroyed his command post.

With the loss of the command post, the second line had also been breached. The 19th regiment's position was not saveable. They had lost their commander, and there was no longer anybody in a position to co-ordinate the regiment's actions. Isolated groups fought on, but as a cohesive body the 19th regiment was a spent force. Hundreds of stragglers were now streaming back, passing artillery positions where guns were being hitched up to tows and pulled away to safety before the enemy was also upon them. In the chaos of retreat much of the equipment and stores had to be abandoned. It was now up to 1st line korps to salvage what they could from the sudden fury of the enemy assault.

After two days of gruelling fighting the enemy had their breakthrough, and 1st line korps was faced with a crisis. Its entire position was in danger of being compromised by the collapse of the 19th regiment on its left flank. The enemy would soon be around them and rolling up their shallow trench lines. Just as the enemy had earlier fallen back, now it would be the Death Korps' turn to withdraw. Ground that had been so costly to win was going to have to be given up without a fight in favour of a rapid withdrawal to the defensible position of the first defence line. From there the enemy attack could be contained, but it meant moving quickly. First and foremost the enemy attack must be stalled, delayed as long as possible to buy time for the other regiments to re-position themselves. 1st korps gathered elements of the 7th Tank regiment and the surviving Death Rider companies of 19th regiment. These it would throw into the enemy's path in the hope of delaying the advance. It wasn't enough to stop it altogether but any time it bought 1st korps was now vital. Orders were issued to the other regiments to withdraw, whilst 261st regiment would need to turn its flank and dig-in as best it could. The ground lost was a major set back to Lord Zuehlke's campaign timetable.

The effect of the bold counter-attack and breakthrough were felt throughout 88th Siege army. Attacks all along the front were suddenly cancelled, as supplies needed were requisitioned for 1st korps. 8th assault korps was gathered and moved to reinforce 1st korps, to act as a final block against another breakthrough that might see not just valuable ground, but the entire war lost. The enemy had now seized the initiative.

On day three, as the enemy tanks



continued to roll forwards, 1st Korps had at last re-positioned some forces to meet the enemy. It wasn't enough to hold the advance, but these forces would buy time for the avalanche of men, equipment, gun and salvaged stores that were now in headlong retreat northwards. In all, fifty two tanks of the 7th Tank regiment, Lemman Russes and Macharius heavy tanks, had been positioned, against an estimated enemy attack that still had over a hundred, although their numbers were growing all the time if reports were to be believed. The 15th Tank company, consisting of a dozen Lemman Russes was commanded by Captain Gerszon from his own Vanquisher. His squadrons clattered into position as stragglers from 19th regiment streamed back through his firing line. It wasn't long before he spotted enemy tanks to the south. Opening fire at long range he scored a hit, and a cloud of black smoke rose from his target. Watching through his surveyor, the tank commander saw the turret of the enemy tank break apart before flames came boiling up from inside. The enemy pressed forwards, and armour piercing tank shells were streaking back and forth. One shell glanced off Gerszon's turret, another disabled the bow lascannon, leaving the gunner mortally wounded. Gerszon hit two more enemy tanks before being struck for a third time. This time a fuel tank ruptured. Fuel was leaking into his tank, and he ordered his survivors out. The three remaining crew flung open hatches and jumped clear as the fuel ignited, a bright orange fireball roaring into the sky as the Vanquisher was

engulfed in flames. Of twelve tanks under his command, only four were still in action, but Captain Gerszon could count at least sixteen enemy tanks that were now burning. As he ordered the remaining tanks of his unit back, he watched as a squadron of Death Riders, lances lowered, charged forward in a hopeless display of reckless courage. After a day of fighting, withdrawing and fighting again, only nine Krieg Lemman Russes and two Macharius tanks survived, but the enemy had suffered at least as many losses. The armoured thrust had been seriously blunted.

Days of such delaying actions followed, and with each day the enemy captured less ground. After three more days the counter-attack has been stalled, but it had cut a swathe through 1st Korps and forced it to give up much captured ground. 19th Siege regiment had been shredded in the first two days, over eighty thousand men of the regiment had been captured or become casualties, including its commanding officer. Enemy losses had also been heavy, especially in armoured vehicles. The cost of the desperate ordeal 1st Korps had endured would go further than losses in men, material and ground. The narrowly diverted disaster meant that all along the frontline, attacks that should have been weakening the enemy had not taken place. The enemy should have been bled, instead he had grown stronger. He had had time to organise his defences, get guns and reserves into position, and the second defence line would now be a far harder nut to crack.

### **Battles of the Second Defence Line**

After the sudden rush of the breakthrough and the crisis of 1st Korps, the advancing regiments of the remaining three korps were ordered to halt. There could be no headlong charge into the second defence line, but a steady, cautious advance. The second defence line was stronger and thicker than the first, and after his successful counter-attack, the enemy was now occupying it in strength. To attack the defences piecemeal would be to invite defeat. No, the second line must be broken as the first one had, by slow attrition.

The leading infantry companies turned again to their entrenching tools. The Atlas Excavators were again called forwards. The trenches, so recently escaped, had to be dug all over again. The enemy lines would be approached slowly, under the cover of artillery fire. Trenches would be dug forwards, and yard by yard they would close in.

And so the whole gruesome business would start again. The trenches grew, with communication trenches being cut back from the frontline, until they joined with those trenches which had until recently been the front. The Van Meersland Wastes were criss-crossed with a spidery network of trenches, which, day after day, grew into a labyrinth. Those who ventured beyond their particular sector could easily become hopelessly lost. And the ever present artillery harassment began again – the daily threat of sudden, random and unheralded death as mortar and artillery shells exploded without warning, with both sides seeking to make tenancy of their forward positions as difficult and dangerous as possible for the enemy.

At 120816.M41, the 88th Siege army again committed itself to the offensive. An all-out attack was launched by no less than six entire regiments. Day after day the assault continued, at a hideous cost, attacking across a battlefield of shattered bunkers, collapsed trench lines, rusted tangles of razorwire and the exposed bones of the dead, still rotting where they fell. A monotonous, deadly pattern was soon established that would continue across the entire front for months. After hours of saturation bombardment, the Krieg guardsmen would surge forward to attack the enemy's front line, be they trenches, defence lines or interconnected bunkers. In most places the attack would be stalled, leaving the dead lying in piles across no-man's land. In some places the assault would



**1. UNIFORM AND ARMOUR**

The militiaman's uniform is all that remains of his original uniform – the standard two-piece fatigues, tunic and combat trousers indicating that this soldier is was once a member of Vraks' garrison auxilia. Note that the tunic has been defiled with a hand painted heretical symbol – although it is unlikely that the bearer actually realises what this symbol means, and is following instructions from his superiors. Not all militiamen wear the same uniform, many being former members of the labour corps wear work overalls, whilst others wear civilian clothing. This militiaman's boots are standard issue combat boots, with moulded rubber soles and steel toecaps. The boot's greave-plate is

*This is an unknown soldier of the Vraksian militia. There was little standardisation of uniform amongst the defenders of Vraks, and lack of insignia makes it impossible to identify a company, platoon or squad.*

## VRAKSIAN RENEGADE MILITIAMAN

a standard attachment issued to Imperial Guardsmen, no doubt plundered from Vraks' supplies.

Not being front line combat troops, the garrison auxilia were not generally issued with any form of body armour, and this trooper has corrected this with the addition of hand-forged plasteel armour plates. These will provide rudimentary protection in battle, especially in hand-to-hand combat, but also against lasgun impacts. Such items are invariably heavier and more encumbering than actual body armour.

### 2. BREATHING EQUIPMENT

The militiaman's most distinctive piece of equipment is his rebreather. This large piece of equipment has been constructed from air tanks, again scavenged from Vraks' stores, and a hand-sewn gas hood. It is known that all the defenders were instructed to construct such items, most likely because their leaders were planning to utilise prescribed chemical weapons as part of their defensive strategy (chemical weapons were found in considerable numbers in secure deep storage). The rebreather is both a filtration system and an airtight breathing system.

The top cylinder of the backpack is the air tank, and allows the wearer to operate for a limited period in environments where there is no oxygen available. This tank can supply the wearer with air for two to three hours. The lower cylinder is the filtration system, where air from the atmosphere is drawn in, filtered for harmful agents then pumped up the breather hose into the gas hood. Alternatively, if the air is breathable, then both systems can be shut off, and the breather grill on the front of the hood opened, so the user does not have to go through the long process of removing the hood and tanks in battle.

As well as the air hose fittings, the hand-made gas hood has two eye lenses, note that these are positioned further apart than one might expect, this is to allow for greater peripheral vision. Many militiamen modified their gas hoods with a plasteel faceplate for additional protection.

### 3. AUTOGUN

The militiaman's main weapon is his autogun. This weapon will have been looted from the vast stockpiles of small arms stored in Vraks' armouries. The name autogun is a general term covering conventional projectile weapons (ie, they fire a bullet) and, whilst not as common amongst Imperial Guard regiments as lasguns, autoguns are issued in substantial numbers to some regiments. There are many different models and patterns of such weapons manufactured across the Imperium. The simple technology needed to manufacture autoguns makes them common on frontier worlds where contact with the Imperium is infrequent, and also with gang members on Hive-worlds.

As a weapon, the autogun is comparable in effectiveness to a lasgun but lacks some of the lasgun's versatility and reliability. Autoguns are prone to jamming, especially in dusty and muddy conditions, where intricate moving parts can quickly become fouled. A good maintenance routine is necessary for troops armed with autoguns. In general, autoguns and their ammunition are also heavier than lasguns and their power cells.

This particular autogun is an Agripinaa pattern, type III. It fires a long 8.25 calibre round, on either single shot, semi-automatic, and fully automatic, with a cyclic rate of fire of 650 rounds per minute with a muzzle velocity of 820 metres per second. It takes both a 20 and a 30 round box magazine (the 30 round magazine is shown here).



The autogun includes a flash suppressor, but one of the weapon's drawbacks is its excessive muzzle flash on firing, along with the excessive recoil of the weapon in fully automatic mode due to the size of round being fired - making fully automatic firing wildly inaccurate at standard combat ranges. The type III version attempted to correct this by the addition of a counter-weight, a heavy block placed at the front of the fore grip, designed to reduce the weapon's natural tendency to rise off target during automatic fire, thus assisting the firer in keeping the target in his sights. Whilst testing confirmed the counter-weight did aid accuracy, it also added to the weapon's considerable weight. This gun only includes a basic iron sight.

This autogun has been slightly modified by its user. The weapon's sling is a scavenged length of chain, and the weapon's stock has been replaced by a homemade wooden version, probably to fix previous damage.

### 4. CLOSE COMBAT WEAPONS

In addition to his autogun this militiaman has also armed himself with two close combat weapons. The first is a large fighting blade, worn on the back off his left arm (leaving his hand free to grip his autogun), it is a crude home-made weapon, a simple spike cut from a piece of scrap pipe and sharpened down both edges. It is attached via straps to the arm and hand, and used for brutal hacking and stabbing. Such weapons proved popular with militiamen during counter attacks, where they would be expecting to storm enemy trenches.

His second weapon is actually a handpick, a tool common amongst work gangs for breaking up rocks. The only modification is that it has been sharpened to a point for better armour penetration. In the close confines of trench fighting, hand-to-hand combat is common, and the autogun will be dropped or slung across the back to allow more freedom of movement. Although not visible here, it is likely that he also carries a fighting knife or bayonet.



*In sector 46-42, a Gorgon-borne assault advances through enemy artillery fire across no-man's land.*



Tanks of the 7th regiment supporting an attack by the 310th regiment against the second defence line.  
In the background are the peaks of the Saritama Hills.

succeed and the attackers would occupy the defenders' positions, only for the attack to then stall under the counter-barrage as the enemy's pre-sighted guns unleashed an accurate storm of fire, isolating the attackers in their new positions. As the artillery storm continued unabated, the enemy counter-attack would hit before the assaulting troops could be reinforced. In hand-to-hand fighting with grenades, bayonets and entrenching tools, the sudden riposte would drive the Krieg guardsmen back. Like the ebb and flow of the tides, the waves of Krieg infantry would crash in, only to be repulsed.

The remorseless cycle of abortive offensives went on, each time the attack would be stalled, and the next day the attack must be widened, to take in a neighbouring sector and eliminate its flanking fire. A vital sector could not be taken until its neighbouring sector was silenced. The key to each sector was always on its flanks, and so on down the line, until entire regiments found themselves ordered to attack, because a single company had failed to achieve its objective. Always the gains were negligible, and always there was a new flank that needed engaging. Over the months, hundreds of attacks were made, but there was no breakthrough. Another year passed in stalemate.

In the north, the 1st Korps, now reinforced by an influx of new troops arriving from Krieg, was pushing forwards again. Here the trenches were pushing forwards across ground littered with the rusting hulks of destroyed tanks and carriers. It was ground that had earlier been captured then lost. The enemy continued to skirmish and harass, but without the protection of their deep bunkers and the reinforced ferrocrete of the defence lines, the Krieg artillery could pulverise them. Out in the open, or sheltering in shallow trenches they suffered as never before from the Krieg regiment's bombardments. The creeping barrages would roll out, and force the enemy to withdraw or be annihilated. Slowly the ground lost to the counter attack was reclaimed, it took almost six months to recover all the ground lost in just a week. By the end of the year hab-zone one had systematically been pulverised by artillery fire, and then captured with barely a fight. After the attack, the hab-zone's prefabricated dwellings had been wiped off the map. Eventually 1st Korps was in position against the second defence line, and the Citadel was surrounded from sector 62-47 all the way anti-clockwise to sector 54-38,

a front of 250 kms.

During the 88th army's advance they had overrun many of Vraks' outer storage facilities. These huge underground bunkers, accessible via large cargo lifts down into the cavernous storehouses below, had been stripped bare. The war materials that had been stored there were gone, plundered to the last round by the rebels and moved closer to the fortress for protection. These supplies were the life blood of the defenders, the means of matching the 88th army's massive logistical support train that saw hundreds of tonnes of artillery shells being delivered every day, along with shining new barrels or breech blocks to replace those that had become worn-out by over use. But seemingly the enemy still lacked for nothing, and whilst he did, the attrition must continue.

And so it did; the tireless, pitiless cycle grinding ever on. Like an insatiable beast the siege of Vraks continued – consuming men and equipment daily, with a voracious appetite. The endless artillery duel again turned the frontline into a crater field, where shell holes, some tens of feet deep, overlapped. No-man's land again was a killing field, littered with decomposing corpses so that a grim toxic smog, a dense mixture of dust, cordite, smoke and infectious fumes soon hung in the air. Another year passed, then another, and the conditions worsened. Wherever the Krieg regiments made any gains, they were soon recaptured by enemy counter-attacks.

For the most, regiments were only required to hold the line. It was neither possible or desirable to maintain a constant offensive state along the entire front line. That is not to say that the front line was quiet or uneventful. Even when no attack was planned, both sides attempted to make their presence felt by aggressive action, which would inevitably bring a response from the enemy. Frequent sporadic fighting along the front would result in casualties. Especially night time 'bombing' raids, where a small group would infiltrate across no-man's land to throw a cluster of grenades into the enemy positions, before escaping back to their own lines. Also, small raiding parties would seek to kidnap a sentry, clubbing them unconscious before dragging them away for interrogation. Both sides employed the tactics of constant harassment, which never allowed their opponents across no-man's land a moment of unguarded rest. Such small actions were never intended to capture

ground, and small platoon or company offensives were discouraged, even as retaliation against enemy actions, because the capture of small areas of ground were insignificant in the wider scheme of the war. The result was that for long periods of time, sometimes years, the front was entirely static. What Krieg's commanders wanted was the big breakthrough, and this could only be achieved by first wearing down the enemy, then smashing through in a major offensive, supported by all the arms at their disposal.

At 649818.M41 the 158th regiment made a large raid in sector 50-45, its objective to capture and destroy a defence laser silo, part of Vraks' network of orbital defences. The silo had been buried deep, to protect it from orbital bombardment, and so any artillery bombardment that proceeded the attack had little hope of inflicting much serious damage. The defenders inside were safe so, in order to preserve an element of surprise, the attackers would go in without the usual softening-up by artillery. The attack would be led by grenadier squads, infiltrating forwards across no-man's land under cover of darkness to quickly seize the silo's surface defences, before the infantry surged through at dawn to clear the silo. The silo itself was mostly underground, protected on the surface by razorwire, a dense minefield and several reinforced gun emplacements.

On a dark and gloomy night the grenadier squads set off, stealthily slipping into no-man's land and crawling from crater to crater, slithering through the mud. Every time a starshell burst, casting its harsh light over them, everybody froze, or played dead – disguised as just another corpse. As the light faded to earth, so the grenadiers slithered onwards. Navigating in darkness was difficult, and soon several squads had become lost. One squad stumbled into a enemy patrol, itself creeping forwards to spy on the enemy or maybe toss a few grenades into a trench. A firefight erupted, but to the defenders' sentries it was just another nightly clash in no-man's land.

Those squads that reached the objective found it quiet and set about the task of cutting the first band of wire. As they crept forwards through the cleared lane a starshell sailed into the sky and exploded into a bright yellow orb directly overhead. The grenadiers all froze, only for an eagle-eyed sentry to notice unfamiliar shapes on the perimeter. The sentry was alerted, and

cried out, a lasgun shot flashed out in the darkness. Suddenly there was firing and confusion. A heavy bolter opened fire, racking those grenadiers still caught on the wire. In barracks deep below, men were being roused from sleep by bellowing officers.

The sneak attack had been spotted. The grenadiers could either fall back or press forwards, caught on the wire they would only be massacred. The leading squads scrambled through the wire and rushed forwards, conscious of the minefield they were now trampling over. Explosions lit the night, weapons fire was criss-crossing the silo, a grenadier Watchmaster was yelling for his men to follow him as he sprinted towards the closest bunker, only for his orders to be cut short as a heavy bolter shell decapitated him. Inside the wire, the air was thick with fire, grenades were exploding, wounded were crying out. One bunker was engulfed by a flame-thrower blast, turning it into a bright torch, silhouetting the darting grenadiers as they scrambled for cover. From below, the first enemy squads were arriving, running to man weapons and trenches. It was total confusion.

As dawn broke with a greenish tinged light, the silo was shrouded in smoke and dust. Watching through scanners the officers in the trenches opposite could make out very little. The mission accomplished message had not been received, but then again none of the surviving attackers had returned to report failure. The fight was still on-going. The order was given for the attack to continue as planned, and, on time, the infantry companies swarmed up and out into no-man's land. But, unknown to the new attackers, the grenadier's attack had gone badly. In the confused night-fighting the grenadiers had not cleared the surface defences, and the following infantry were once again attacking enemy heavy weapons over open ground. Soon it was business in the same old manner, withering defensive fire forcing the attackers to ground, before the defensive barrage hit, turning no-man's land into a charnel house of burned, concussed or dismembered men. Soon the survivors were straggling back into the cover of their own trenches again. In response a counter barrage of Bombard batteries targeted the silo, and continued to pulverise the defenders well into darkness, the huge explosions thundering across no-man's land. The following day, when the thick dust cloud cleared, superficial damage could be seen but the silo remained intact and functioning. It had been a

bitter exchange, but exemplary of the types of engagements being fought up and down the front on a daily basis. Several hundred had died in a hopeless attack, no doubt many more attackers than defenders had perished. Only a few of the attacking grenadiers ever reached their own lines again. Most were killed, those that were captured were tortured for information and then executed. Their bodies were left hanging on the razorwire as grisly reminders of their fate.

#### **A New Threat**

Seven years had passed since the first artillery salvo had been fired, marking the official start of the siege. Seven years of bitter and gruelling fighting that had seen millions slaughtered for the few miles gained. Each side had had its victories and its defeats, both had suffered grievous losses, but neither side was, as yet, ready to collapse.

At 820.M41 new reports reaching Lord Commander Zuehkle's HQ on Thracian Primaris made disturbing reading. Not only was his campaign plan still well behind schedule, but, if reports were to be believed, the defenders had also been reinforced. During an attack in sector 52-49 by the 261st regiment, in which several Gorgon assault transports had overrun the enemy lines and were threatening to force a gap in the second defence line, the enemy had counter-attacked, as he always did, but this time the counter-attackers had been powered armoured Space Marines. Adeptus Astartes in dark blue armour had launched a swift attack that had seen the breach quickly sealed, all the Gorgons had been destroyed in the battle.

How could it be that Space Marines were now fighting on the side of the Vraksian renegades? Whoever they were, they represented a grave development. No Adeptus Astartes forces had been committed to Vraks due to the nature of the fighting. No Chapter master would expose his battle brothers to a slow moving war of attrition. The war was locked in a stalemate, but these reinforcements could swing the balance of the war in favour of the defenders.

Lord Commander Zuehkle sent his emissaries to see the Lord-Commander Militant of Segmentum Obscurus. Could he help identify this Chapter? Along with that request Zuehkle also asked for a new line korps to join the fighting on Vraks. He believed that these extra men would bring the campaign back on schedule, and help break the stalemate at the second defence line. The order

for more men was put through the Departmento Munitorum channels, and the bureaucrats set to work on finding the extra men from Krieg. As for the mysterious Adeptus Astartes, it remained an unanswered mystery. Those Chapters in the Segmentum who wore dark blue could all account for their companies. The conclusion was that this may well be Traitor Legionnaires, drawn to Vraks by the intensity of the battle and wishing to win favour with their own gods by adding to the slaughter. Zuehkle's headquarters was assured that steps were in hand to counter the new threat.

Unknown to the commanders of 88th Siege army, Vraks had indeed become a draw to the Traitor Legions. One traitor in particular had heard news of the uprising, and the subsequent battles, and had now chosen to join the war. He was Lord Arkos, a former captain of the Alpha Legion. His battle barge *Anarchy's Heart*, had crept into the Vraks system and landed his battle brothers at the star port. Disguised as newly deployed loyalist Space Marines they had infiltrated through the Krieg lines and, under the guise of launching an attack, crossed no-man's land to reach the enemy side, before making for the Citadel. Arkos and his followers presented themselves at the Citadel, offering his support in the name of all the Chaos Gods. Arkos could not only provide the defenders with superb veteran troops, adept at raiding and disruption behind enemy lines, but also training for the militias. Arkos himself could add his own tactical experience to the defensive campaign. His brothers, all unflinchingly loyal to their commander and their gods, would relish the chance to join the war. Vraks, Arkos advised, was the anvil on which the Scarus sector could be smashed. Victory here could bring about greater victories in the future. One successful rebellion would spark another, and he already had many allies in place to kindle the flames. He also promised more allies to follow, other warbands would hear of Vraks, and they too would join the fight. Lord Arkos was a useful and powerful ally for Cardinal Xaphan, and his aid was gratefully accepted. His veteran brothers were immediately put to work.

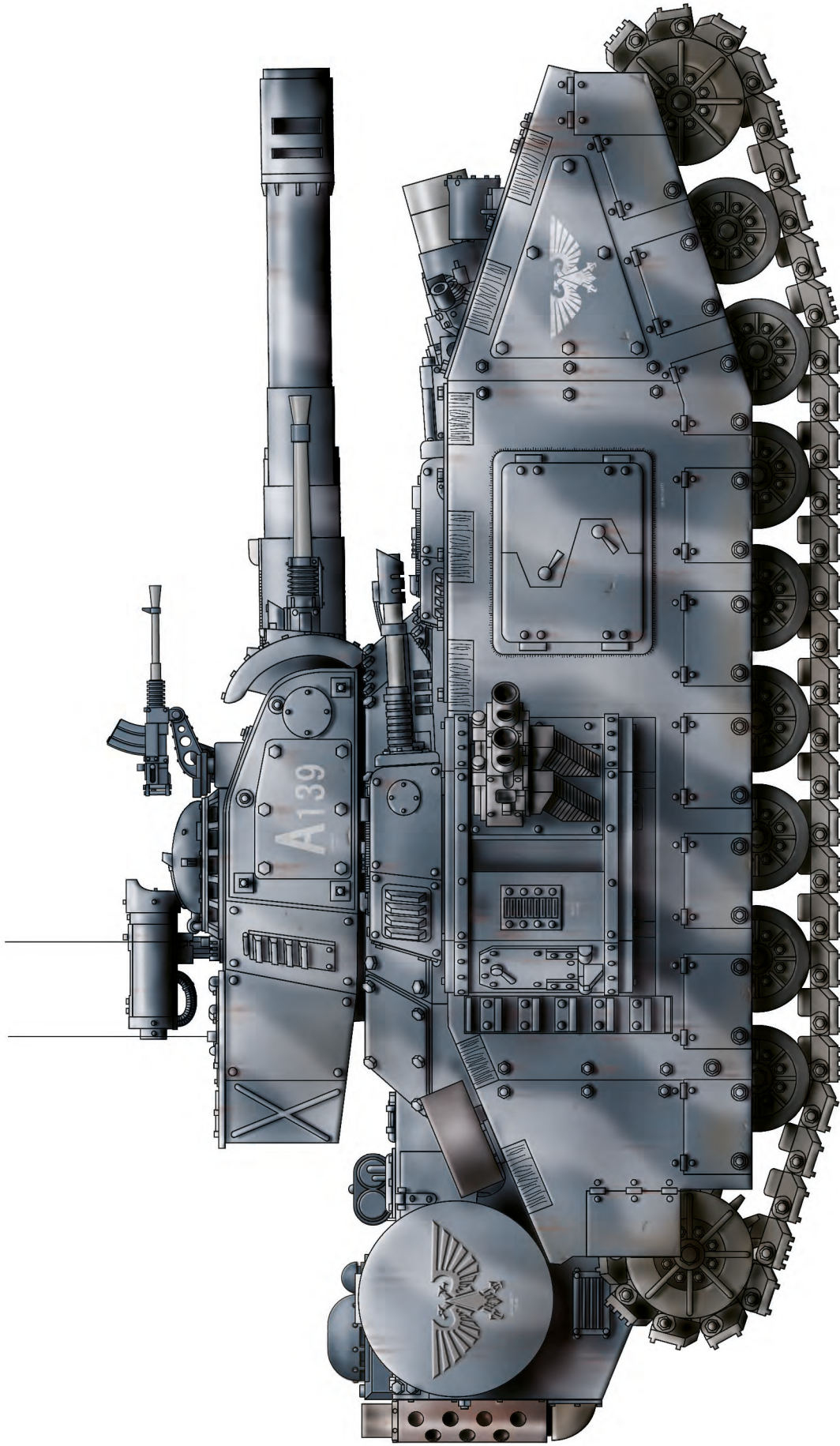

Baneblade of the 66th Tank regiment. This is the command tank of 3rd squadron, 9th Heavy company.  
Note it has additional air filters on the engine deck.



Centaur carrier of the 47th grenadier squad, attached to 13th company, 179th regiment.



Centaur carrier of the 4th grenadier squad, attached to 1st platoon, A company, 19th regiment.



Centaur carrier of the 3rd grenadier squad, attached to 10th company, 143rd regiment.

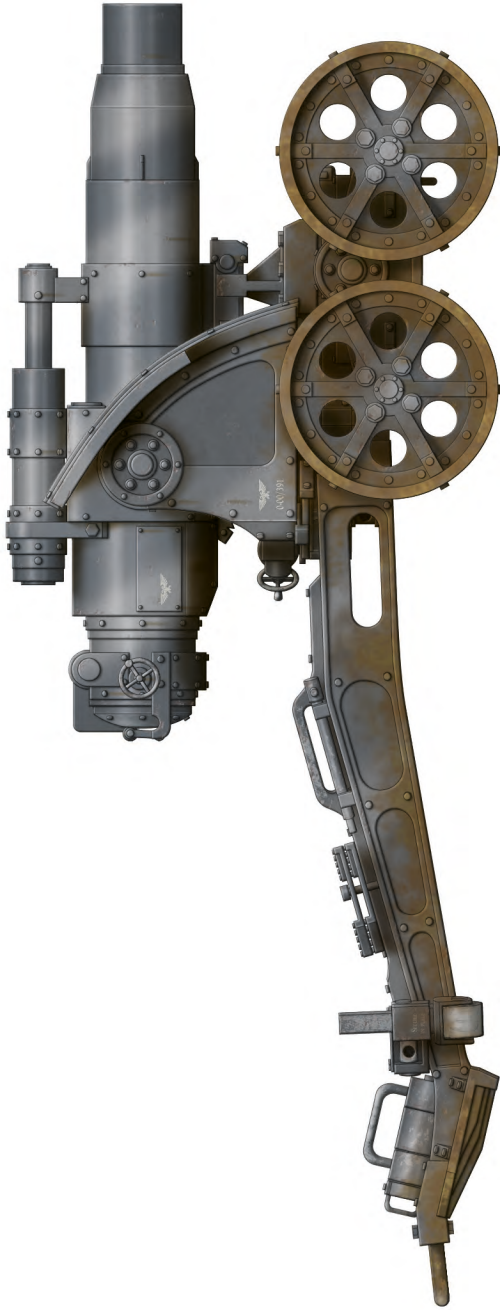

Medusa siege gun of C battery, 14th Artillery company, 143rd regiment.



Medusa siege gun of the 73rd Siege artillery company, part of the 19th bombardment corps.

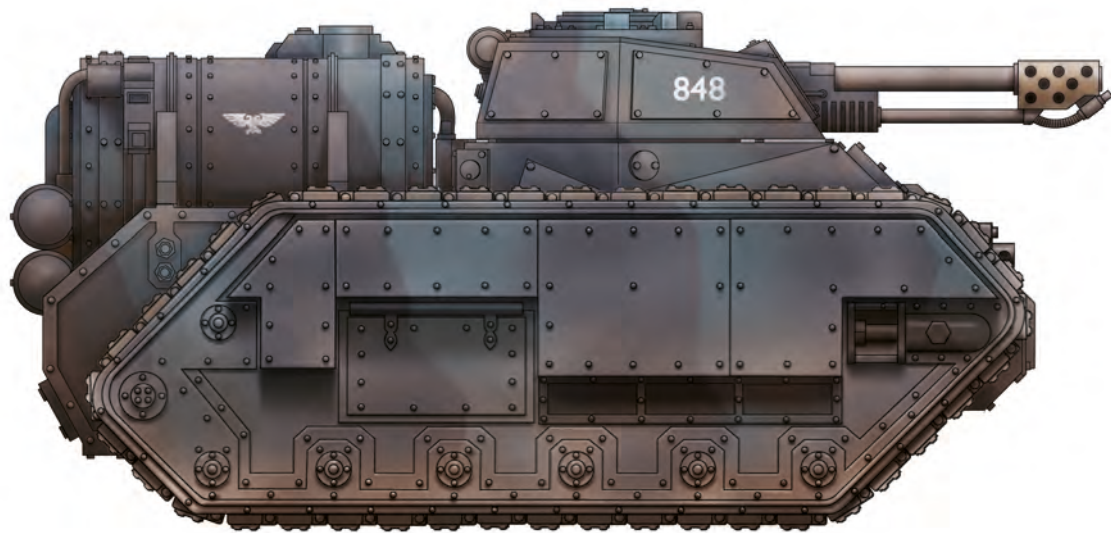

Hellhound flamethrower tank of the 179th regiment.  
This vehicle was destroyed supporting a grenadier attack in sector 59-49.

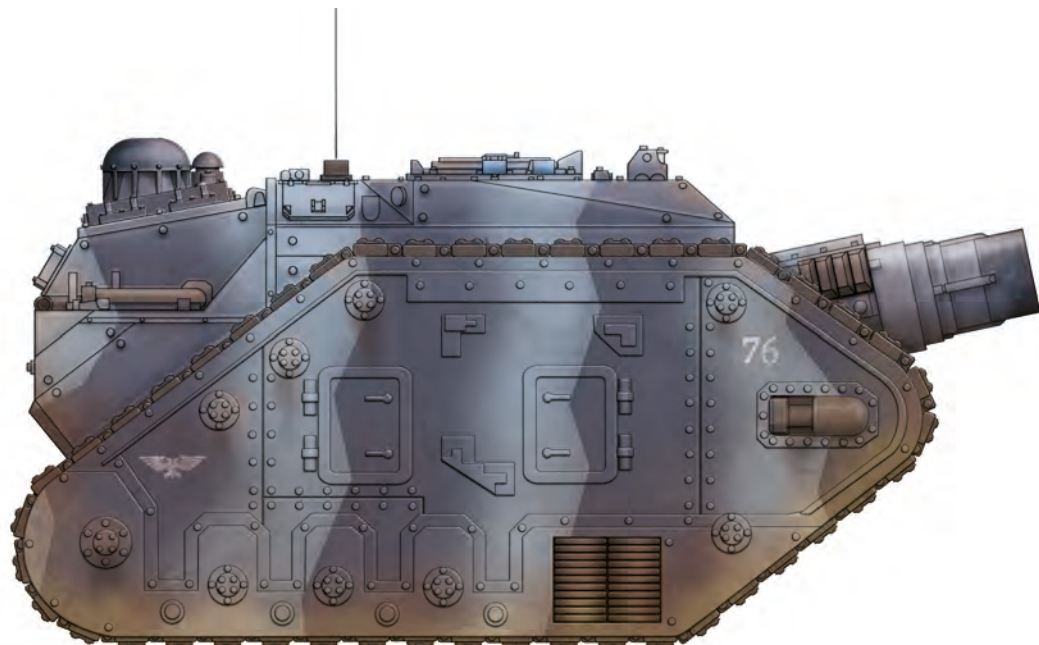

Thunderer siege tank of the 179th regiment. Note this vehicle  
has had additional filters fitted to its engine deck.

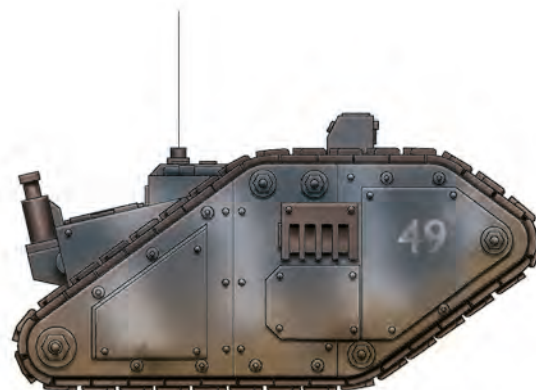

Cyclops remote control demolition vehicle. Cyclops were commonly used to attack enemy  
bunkers and pillboxes, although many were destroyed crossing no-man's land.

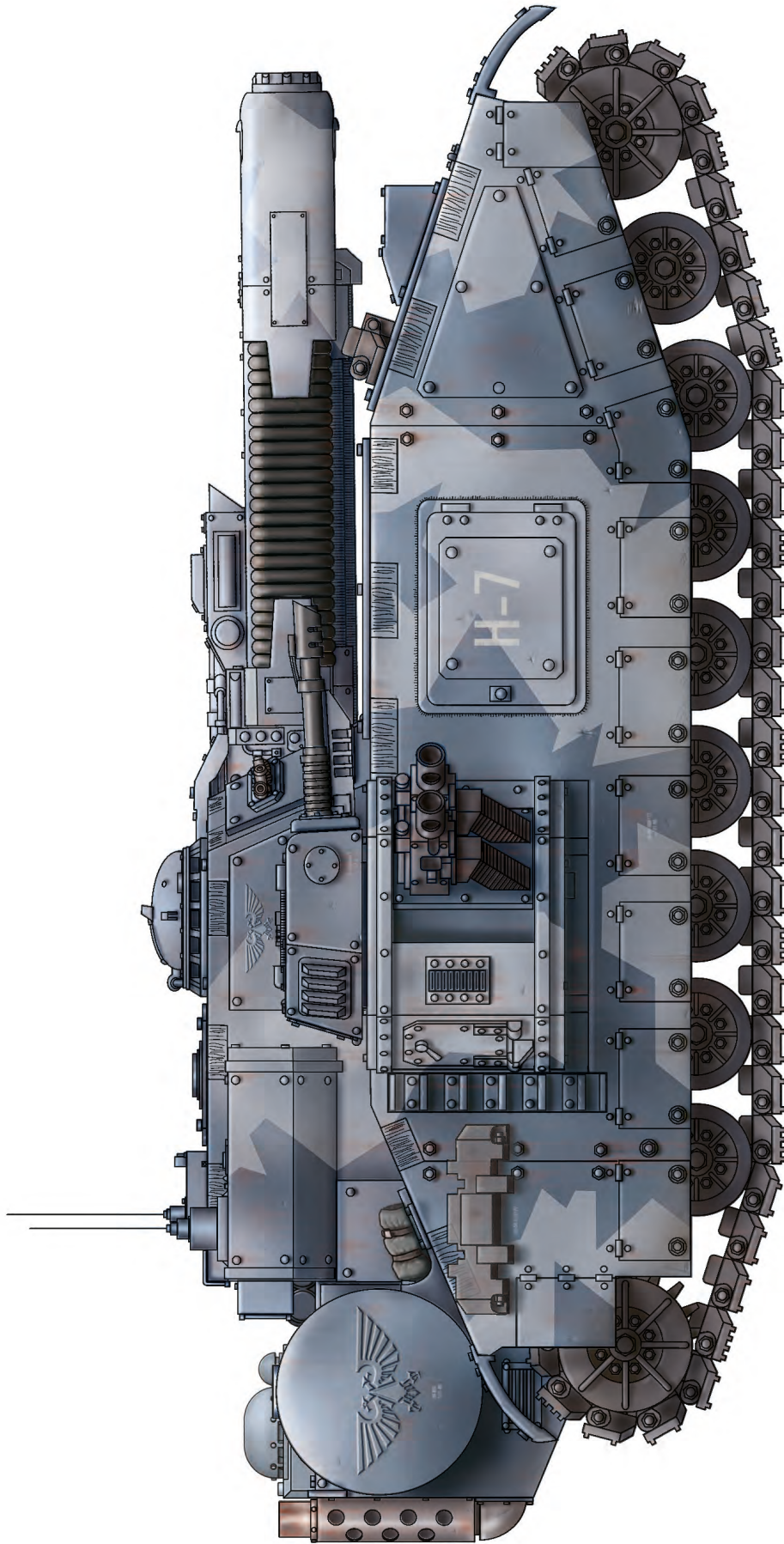

Stormblade of 61st Tank regiment. 7th company consisted of three vehicles at the start of the siege, but all were destroyed during the fighting. This is a replacement vehicle for those lost.

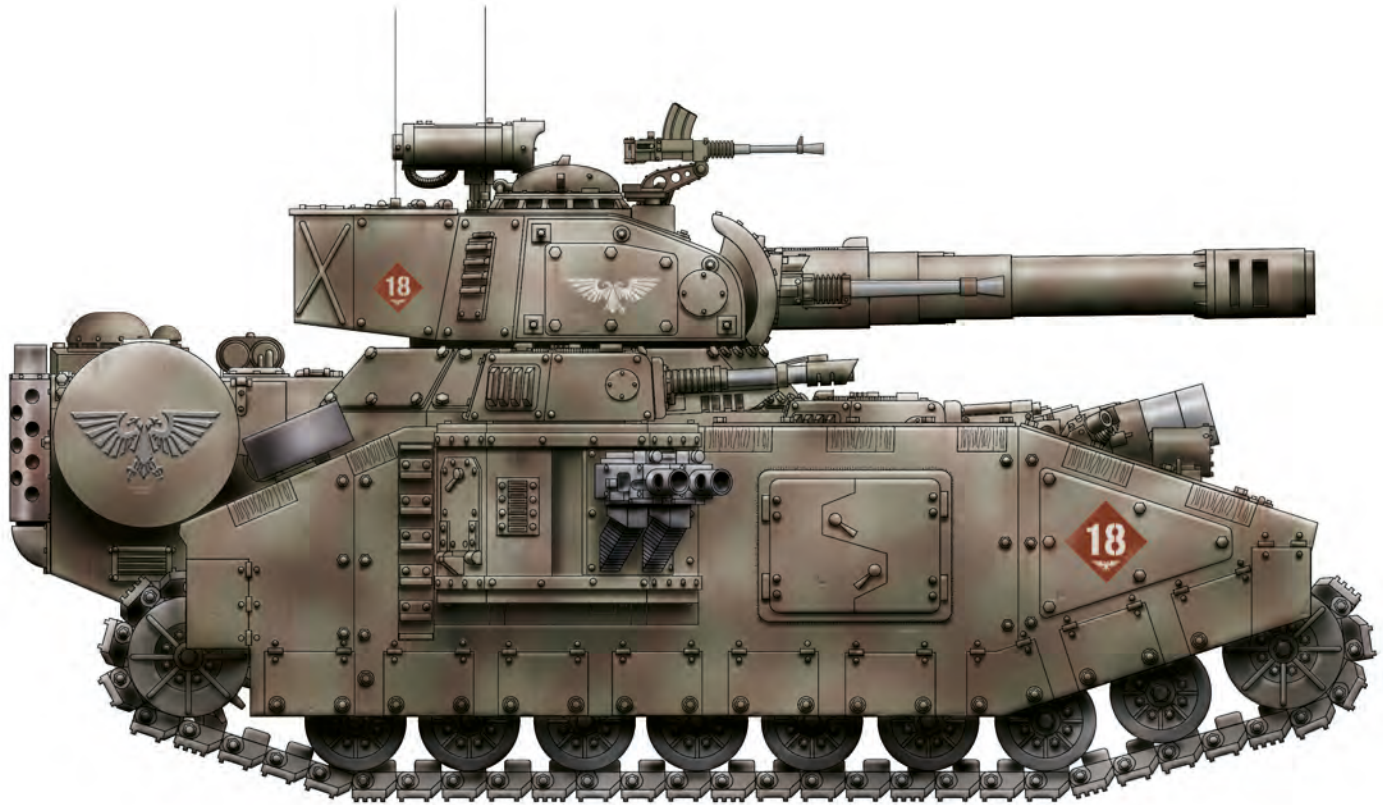

Baneblade of 11th Tank regiment, 18th Heavy company. This vehicle was destroyed by its own crew to avoid it falling into enemy hands, after being disabled by a mine in sector 53-50.

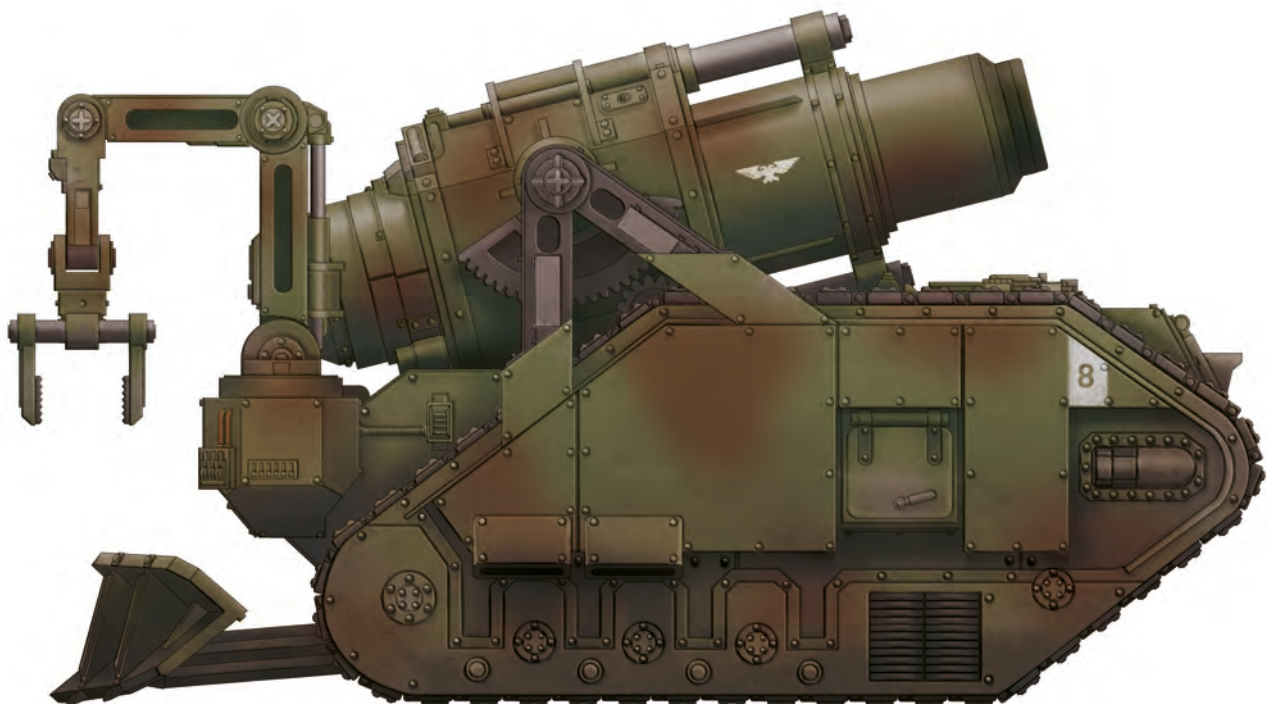

Bombard heavy siege mortar, 8th gun of the 13th Siege artillery company, 19th regiment.

# CHAPTER FIVE

## THE ANGELS OF CALIBAN

*“Our Will for Vengeance carries all before it.”*

Supreme Grand Master Azrael, Dark Angels Chapter

### Reinforcements

At 821.M41 Lord Commander Zuehkle's requests were finally met. A convoy of transport vessels entered the system carrying the 46th line korps, with three more regiments to assist in breaking the deadlock around the second defence lines. These were troops that had been designated for other warzones, but now Zuehkle's political connections had proved useful in getting the extra troops he wanted.

The Lord Commander Militant's office had also provided some unasked for assistance. The arrival of off-planet reinforcements for the defenders was a worrying development, and potentially a disastrous one if other forces followed these traitor's and also came seeking battle, plunder and glory for their gods. The chance that the war on Vraks would escalate could not be taken. Instead, the Lord Commander Militant had acted independently of his subordinate commander and sent his own delegation in search of aid from the Adeptus Astartes. The first to answer were the Dark Angels, the infamous first chapter of the First Founding, whose base in the Caliban system had allowed them to react quickly. Led by Supreme Grand Master Azrael, the Chapter had responded with a huge commitment of forces – almost half of the Chapter's battle brothers had been embarked for Vraks, with Azrael himself taking command. The battle barge *Angel of Retribution* powered into the Vraks system along with the strike cruisers *Sword of Caliban* and *Salvation* and a small fleet of escorts.

Azrael sent no communications to the 88th Siege army's commanders. He simply set about his self-assigned mission – the destruction of Vraks' star port, and therefore the severing of Vraks' easy access to off-planet reinforcements. He needed no assistance, and saw no reason to involve the Imperial Guard regiments engaged on Vraks.

Whilst Lord Zuehkle staff were adjusting their plans for the inclusion of his new line korps into his front, Azrael and his Company Masters were manoeuvring into low orbit and deploying their

powerful strike force onto the surface of Vraks via drop pods and Thunderhawks.

### Azrael's Plan

The place Azrael had chosen for his landing was the Srna Flats, at the foot of the Abaros Hills, directly south of the star port. His fleet achieved orbit outside of the defence laser coverage, before releasing their cargos of Thunderhawks to enter the atmosphere and fly around the planet to the chosen landing zone. Where an Imperial Guard regiment can take days to unload from orbit, it took the Dark Angels just a few hours. The launch decks echoed to the blast of Thunderhawk engines as the Space Marine Companies and their supporting equipment blasted off, one after another. The Thunderhawk transporters were already ferrying to and fro, laden with vehicles and stores.

Azrael had chosen his target for several reasons. The first was obvious. The star port was the easiest way for off-planet support to reach the defenders. Secondly, a new attack would force the defenders to commit forces against a new threat. Currently only a small garrison was needed to defend the star port, because it was not directly threatened by the Krieg regiments, and this in turn freed troops for the front line. The Dark Angels could draw enemy troops into a new battle, and thus thin the lines, which would aid the 88th Siege army's attacks and help bring about the long awaited breakthrough. Thirdly, and this was a secret known only to the Dark Angels themselves, and was probably the most compelling reason for their quick response. There were Traitor Legionnaires now on Vraks. Those traitors might have knowledge about the location of 'the Fallen'. Azrael had no hard proof that any Fallen were amongst the defender's new allies, but the inner circle of the Dark Angels knew the name Arkos well. He was a reviled black traitor from the old days of the Horus Heresy. If Lord Commander Zuehkle could not identify the powered armoured forces now facing him, the Dark Angels' inner circle knew full well who these men were. Azrael brought along Interrogator-Chaplain Belphegor to extract information from any traitors he could capture.

Once he had chosen to commit his Chapter to Vraks, Azrael's plan of attack had to be carefully considered. He was not going to enter into the war of attrition, instead he would launch a fast moving armoured column across the Srna Flats, envelope the star port, and then strike wherever he felt the enemy was weakest. Timing for the attack was vital, he needed to wait long enough to allow enemy reinforcements to arrive, but not so long that there became so many enemy forces that his mission would be jeopardised. Azrael would be committing his battle brothers to intense street fighting without the aid of his largest guns – the orbital bombardment of his battle barge and strike cruisers. His ships would not risk Vraks' defence lasers. He was taking calculated risks.

Once the attack on the star port was underway, he would attempt to seal off the battle area from further reinforcements by capturing and destroying the main roads across the Srna Fault line and Balan trench. These were a set of grand causeways that carried the service roads over the huge chasms. With these gone no reinforcements could move from the Citadel or the defence lines to assist in the battle at the star port. This task was given to 3rd Company under Master Orias. The third battle company would attack each causeway in turn, landing via Thunderhawk gunships, overwhelming any resistance to set demolition charges to destroy the causeway, then move on to next target. Once complete they could move to aid the rest of the strike force already engaged at the star port.

For the defenders, the arrival of the highly mobile Adeptus Astartes strike force created a strategic problem. The Space Marines could strike anywhere, anytime. They could simply over-fly the defence lines to strike directly at the citadel itself. Now Arkos' wisdom proved invaluable and correct. The Dark Angels would not risk attacking the fortress with its defences and garrison still fully intact. No, they would seek to influence the campaign in other ways. Still, the Cardinal needed to be able to counter the Space Marine attack wherever it fell, so troops had to be withdrawn from the second defence line and sent

to garrison other locations, including the star port. The presence of just five hundred Space Marines was already influencing the entire war on Vraks.

### The Battle of Vraks Star port

At 944821M.41 the Dark Angels began their attack. First they faced a 200 kilometre advance overland across the Srna Flats. The armoured columns of Land Raiders, Predators, Rhinos, Vindicators and Whirlwinds were preceded by the Ravenwing's Land Speeders, skimming ahead, flying close to the ground to search for any enemy blocking the chosen route of advance. These Land Speeder squadrons were in constant communication with the fleet of Thunderhawk gunships, which would now act as aerial cover to the advancing tanks, and provide a long range, first-strike capability should the enemy move against the columns.

The only troops not embarked for the spaceport were Orias' 3rd Company. They maintained a defence around the base until required to launch their own part of the operation.

Whilst the Dark Angels armoured columns raced across the flatlands, the enemy responded with its own reconnaissance forces. Sentinels and

Salamanders criss-crossed the Srna Flats trying to locate the enemy. Occasionally a Sentinel would burst apart in a shower of flames and sparks as a black Land Speeder swooped in, assault cannons blazing. The enemy commanders soon knew that the Dark Angels were heading northwards across the 200 kilometres, their target must be the star port. Immediately reinforcements were ordered to strengthen the garrison. Moving fast, the Dark Angels' vanguard, led by Supreme Grand Master Azrael riding in his personal Land Raider *Prometheus Angelis Imperator*, were in sight of the star port.

### Battle at the Causeways

Meanwhile, as Azrael's attack was commencing, Master Orias' Thunderhawk-borne force was closing in on the Balan trench causeway. The first of three Thunderhawks in the flight banked away, over-flying the eastern end of the mile long causeway to deploy its assault squads. Leaping from the speeding gunship, the two assault squads made a low level jump directly onto the eastern end. The defenders were quickly overwhelmed, most fled rather than face the Dark Angels. Those that stayed were quickly cut down. The

causeway was not strongly held, only a small garrison had been detailed to guard it and man a checkpoint, and they were easily outmatched by the approaching Dark Angels. The second and third Thunderhawks opened fire with missiles and turbo-lasers, blasting great hunks of masonry from the ancient monumental causeway and turning the checkpoint bunkers into smoking rubble. On touch down, the Dark Angels' tactical squads deployed from the ramps and were soon rushing along the roadway, boltguns hammering as the defenders fell back pell-mell before the attack, only to find themselves quickly cut-off by the assault squads which had already captured the eastern end. Caught with nowhere to run, the garrison was wiped out.

Orias' lightning airborne assault had captured the target in just a few minutes. He set to work rigging the demolition charges, whilst his devastator squad dug in on the eastern end to cover any enemy approach from the west. Soon, enemy vehicles were seen approaching along the road, heading towards them in an attempt to reinforce the star port. The leading tank erupted into flames as a well-aimed lascannon shot tore through its front armour. The crew stumbled out on fire, each man a human torch. The following Chimeras swerved to avoid the blazing wreck now blocking the road, only to find themselves under a withering fire from Orias' heavy weapons. Krak missiles and lascannon blasts turned each vehicle in the column into a smouldering wreck. In just a few minutes the area was littered with the burning hulks of Leman Russes, Chimeras, Sentinels and Basilisks.

As the devastator squads defended the bridge, the assault squads completed the demolition work. The explosive charges were in place on each of the causeway's main supports. Orias ordered all his men back across the causeway for immediate evacuation. The Thunderhawks swooped in again and all Orias' brothers climbed aboard. His first attack had cost him just three injured men, all of which, due to their enhanced physique, were fit to continue. As the last Thunderhawk lifted off and banked away north, Orias triggered the detonator. Each of the causeway's supports had been primed, and one after another the explosions knocked out those supports. The ancient edifice of the causeway groaned, cracked, then crumbled under its own weight - the rubble plunging into the deep abyss of the Balan trench, leaving only an expanding cloud of masonry dust. The

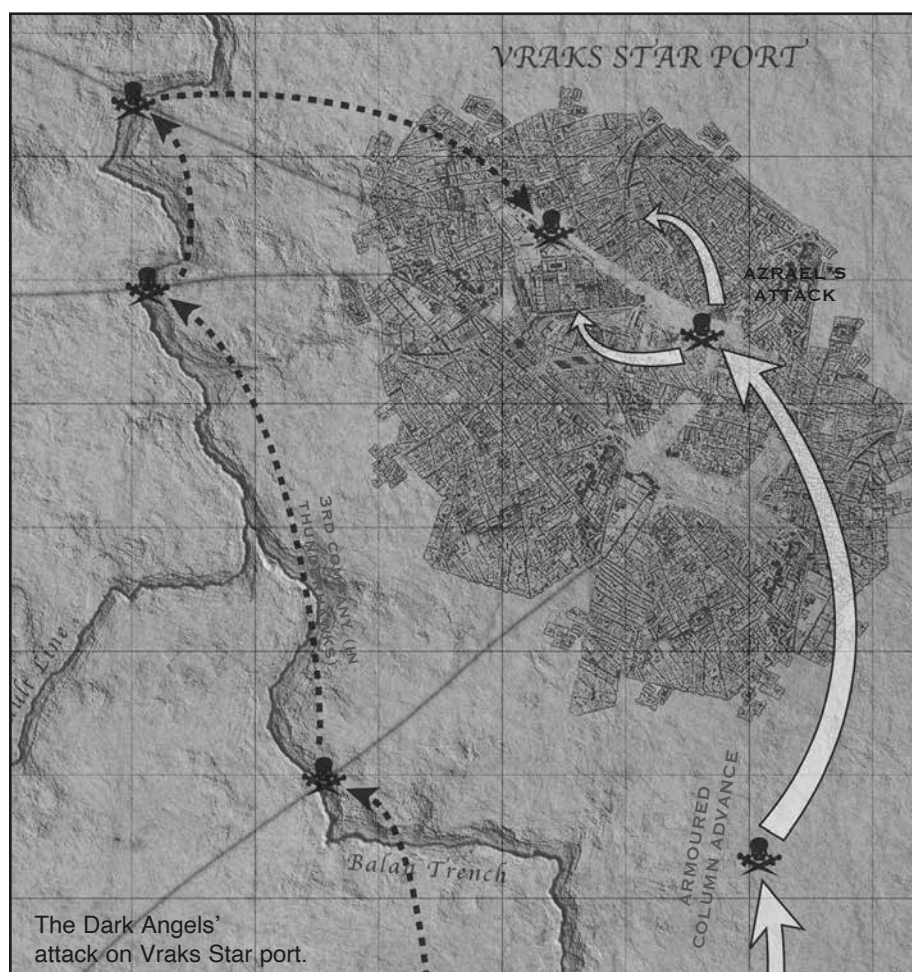



main reinforcement route had been severed. By the end of the day, both the causeways across the Srna trench would also be captured and destroyed by Orias' force.

#### **By the Emperor's Wrath**

As Azrael stood in his Land Raider's cupola, looking across the flats towards the spires and roof tops of the star port, which stretched away to the horizon, his communicator descrambled a message. Ravenwing outriders reported an enemy tank column in sector 74-46 moving southwards from the star port. The enemy were coming. Azrael directed his covering Thunderhawks to intercept, and ordered his own column forwards to engage. From his command Land Raider he monitored the Thunderhawks as they raced low to strafe the column. Hydra fire was snaking up to meet the Thunderhawks, but the gunships' payloads of missiles, along with lascannons and turbo-lasers were inflicting heavy losses on the enemy vehicles in the open. With no airforce to protect them, the enemy were at the Thunderhawks' mercy. By the time the leading Land Raiders were directed to the battle by the Land Speeder scouts, the flats were already shrouded in the drifting smoke of burning wrecks. The Land Raider's heavily armoured bulk smashed into the remaining enemy tanks, lascannons cutting through the Lemman Russes and Chimeras as the enemy sought to withdraw to the relative

safety of the star port. Azrael's thrust cut clean through them, and swept eastwards, circling the star port. The Supreme Grand Master had already received Brother Orias' confirmation of the destruction of the first causeway. Now he planned to attack from the east of the star port, draw the bulk of the enemy garrison to him, then move in 3rd Company from the west, catching the garrison between Orias' anvil and his own hammer.

The first probes into the streets of the star port were by skimming Ravenwing Land Speeders, who reported back the best routes of advance into the city limits. Now Azrael sent forward his Vindicators, supported by battle brothers riding in Rhinos and Razorbacks. The Vindicators smashed the buildings occupied by the enemy infantry before his battle brothers disembarked and began clearing the ruins of any survivors. With the ruthless efficiency of the Space Marines, it was all going to plan.

Azrael's strike force moved through the streets of the star port and unleashed unrestrained destruction upon it. Overhead Thunderhawk gunships had already re-armed, and were now remorselessly bombing the enemy from above. Whirlwinds were firing salvo after salvo into the star port, their fire directed by the Ravenwing as they identified enemy concentrations before speeding away to safety. The enemy

found themselves under constant attack as Azrael's armoured thrusts carefully advanced, clearing the way as they went. As night fell there was no let up in the attack. Azrael continued to push forwards in darkness. By dawn's first light the Dark Angels had cleared the eastern approaches to the star port's northern landing fields, and the enemy had fallen back in disarray. Before dawn the 3rd Battle Company were also in position, landing to the west of the main landing fields and deploying as the back stop against enemy withdrawals.

By first light the enemy were occupying the large buildings surrounding the landing fields, hangars, warehouses and maintenance sheds were being turned into strongpoints as the Whirlwind's barrage continued to fall about them. The enemy fortified their positions as best they could, utilising anything large and solid that came to hand to create barricades, including the landing field's service vehicles, many of which were overturned to block the approach roads. The roar of approaching Thunderhawk engines could be heard again as the gunships arrived to deliver their bomb payloads onto the defenders. For the second day of his attack, Azrael contented himself with softening up the enemy and sending out fighting patrols to probe enemy positions. He was giving the enemy time to bring more defenders into the defensive ring. His aim was not simply the quick destruction of the landing fields, but also the annihilation of the forces defending the star port. The second day passed with sporadic fighting, but the star port continued to echo to the sound of Whirlwind missile impacts and the crash of the enemy artillery as it sort to return fire, although the Whirlwinds' mobility made counter-battery fire very difficult, because the lighter artillery was changing position after each salvo.

By dawn on the third day, the landing fields were starting to look like a war zone. Rubble and masonry lay scattered in piles around the streets from the repeated air raids and missile strikes. From yesterday's patrols Azrael now had a good idea of where he would attack in force. He mustered the battle brothers of 6th Company, mostly tactical squads, placed them under the direct command of Interrogator-Chaplain Belphegor and gave them the honour of being accompanied by the Chapter's Sacred Standard of Devastation into battle, hand picking veteran brother Anmael as its bearer. Given extra zeal by these two honours, the 6th Company was to hook southwards and launch

an attack to seal the defenders in from the south. Accompanied by Vindicators, Whirlwinds and Predator tanks, the company jumped off its attack and was soon enmeshed in house-to-house fighting with the defenders. The Space Marines excelled in such bitter hand-to-hand combat, and as the close range fire of Vindicators tore buildings down in a single blast, the streets became choked with dust and rubble. The dark green armoured figures of the tactical squads could be seen advancing through the ruins, the bright orange tongues of flamer blasts burning the defenders out of their cover. After a day of heavy fighting, the streets were littered with the dead. Belphegor reported that the souls of fifteen battle brothers had joined their Emperor, but that the southern sectors had now been cleared of resistance.

Day four of the battle began with Azrael again content to improve his position and bomb the enemy into submission. Dark Angels patrols continued to crunch through the rubble and shattered glass, but there would be no major attack today. Azrael knew that the renegade forces now occupying the star port were cut-off from re-supply and reinforcements. Time was on his side. Thunderhawk Transporters arrived to deliver supply pods full of fresh ammunition and fuel for his vehicles. His men had been fighting for three days without ceasing, but their power armour was sustaining them and would continue to for a long time yet. After consolidating his position, Azrael called his company masters together for a briefing. Gathered inside *Angelis Imperator* the veteran commanders discussed the best plan to destroy the pockets of enemy forces they had created. A plan of concentric attacks was decided upon. First an attack from the east by Azrael's forces, then from the south by Belphegor's Company, then from the west by Orias' men. Three days would see the enemy perimeter squeezed hard into a smaller and smaller pocket. Then Azrael himself would lead the final assault to destroy the resistance, along with the Deathwing Terminator squads he, as yet, had not committed to battle.

So it was ordered, and so it was carried out. Over three days each force took its turn in squeezing the enemy tighter. Each day saw the attacking Space Marines, reinforced with vehicles and Dreadnoughts, involved in the hard fighting to systematically clear buildings, and, with Thunderhawks still roaming the skies unopposed, the enemy had little chance. Every local counter-attack the enemy tried was repulsed. During

Orias' attack 3rd Company reported they had overrun several landing pads and identified and engaged a force of Traitor Legionnaires – treacherous followers of Arkos. The Alpha Legion had committed forces to the defence of Vraks' star port. Azrael wanted as many of the Traitor Legionnaires captured as possible. Come the final battle, their capture would be one of the objectives of the Deathwing's assault.

The Dark Angels had been fighting for Vraks star port of eight days before Azrael ordered the final assault. He mounted up in his Land Raider again, and leading elements of the 1st, 2nd, 5th, 8th and 9th Companies the Supreme Grand Master moved out to finish the enemy's resistance and finally overrun the star port. As missiles and shells exploded about them, the Dark Angels attacked in force. There was no quarter to be given here, those that had turned from the Emperor's light must die. With their righteous fury still burning strong after ten thousand years, the Dark Angels sought vengeance for the ancient treachery that had so nearly destroyed their Chapter and the Imperium of Man.

The fighting was fierce and bloody, but the renegades could not hope to stand against the massive armoured might of the Deathwing. Five Terminator squads went from building to building, storm

bolters, heavy flamers and assault cannons blazing as they swept all before them. At the height of the battle Azrael's Land Raider was hit by a lascannon blast that tore off a weapons sponson. The resulting detonation of heavy bolter ammunition disabled the tracks and immobilised *Angelis Imperator*. Within, Azrael donned the Lion Helm and, with his silent cloaked companion and his command squad close behind, lowered the front ramp and charged out into the fire swept street. Bellowing "Vengeance! Vengeance! Vengeance!", he plunged into the enemy ranks, the black blade of the Sword of Secrets cutting a bloody swathe as the Lion Helm protected him from harm. His usually white over-ropes turned red with the blood of his foes as Azrael's furious assault saw many enemy fleeing before him. Other assault battle brothers arrived to aid their commander, and it seemed the day was won – until the Alpha Legion counter-attacked. It seemed the crafty veterans had been lying in wait, using the militiamen as bait to draw the Dark Angels on. Now they sprung their trap, appearing from their hiding places to bring Azrael's brothers under a storm of bolter fire. As bolter rounds exploded all around, Azrael saw brother Anmael fall, riddled with fire, and the Sacred Standard he was brandishing toppled. Azrael knew he must recover the banner, it could not be allowed to lie in the dust. Racing through enemy fire he reached the banner just as the enemy did. The Dark



Opposite Top: Dreadnought armoured battle-brothers of 5th Company during the battle.  
Above: Dark Angels armoured vehicles advance on Vraks star port.



*Left: The Dark Angels' command post in the outskirts of Vraks star port. Note the strike force's Damocles Rhino in the background. Whilst not a combat vehicle, the Damocles played an important role in co-ordinating the actions of the many sub-units operating on Vraks, freeing Azrael to lead from the front.*

Angels and Alpha Legionnaires fought over the fallen body of brother Anmael, neither giving any ground. Whilst the other Dark Angels fought to escape the Alpha Legion's sudden ambush, Azrael cut down the last of his enemies and plucked up the banner. As he did so, a massive armoured figure strode through the smoke, his ancient power armour decorated with blasphemous runes and the heretical eight-pointed star of Chaos Undivided. Arkos himself charged Azrael. As he did so an Assault Marine launched himself into Arkos' path, only to be cut clean in two by the stroke of the Chaos champion's warp-powered blade. The two mighty heroes clashed. In one hand Azrael held the Sacred Standard of Devastation, in the other the Sword of Secrets. The two rained smashing blows upon each others armour, until blood seeped through the joints of Azrael's suit of artificer armour. The weight of Arkos' mighty blows had wounded the Supreme Grand Master. Both summoned up every ounce of strength, but Arkos had the combined power of the four Chaos gods with him this day. Chanting a litany to his gods, Arkos' blows forced Azrael ever backwards, weakening his opponent until a shoulder charge and a fast, low sweeping cut sent Azrael sprawling to the ground, the Sword of Secrets skittering from his grasp. Prone amongst the rubble, the banner still clutched to him, Azrael saw death approaching. Arkos loomed over him. The Chaos champion laughed in triumph and raised his Darkblade for the killing blow.

And as he reached out to strike the blow that would see the Supreme Grand Master's reign ended, the impacts of an

assault cannon sent Arkos staggering backwards. Racing up the street came Deathwing Terminators led by Interrogator-Chaplain Belphegor, enclosed in his black Terminator armour, Crozius Arcanum held high as he charged into Arkos. Catching him off balance, Belphegor smashed the traitor to the ground with a blow that cracked his armour. Now Arkos fell dazed and bleeding. Concerned for his wounded commander, the Chaplain turned to aid Azrael, who was still sprawled upon the floor, barely conscious. When Belphegor turned back Arkos was gone, vanished into the encircling dust like smoke on the breeze.

Azrael had been badly wounded in his duel, but the Apothecaries soon had him on his feet again, and evacuated him via Thunderhawk gunship to the battle barge to recover. Command on the ground passed to Master Orias. Meanwhile the enemy was making his last stand. The Alpha Legion soon drifted away, recalled by their thwarted commander. Their ambush had inflicted painful losses on the Dark Angels, but the traitors could not win this battle alone. The surviving militiamen sought to escape the star port, and two more days of fighting would see their scattered remnants hunted down and destroyed. After ten days the star port was securely in the Dark Angels' hands. They set about destroying the facility with demolition charges. After two more days the star port was damaged beyond repair, the landing fields were booby trapped with mines before the Dark Angels withdrew back to their waiting battle barge and strike cruisers

The ten day battle for the star port was a victory, but the Dark Angels had paid a high price in blood. Their Supreme Grand Master was recovering from wounds and Sacred Standard Bearer Anmael had been killed, as had almost two hundred more battle brothers, all of who would need replacing back on Caliban. They had failed to take a single Traitor Legionnaire alive, although the battle barge's cells did contain many captured renegade militiamen who would face the Interrogator-Chaplains on return to Caliban. Azrael forwarded a characteristically laconic astropathic message to the 88th Army headquarters on Thracian Primaris. It simply read, "By the Emperor's Wrath, Vraks star port destroyed. Mission complete." With that, his strike force was gone.



*Top: Spearhead of the attack. A Land Raider leads the advance against Vraks star port.*

*Above: Vraksian renegades investigate the wreck of a Land Speeder Tempest after it was forced into a crash landing in the vicinity of Vraks star port. This squad have brought along an Ogryn Berserker.*

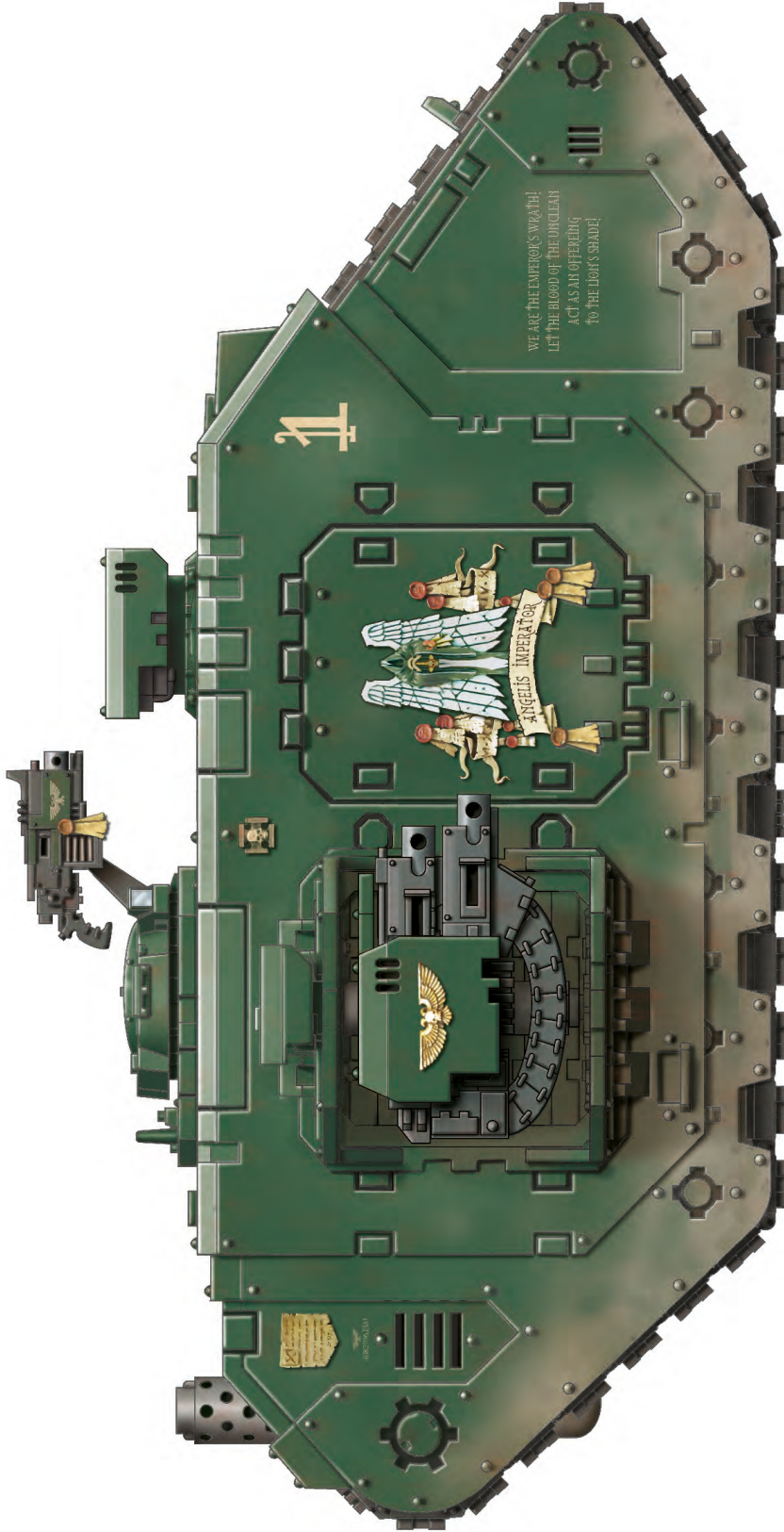

Land Raider Prometheus 'Angelis Imperator'. This is the personal transport and command vehicle of Supreme Grand Master Azrael during the Vraks campaign. It was seriously damaged during the battle, but was later recovered for repairs.

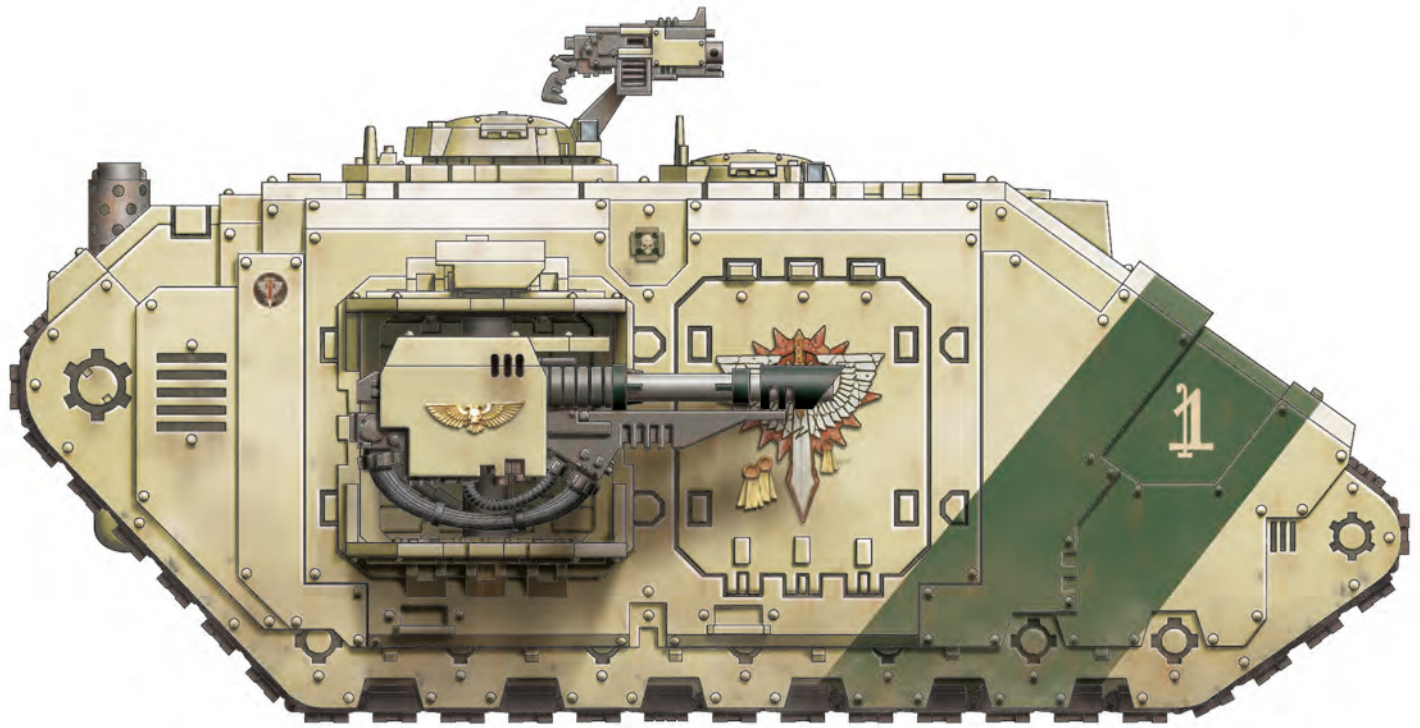

Land Raider of the Dark Angels 1st Company, Deathwing. This vehicle transported a Terminator squad during the the final phase of the battle for Vraks' star port.

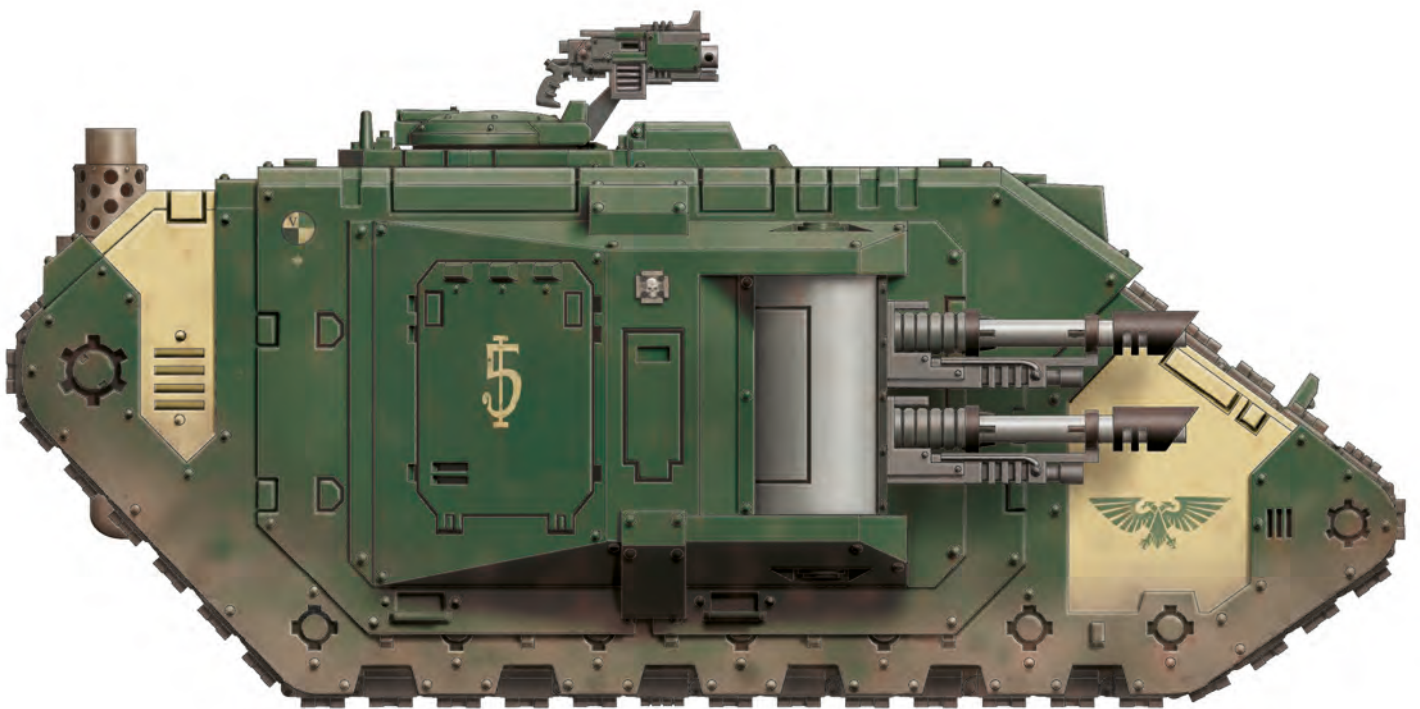

Mk IIb Land Raider attached to the Dark Angels' 5th Company for the duration of the Vraks campaign.

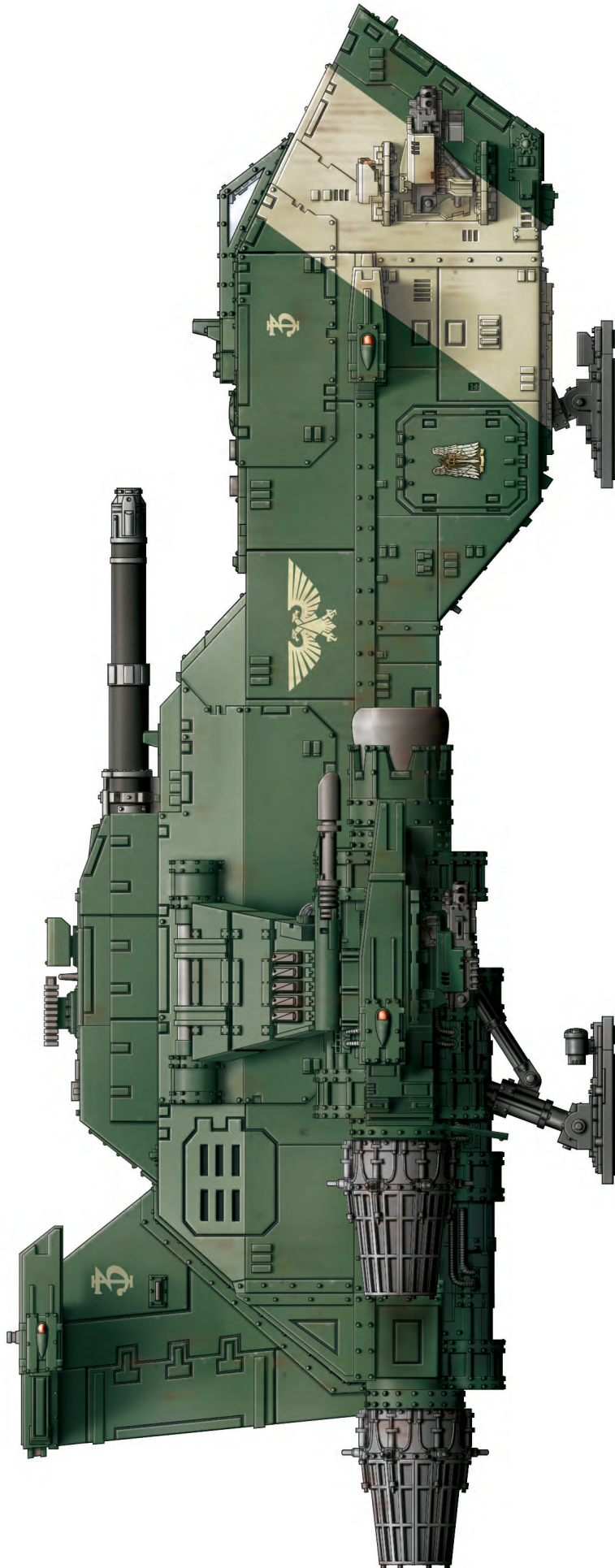

Thunderhawk Gunship attached to 3rd Company. This aircraft transported 3rd Company squads for their attacks upon the causeway bridges.

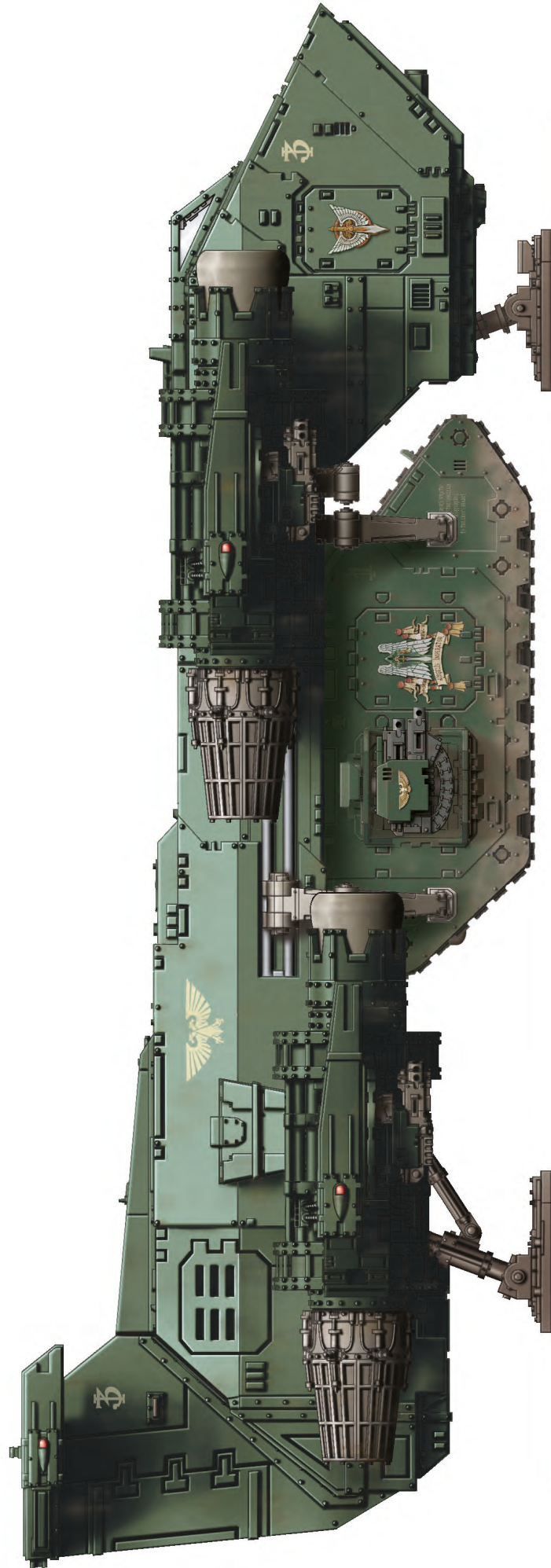

Thunderhawk Transporter number 3. These support aircraft played a vital part in supplying the Dark Angels throughout the campaign.

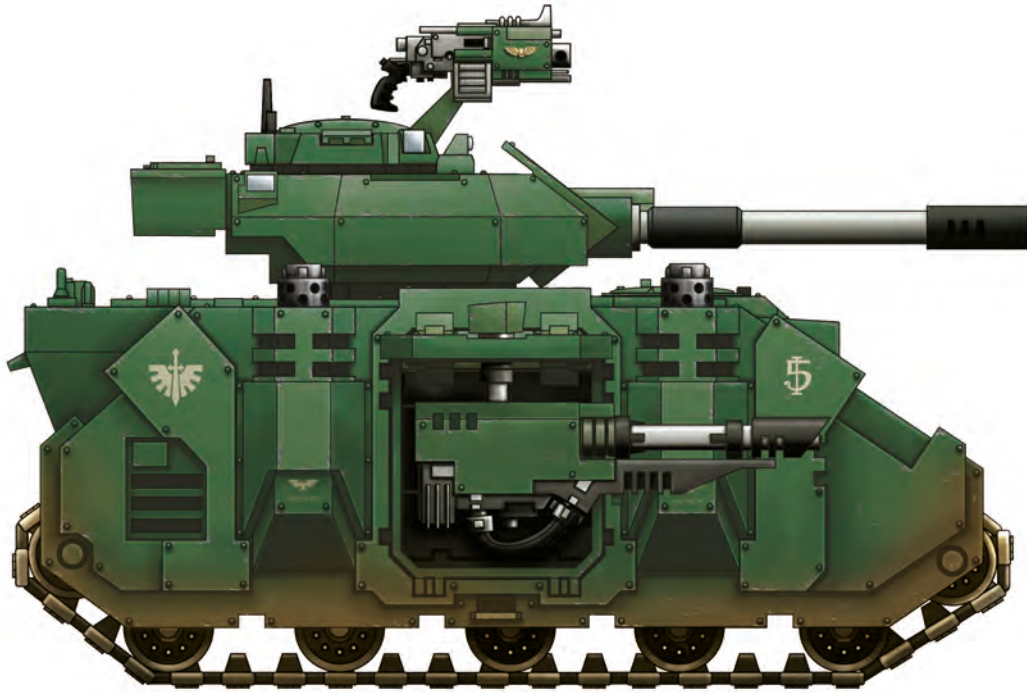

Predator Destructor with extra armour plates, attached to 5th Company.

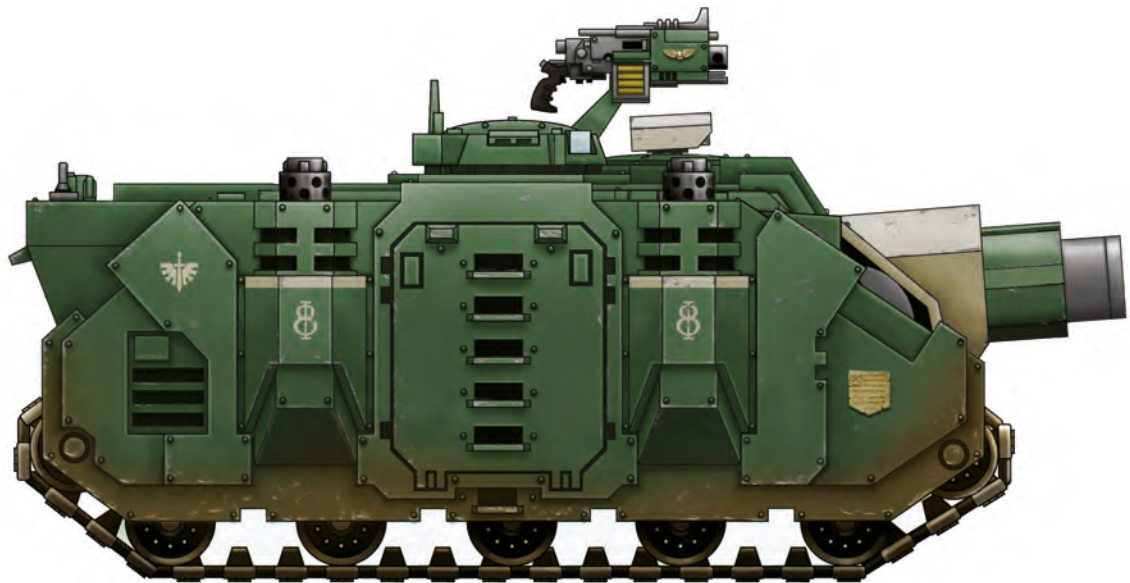

Vindicator with extra armour plates. This is the strike force's 8th vehicle.

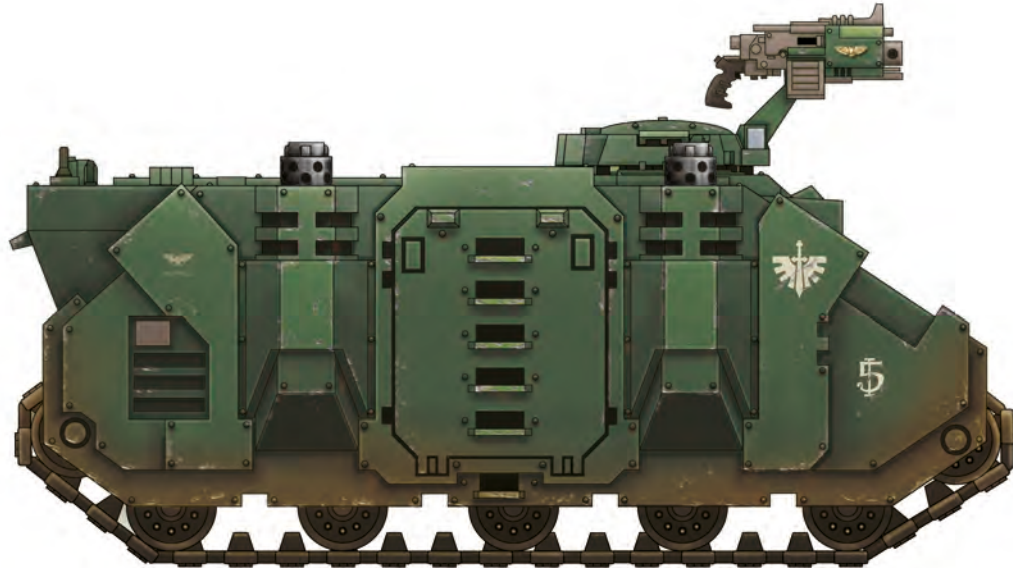

Rhino with extra armour plates of 5th Company.



Mk IV Dreadnought, Brother 'Yaziel', of 5th Company, armed with twin-linked heavy bolters.

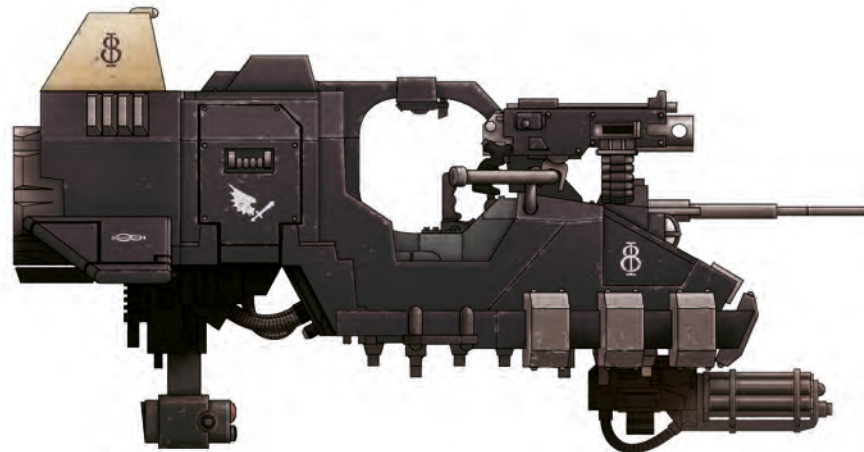

Land Speeder Tornado of 2nd Company, the Ravenwing. This is the company's 8th vehicle.

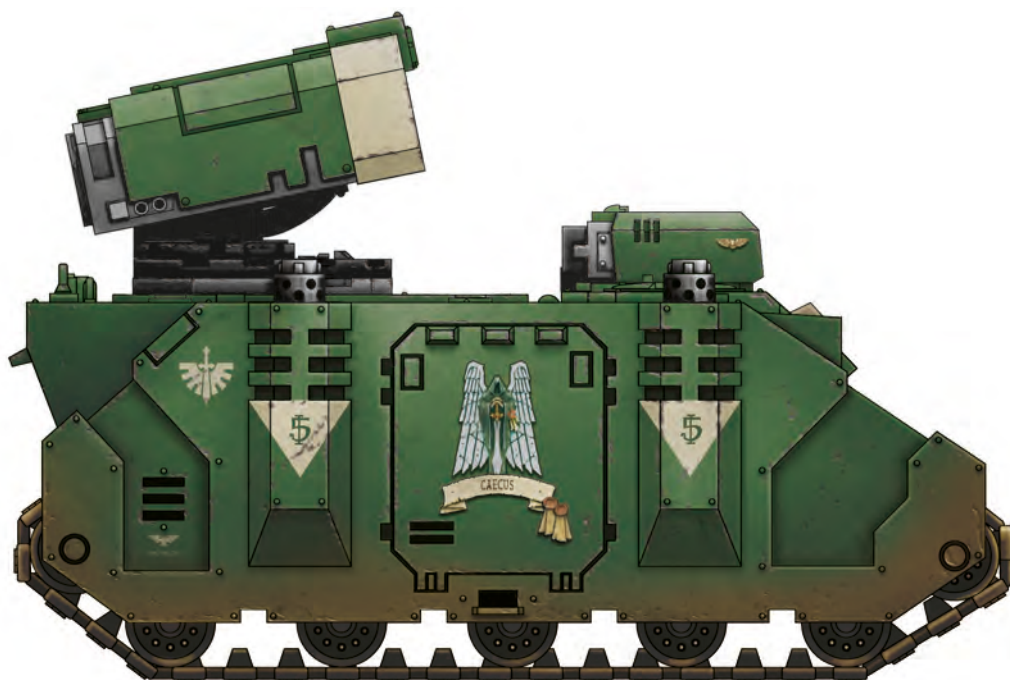

Whirlwind attached to 5th Company.

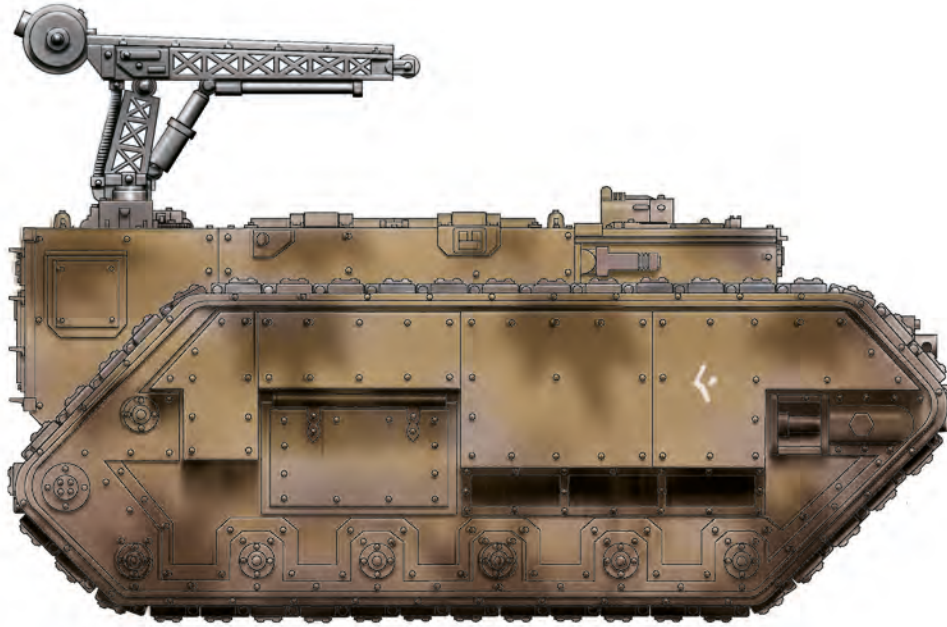

Trojan towing tractor, destroyed by artillery fire in sector 53-48.

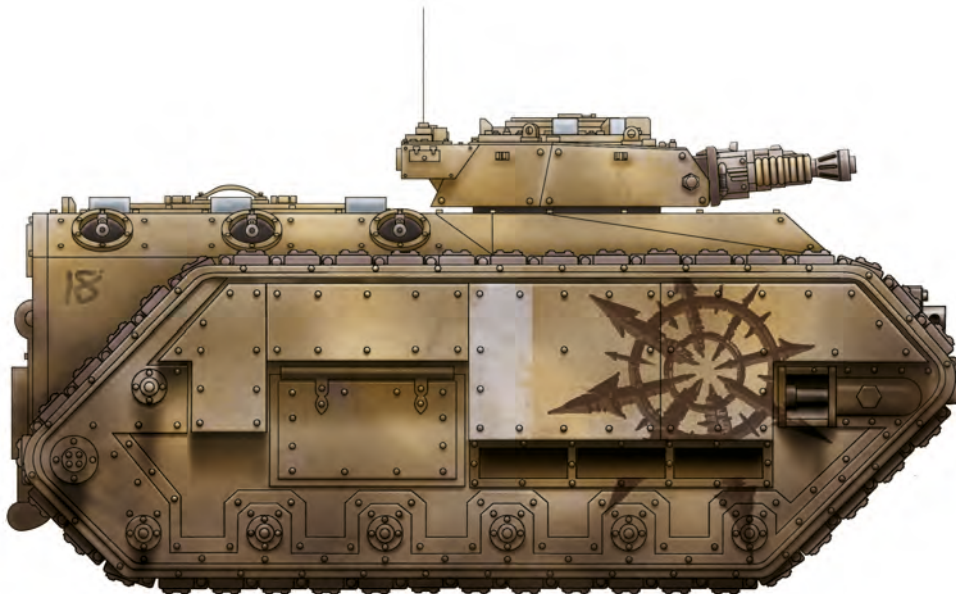

Chimera armed with a heavy flamer. Its original numbering has been removed and the number 18 added.

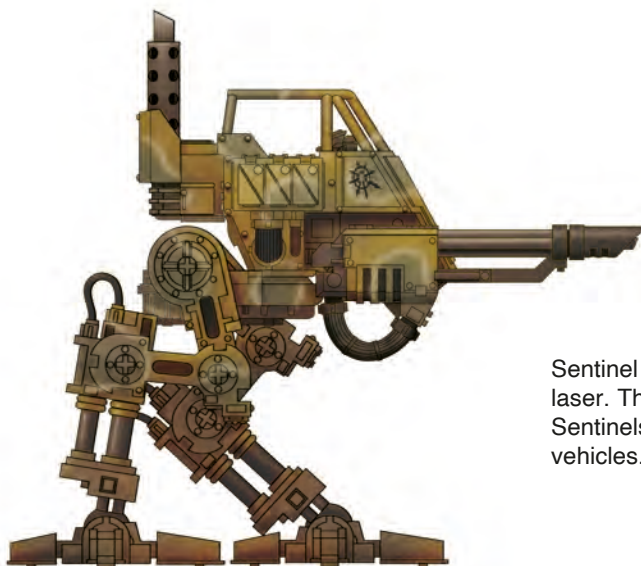

Sentinel scout walker armed with a multi-laser. The Vraksian renegades deployed many Sentinels as reconnaissance and support vehicles.

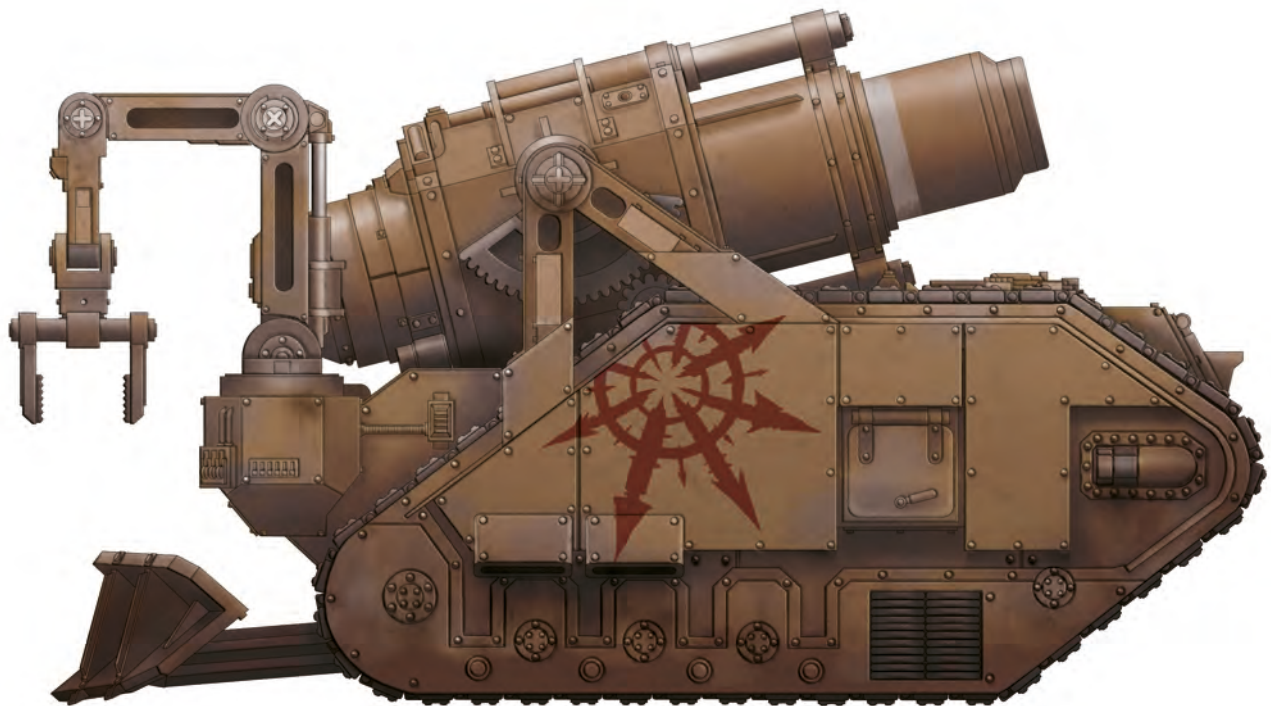

Captured Bombard heavy siege gun daubed with the heretical eight-pointed star. The enemy were also well-equipped with heavy artillery.

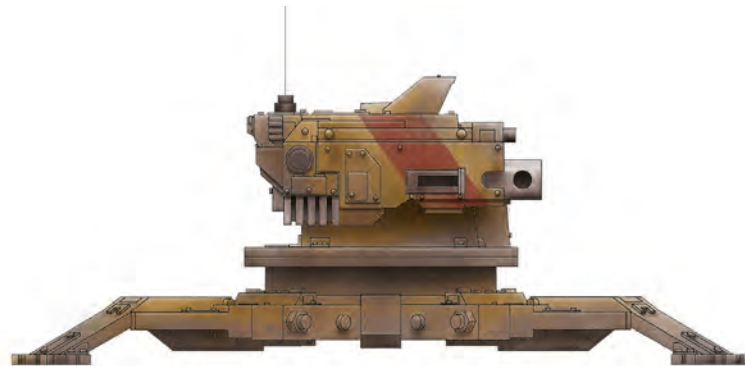

Heavy Bolter armed Tarantula sentry gun. These were deployed on the front line to cover the approach across no-man's land.

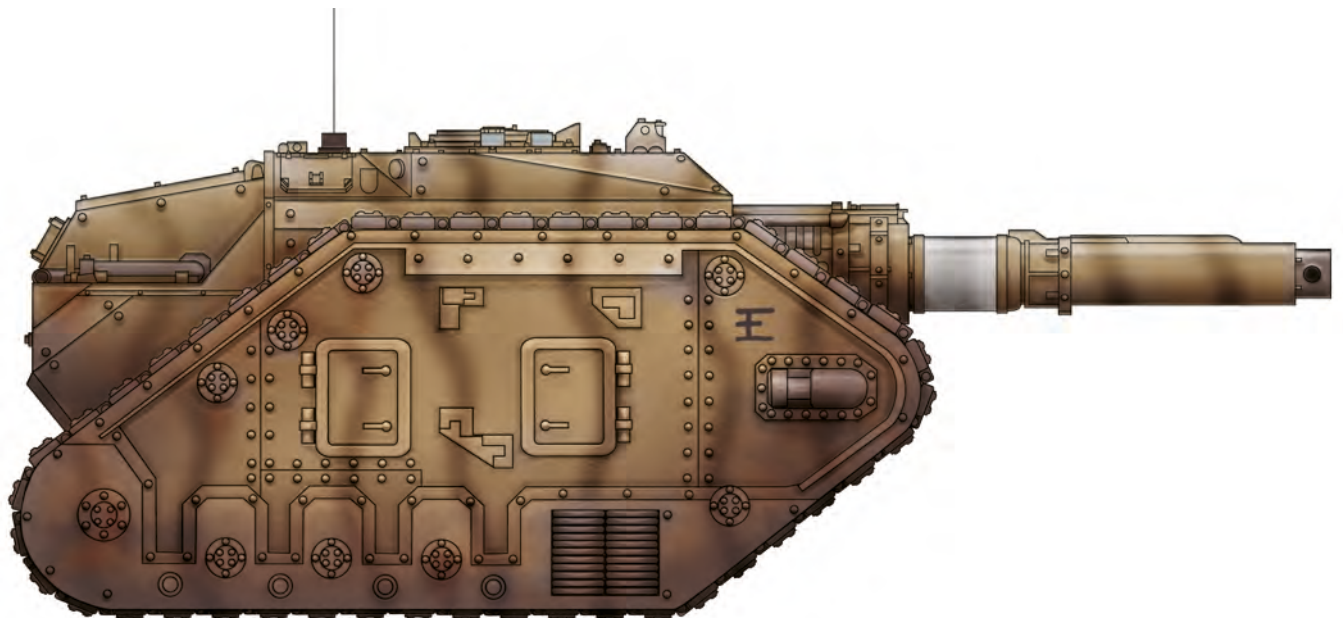

Destroyer tank hunter. Although rare vehicles, Vraks' stores contained a few of these. This vehicle was destroyed during 11th assault corps' attack in sector 52-41.

# CHAPTER SIX

## BREAKTHROUGH

*"To retreat is defeat. Advance! Advance! In our death lies victory."*

Captain Denos, 19th company, 468th regiment.

### The Big Push

It had been nine years since the siege of Vraks had begun. By now the 88th Siege army should have been entrenched at the inner defence ring having cracked the defences of the first two rings, and it should have had the Citadel itself within the sights of their heavy artillery. But nine years of war had not gone entirely to plan. The 88th army had been forced to request more men. The success of the Dark Angels attack gave cause for new hope, and Lord Zuehkle saw the chance to redeem earlier failures with a decisive breakthrough.

The addition of a new line corps with three fresh regiments gave his commanders on the ground the extra forces they needed to mount an unstoppable offensive. Due to the heavy losses the siege regiments had become too weakened, and their commanders had become content to hold the line, harass the enemy and look to make a series of uncoordinated small gains, in the hope that one of these would one day be the first crack in the dam. But Lord Zuehkle was running out of time, he had been given twelve years to complete his mission and the resources of Krieg had poured onto Vraks in vast quantities. He ordered the three new regiments, and those already in the line to plan and execute a big push, an all out offensive that applied constant and sustained pressure on the second defence lines over its full frontage. This would draw in the enemy's reserves and then destroy them under the artillery bombardment or in powerful infantry attacks. By sustaining the pressure, the enemy would eventually have to break somewhere. When they did an assault corps would be ready to pour into the gap and smash through to the inner defence line. If the breakthrough attack was fast enough they may even be able to drive into the inner defence line and establish a foothold before the enemy had a chance to dig himself in again.

Time would be needed for the big push, to organise the attack plans, position and provision the artillery, bring battered companies up to strength with new men and supplies, to prepare the battlefield by clearing minefields, and most importantly, stockpile sufficient

shells to make the preparatory bombardment the heaviest of the war yet. It was a massive organisational task for the staff of 88th army headquarters, but when complete, the army would be ready for a great battle, perhaps it would be the turning point of the war. The time for the start of the new offensive was set as 101822.M41.

The defenders could not fail to notice the build-up for the attack. Patrols and observation posts reported the increase in troop numbers at the front and the stockpiling of arms and equipment. In response, shells rained down on the Krieg trench lines in an attempt to 'spoil' the preparations now underway. Krieg's guns replied in their counter-battery role. Every gun destroyed now was one less to rain destruction down on the attack when it finally came time for the infantry to go over the top.

Meanwhile the artillery plan for the attack was being finalised, and just as in earlier attacks it was highly complex, requiring accuracy and timing from each battery as it either sort to lay smoke, destroy the enemy's razorwire or tank traps, suppress enemy infantry or hit their guns, bunkers or roads deeper in the defensive zone. Whilst the artillery were preparing, the infantry officers were issuing detailed instructions for the attack. Each company was given its objectives, and returned detailed plans of how its platoons would be deployed to achieve the objectives. As zero hour approached activity became feverish. At 089822.M41 the preparatory bombardment began in earnest. Every gun in the 88th Siege army roared out, lighting the sky with muzzle flashes as they poured high-explosives down on the defenders. All day and all night the guns fired in an attempt to break down the defenders' resistance.

Whilst outside and above them the ground shook with the force of explosions and the air throbbed with concussion, the defenders were hidden underground in their deep dug-outs, under layers of earth and ferrocrete. The defenders grimly awaited the coming assault. As their frontline was shrouded in a blanket of flames, smoke and dust that was visible from orbit.

In darkness the communication trenches began to fill up with troops. The first wave was in position. The second wave was also ready, crowded in shoulder-to-shoulder, heavily laden with extra equipment, grenades, ammunition and rations for the coming battle. As lightning storms crackled overhead, and the orange jet of flames from the unceasing bombardment lit the Van Meersland Wastes, a force of over two million infantry men was now ready to attack.

The darkness soon gave way to the first weak rays of dawn's light. For the most part the objectives across no-man's land could not be seen for the heavy smoke clouds now drifting over the front line. In a last effort the guns increased their tempo, hammering their last rounds into the defences in a wall of shrapnel and flame, and then it ended. The fury of the barrage stopped, and for a brief second there was silence.

### Day One

The attack order flashed through every vox-caster set in the forward trenches, and was relayed to the men. In a scramble of boots they were up the ladders and over the parapet, surging forward in a tide across no-man's land. Commanders watching from the rear only briefly saw their men before they vanished in the smoke and dust. For the regimental commanders there was nothing they could do now, the great machine of war was rolling and it was up to the companies, platoons and squads to fight their way forward. From their command bunkers they would listen for vox-reports of progress and try to gain a picture of what was happening at the front – where the attack had succeeded or where it had failed. Where reinforcements were needed, and where the enemy might be breaking.

Across no-man's land the enemy were responding to the lifting of the bombardment. They knew what was to follow, and ran pell-mell to crew their weapons. In many places their defensive positions had vanished, blown away in the tornado of the four day bombardment. Instead they scrambled into shell holes and levelled their weapons. Mere smoke could not stop bullets or las-blasts, and even though

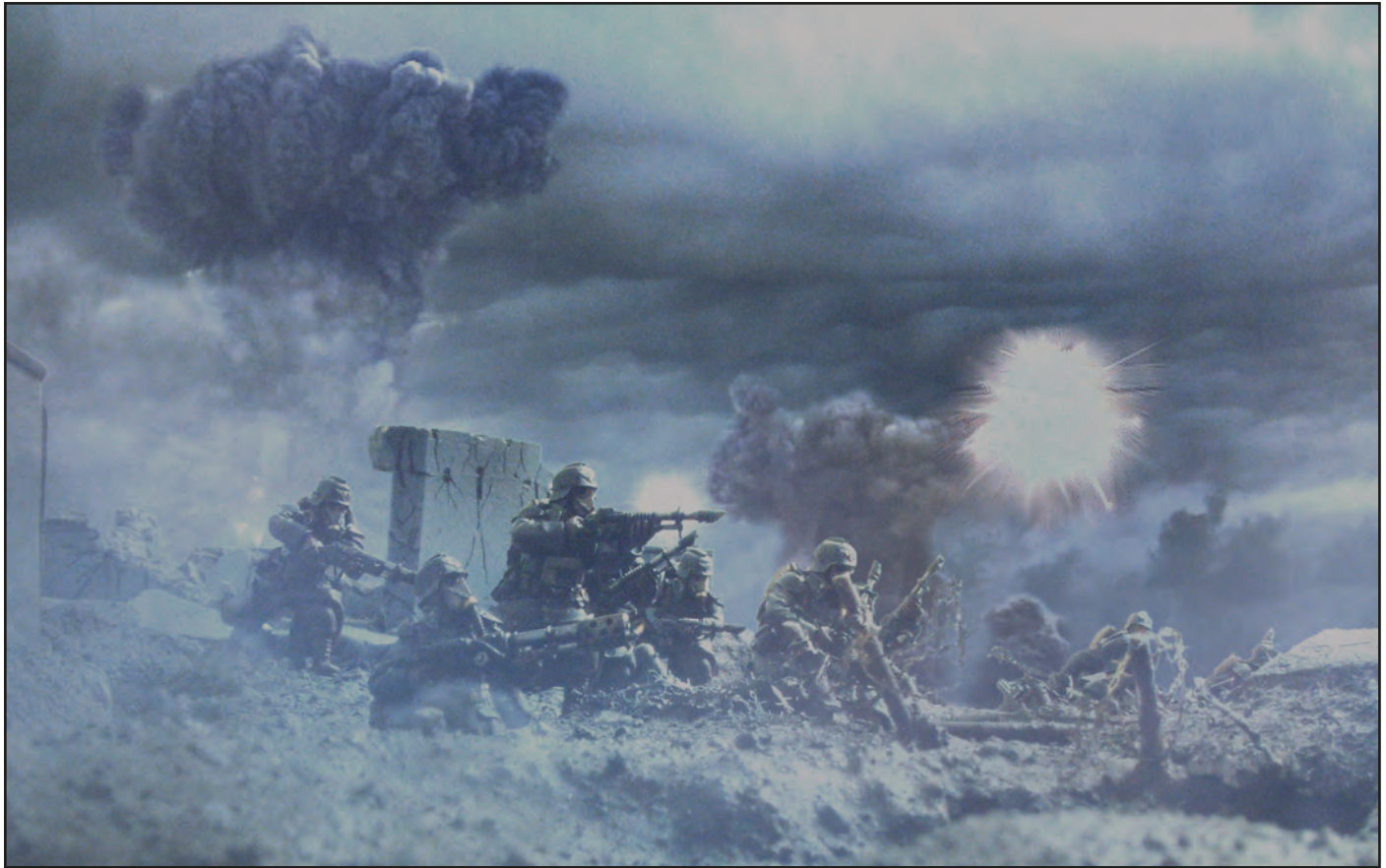

*Top: A starshell explodes as a squad of infantry surge through a wrecked defence line during a night raid.  
Above: A near miss as a sheet of flame flashes past a Lemman Russ of 105th Tank company during the breakout from the outer defence lines.*



*Top: Leman Russes of the 14th Tank regiment advance through the smoke and dust of an artillery barrage.  
Bottom: A heavy mortar is towed to a new firing position during the advance to the second defence lines.*



*Top: Heavy Metal. Krieg tanks operating in no-man's land.*

*Bottom: Heavier Metal! Super-heavy tanks add their weight to the tank regiments' attacks.*

targets had not yet come into view, they opened a lethal hail of grazing fire. Inside the enshrouding clouds of smoke and dust, the advancing guardsmen could not see their enemy, but the sudden rattle of heavy stubbers, the bark of heavy bolters and the staccato bursts of autogun fire soon told them that the enemy were present. Men started to fall, but the attackers pressed on.

Soon the defensive batteries that had not been knocked-out opened up with their own battle fire. No-man's land had long been pre-sighted, so the response was rapid and accurate. Shells started to crash down into the advancing Krieg ranks, as the defender's fire increased, summoning up the maelstrom of destruction again. In no-man's land whole squads were being wiped out as the salvos created a wall of shrapnel. As the artillery fire hammered down it caused the utter collapse of the 158th regiment's attack in sector 50-45. The first attack wave was already falling back in the face of intense fire. The Commissars amongst the assault squads demanded that the men stand firm and push on, summarily executing the first men to take any steps backwards. In return, several Commissars were shot out of hand by their own side as the shredded assault

companies scurried back to the safety of their own trenches. At the parapet they were met by the second wave, moving forwards to begin their own advance. It was pandemonium as the advancing and retreating units collided, choking the trenches with more men than they could accommodate. Fighting broke out as the officers of the second wave tried to force a passage forwards. After only a couple of hours the 158th regiment's attack had disintegrated into a shambles. For the regiment's abject failure, its colonel and his staff would be arrested and eventually executed. The regiment was then disbanded by the 88th army's commissars. All the survivors would be sentenced to serve amongst the penal legions.

In other sectors there was more progress. The Krieg guardsmen were pushing on regardless of heavy losses. In places they reached the enemy lines and overran them, bayonets fixed. In the welter of bloody frontal assaults, the overall picture of the battle was confused and patchy. In places regimental commanders would report good progress, in others failure and heavy losses. Despite this the second wave was ordered forwards, and again the guardsmen surged into no-man's land, long lines of grey men stretching

towards the horizon.

As the battle progressed it became clear that most of the enemy had held their positions. Where they had been overrun, they had only fallen back deeper into the defence line and manned new positions. The 34th line korps attacks seemed to have achieved the most gains. In the 291st regiment's sector they had achieved complete artillery supremacy, having destroyed just about all the defenders' guns. Their infantry had now completely overrun the enemy's front line and was pushing on, continuing the attack even in darkness. The 88th army seized upon this success as the point of maximum effort for tomorrow. The 11th assault korps had so far been held in reserve, and now it was ordered into position to begin a fresh attack through the 291st regiment. Its men clambered aboard their tanks and packed into Gorgon assault transports. It would take a day to prepare the attack, so the 291st regiment would need to consolidate its gains tomorrow, and could expect relief on day three.

As usual the cost of the first day's attacks had been appallingly high, and many companies were already faced with manpower shortages. Those that had won a foothold would need to hold



*Above: The big push. Gorgons of the 11th assault korps await the order to advance on day three of the offensive.*

on until reinforcements could be rushed to them. Day two would be a day of consolidating those gains and holding against the inevitable counter-attacks, before day three saw another mighty effort. In truth the gains had again been slim. The enemy had fought hard, in places with fanatical zeal, to hold his ground, but the attack must continue.

### Day Two

Day two was a day of consolidation and disjointed attacks, as each Krieg company tried to secure its own position or push on to the objectives they had failed to carry yesterday. As the artillery duel continued to rage overhead, the men fought separate battles from their ad-hoc positions. Here and there a ruined bunker was assaulted and harried, only for the enemy to counter-attack and recover it. Dug-outs had to be cleared of surviving enemies with grenade and bayonet.

Where an attack had captured an enemy trench line, it was sealed off at either end to prevent the enemy from attacking along the trench. Heavy weapons had to be dragged forwards and positioned to repel the counter-attacks. In sector 56-50 Lieutenant Kada's men, 8th platoon, 14th company, 158th regiment, had achieved just such a gain. He had set out as part of the second wave with a full strength platoon of sixty men under his command. Crossing no-man's land under fire it had been reduced to thirty three men, who now bravely held a section of trench line that had only been captured after the lieutenant had personally assaulted the defenders' heavy bolter position, crawling forwards through shell holes littered with the dead and wounded of previous attacks, before leaping up and emptying his laspistol into the weapons crew at close range. Killing both the gunners, he had then jumped down into the trench, turned the gun along the trench and cut the enemy riflemen on the firing step to pieces. He had then ordered his own men, still sheltering in no-man's land, forwards and the trench was theirs. Now he had to hold on. Artillery fire was still landing close by, which side was firing it he couldn't tell. That night, Kada's men cleared a dug-out and built barricades across the captured trench.

At dawn the enemy attacked to recover the trench, throwing grenades over the barricades. Again the captured heavy bolter poured fire down the trench to drive the enemy back. Each time they appeared a burst of fire at point-blank range sent the attackers diving back into cover. By midday Kada's

men were exhausted and running low on ammunition. Enemy mortar fire was gradually getting closer. Urgently needing reinforcements the lieutenant and his aide set off back into no-man's land to recover a vox-caster. Leaping from shell hole to shell hole he found his vox-caster operator's body and pulled the device off his back. Crouching in the crater he called through to report to his company commander, but could get no reply. He tried the company next to his own in the line, and again could raise no response. Finally he got through to somebody – a quad-launcher battery commander, who agreed to relay his situation and position along the chain of command. As Lieutenant Kada made his report, an enemy sniper spotted him and his aide crouching in a shellhole. The sniper's first round hit the lieutenant in the neck, mortally wounding him. Kada sprawled in the mud, writhing as blood soaked his greatcoat. His aide dodged away and scurried back to the trench, under sniper fire all the way, to report their officer's death and tell the platoon that help was coming. By now mortar rounds were impacting on the trench's parapet, and most of the men sought shelter in the captured dug-out, leaving a few unlucky sentries to brave the fire and warn of any more enemy attacks. It was a desperate situation. The 8th platoon were down to just nineteen survivors. The courageous nineteen held off two more attacks before their lieutenant's sacrifice was eventually rewarded.

Across no-man's land came a squadron of Centaur carriers, bouncing along, each carrying a squad of heavily armed grenadiers. With heavy stubbers laying down a suppressing fire, the grenadiers disembarked into the trench, and soon set about expanding the foothold, attacking along the adjoining trenches with grenades and flamers. Soon the enemy had been thrown back and despite continued mortar fire the trench was secured. In darkness a new platoon replaced the surviving fourteen members of Lieutenant Kada's 8th platoon. The exhausted men recovered their officer's body as they withdrew back to their own trenches.

Small actions such as Lieutenant Kada's were being fought all along the front on day two, as 88th army sort to secure the gains it had made by the sacrifices of the first day. By the end of day two, several regimental colonels were requesting that the offensive be called off, or at least scaled down. At this rate of attrition their regiments would soon be annihilated. The 88th

army command, and in particular Lord Commander Zuehkle, would not – could not – consider such a request. The offensive was too important to set aside because of dreadful casualties. This was Zuehkle's last throw of the dice, and a major offensive could not be held-up for detailed situational analysis. Speed of action was all important, the longer follow-up attacks were delayed, the longer the enemy had to dig himself in, the more painful the eventual attack would become. No, the offensive's momentum (slow though it was) was inextricable. More attacks must go on day three. The 88th army was hurting, but the enemy must also be feeling the pain.

### Day Three

As ordered, fighting continued along the entire front but the focus of the 88th army's efforts today would be in the south in sectors 51-41 and 52-41, where 11th assault corps was being committed to the attack. Soon the rumble of tracks and engines could be heard as the tanks rolled forwards. Slowly crawling across the pitted wastes of no-man's land, the tank companies fanned out into battle lines and began their thrust. Behind them followed the massive Gorgon transports, these land leviathans were each packed with a platoon of fifty men, ready to disembark and charge the enemy's positions.

After the previous counter-attacks, the enemy was now only holding a loose line of smashed bunkers, walls and shell holes. Soon those positions would be overwhelmed as the Gorgon carrier's ramps crashed down and hordes of Krieg guardsmen disembarked. The first thin lines could not hold the crushing weight of 11th assault corps, attacks for long, and by mid-morning the tanks and infantry were advancing again. It seemed that the breakthrough that would destabilise the entire second defence line was close.

But the enemy commanders were not ignorant of the situation on the ground. They too had identified 291st regiment's penetration as a dangerous threat, and had had a day with which to reinforce the sector. Executing a renewed counter-attack, equipment, formerly hidden away deep in a store house, was now pouring forth to meet 11th assault corps. Leman Russes, Chimeras, new Basilisks, Medusas, even a squadron of twelve Destroyer tank hunters had been ordered to attack. As the vanguard of the Krieg assault corps rolled steadily forwards, enemy resistance began to increase. Tanks exchanged fire at

long range whilst the Destroyers were lying in wait. Soon Krieg vehicles were littering the ground, their burning wrecks spewing acrid black smoke. The enemy's counter-attack had the desired effect, by mid-afternoon the Krieg guardsmen were no longer advancing, and the enemy's armoured thrust was forcing them backwards. Tank losses were mounting, and a defensive barrage was hastily requested. The breakthrough had been halted. It had been another false dawn.

There was better news in other sectors. On the extreme east of the attack, the 3rd siege regiment of 1st line korps had now achieved its day one objectives in sector 62-48. The 3rd regiment was gathering itself for a second mighty push on day four. Tank companies of the 14th regiment were brought forwards to assist the drive.

#### **Day Four, and onward...**

The slight gains and prospective breakthroughs of the first three days could not be given up. It seemed the 88th army was intent on battering itself to destruction on the second defence lines. One regimental commander commented that High Command seemed to think the best way of smashing down a wall was by head-butting it. In the furnace of the battle that was still raging ferociously in many sectors, it seemed that the 88th army was weakening first. The new regiments of 46th line korps had been bloodied in battle. In the case of the 469th regiment they had been slaughtered, but they had also made good progress. The whole of the 88th army was now committed, its only reserves were those re-constituted companies that had been formed from the survivors and stragglers left by day one. At the new front the battle continued unabated, and would do so for the next three days. Dust and acrid smoke now hung close to the ground, visibility in many places reduced to less than 100 metres of battlefield. In such conditions it was impossible to co-ordinate attacks or get accurate reports on the fall of shells, but still the offensive persisted, locked in a struggle to the death, perhaps this would be the end of it, one way or the other, one side must give.

As company commanders fought to capture and secure local objectives, the initial momentum of the offensive began to peter-out. The rush of blood that had carried the attack this far was now draining away. Stockpiles of ammunition, especially heavy artillery ammunition, were dwindling.

Companies had been reduced to the size of platoons, platoons to the size of squads.

The offensive had raged for seven days, and still no breakthrough had come, until at 122822.M41 the 468th regiment, a new unit in its first battle launched an attack in sector 57-50. Colonel Attas, commanding officer of the 468th, devised a plan to mount a night attack against the enemy trench line now facing him. Finally, in all the confusion of battle, he managed to galvanise his sub-commanders into making a new concerted thrust, rather than the clumsy and uncoordinated thrashings of the past days that had resulted in very little extra ground captured, for the loss of a lot of men and equipment.

Colonel Attas had assembled all his artillery companies to support the plan, and managed to secure additional ammunition from 46th line korps stockpiles. The plan was that he would personally lead the vanguard of assault companies who would use the cover of a sustained night bombardment to creep forward across the no-man's land to get as close to the enemy as possible. The suppressing bombardment would be aimed at keeping the defenders' heads down and thus preventing detection. His companies would then lie low all night until first light, when the bombardment would concentrate on hitting the enemy's front lines. The most critical part of the plan would then follow. The barrage would lift, moving on 50 metres allowing the assault companies to surge forwards over the shortened distance to the enemy, not giving them time to react to the attack. With the enemy's trenches in his hands, the Colonel's following companies would then pass through the first wave to carry the attack onwards.

Korps command at first denied permission for the attack, believing the co-ordination and difficulty of moving large bodies of men at night, and then stranding them in no-man's land should they become detected, was too risky. But Colonel Attas responded that if the artillery concentration was strong enough then the enemy guns could be suppressed, even in the event of failure, and the troops had to be withdrawn, failure would not necessarily be so costly. His superiors were eventually convinced and Attas was granted permission to try his plan.

At 124822.M41 on a dark night, Attas' assault companies set off, slithering through no-man's land on their bellies, their Colonel leading them. All had to maintain silence, move carefully

and avoid detection. As they crawled, every gun in the regiment, plus those independent companies that Attas had secured for the attack, opened fire in a thunderous barrage. The shells whined overhead and crashed home. Under the cover of bursting shells the infantry crawled closer still. The sky was illuminated by a thousand muzzle flashes, but the enemy took to his dug-outs and bunkers for cover.

At the designated time, the fire concentrated on the front line. The Krieg guardsmen lay in wait as the earth a 100 metres ahead of them was battered to destruction. Then the barrage lifted, and rolled forwards, and on its heels Colonel Attas rose to his feet, laspistol and sword in hand and waved his men forwards. The lines rose as one and began to run. The surprise was complete. The enemy had little time to react. Before they could emerge their dugouts were being bombed-out with clusters of grenades. Many tried to flee, seeing that the enemy were already upon them. The Colonel vaulted across a trench, waving his men to follow and give pursuit, only to be suddenly face to face with a huge beast. Ten feet tall and build of raw muscle, the enraged Ogryn emerged from its trench to deal the surprised Colonel a smashing blow with the sledge hammer it was wielding as a weapon. The Colonel's broken body flew six metres through the air, his ribcage shattered. The crazed beast charged on through a hail of lasgun shots, roaring and battering a path forward before the blast of a well-aimed grenade launcher's Krak grenade blew the creature apart.

At one ruined bunker a shell-shocked and dazed enemy platoon surrendered en masse without firing a shot. Despite Colonel Attas' death, at dawn the second wave advanced, passing through the successful first attackers. Suddenly they were through. No more bunkers, trenches, walls, barricades or razorwire stood between the 468th regiment and further advances. The second defence line had been breached.

News of the 468th regiment's success reached high command quickly, and the reinforcements needed to widen the gap were soon on their way. First to arrive was a battery of quad launchers, towed forwards by their Centaurs, and these were set up and soon in action, firing off rapid salvos of shells to smash the enemy's last desperate attempts to counter-attack. More troops followed; tanks, Gorgons, heavier guns, squadrons of Death Riders galloping

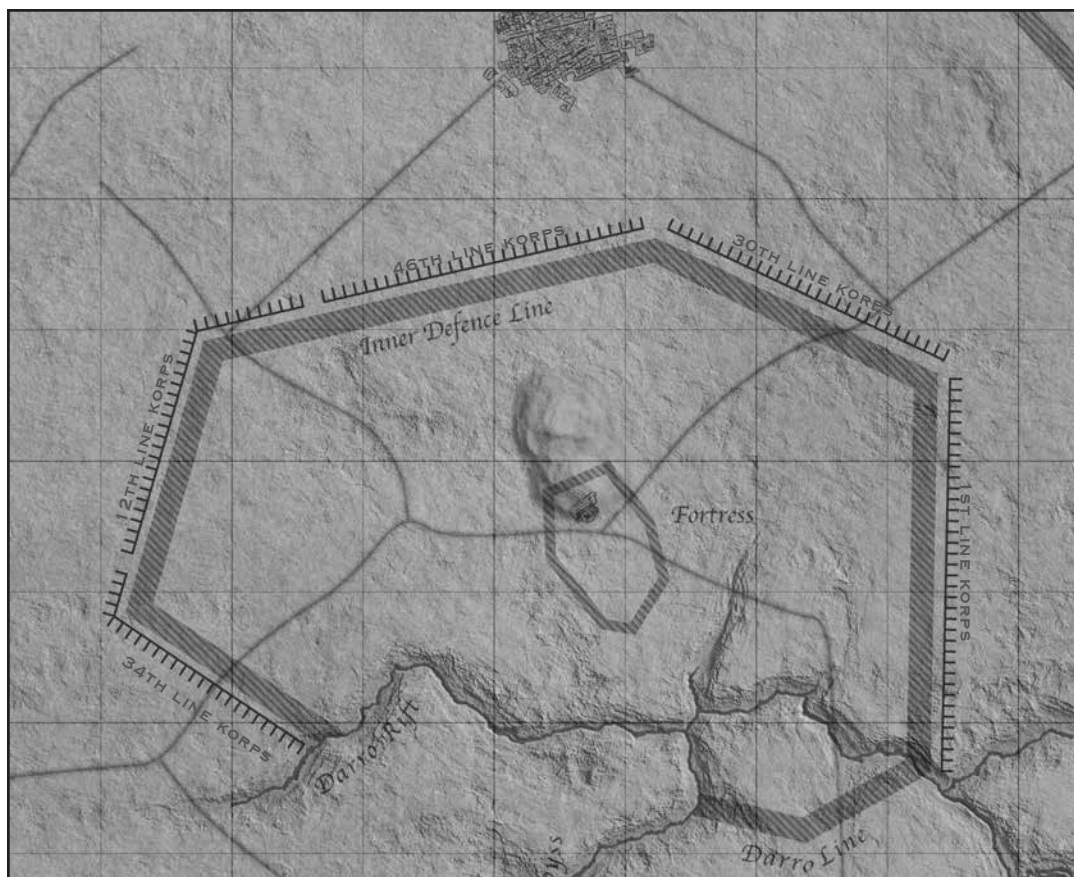

The 88th Siege army's positions as it faces the inner defence lines.

through then wheeling eastwards and westwards to attack the enemy further down the line from behind.

Just as with the first breakthrough, almost eight years before, the following days would see the second defence line fold like a house of cards. The dam had finally broken, and the guardsmen of Krieg were flowing through in an unstoppable tide. The situation was just as before, the enemy knew his positions were now untenable, he must rescue what equipment he could and fall back to his next lines. Leaving suicidal rearguards to stall the enemy advance, the defenders pulled back. One by one the siege regiments were advancing again, in some places unopposed. The 468th regiment went on to capture the ruins of hab-zone two, and was soon embroiled in street fighting with the enemy, but the regiments to their left and right were also pushing southwards, and soon the hab-zone was surrounded. Any enemy who had not escaped the encirclement were overwhelmed and destroyed.

But just as with the first breakthrough, there could be no headlong rush into the inner defence zone. The 88th army was too badly damaged to engage in another offensive against yet more strong enemy positions. It needed time to rebuild and prepare for its next trial. It needed new men, new guns, new tanks. The cost of the breakthrough had been

too great. It would again dig its way forwards, lay new trench lines and build new dug-outs and stockpiles of stores.

It had taken nine years of attrition to reach this position. Years of blood and slaughter equal to the worst warzones anywhere in the Imperium. Over four million guardsmen had already been sacrificed on Vraks, but it seemed that now the ultimate victory was within grasp. The enemy was bottled up, the front lines had once again been reduced in length, meaning that for future attacks the concentration of guns and men could be even greater. And now the Citadel of Vraks was within range of the Earthshaker cannons. For the first time the ultimate objective was within striking distance.

Within the Citadel the Vraksian rebel leaders were facing defeat as the Krieg regiments closed in on their stronghold. But Xaphan seemed not to care. The apocalypse was here, the slaughter must continue – he cared not for victory or defeat, only for death and destruction. By now Arkos had become Xaphan's closest and most valued advisor, and he counselled the renegade Cardinal that all was not yet lost. The false Emperor's armies may be tightening their noose, but there were powers in the universe far greater than that wielded by mere soldiers with guns. The dark gods would favour Xaphan if he stayed resolute and fought on. Arkos told Xaphan that many

allies were ready and willing to aid him, if he only knew how to ask for their aid. The gods could still bring him victory.

Arkos summoned his own sorcerous advisors to him. Here were men who could bring allies to Vraks. In secret the sorcerers set about a bloody sacrificial ceremony that would summon the god's aid directly to Vraks.

Krieg sentries were soon reporting unusual sightings. Strange storm clouds were gathering. The horizon was lit red by lights in the sky, that seemed to be painting the sky in blood. As the days passed, the storm grew in intensity. The crackling lightning no longer seemed to be the natural weather of the world. A huge dark storm was gathering directly above the citadel. It was a red and black mass of clouds, flicking with lightning that steadily grew into a whirling maelstrom in the upper atmosphere.

After nine years the men of Krieg might be winning their war, but the warp-spawned storm presaged worse horrors still to come...



*A Stormblade's plasma blastgun proved useful against hardened enemy bunkers. 12th Heavy Tank company, 61st Tank regiment included just three Stormblades in its order of battle.*



*A Baneblade of 8th Heavy Tank company, 7th Tank regiment during the advance to the inner defence lines.*



Gorgon heavy assault transport of the 101st regiment.



Gorgon heavy assault transport attached to the 261st regiment. This vehicle was destroyed by shellfire in sector 52-50.

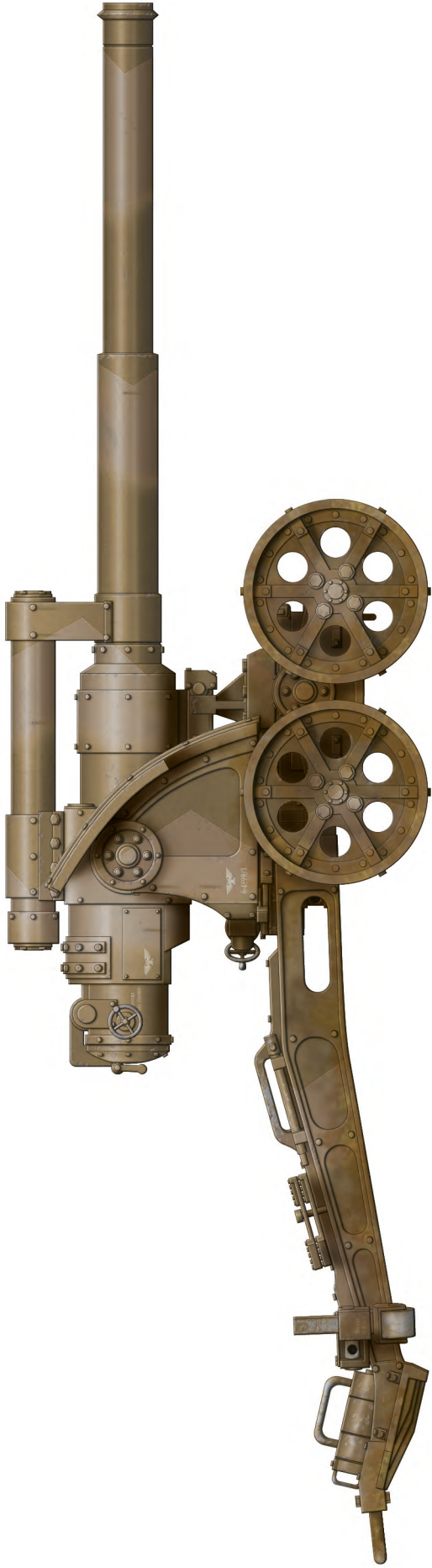

Earthshaker cannon of 31st Independent Artillery company.

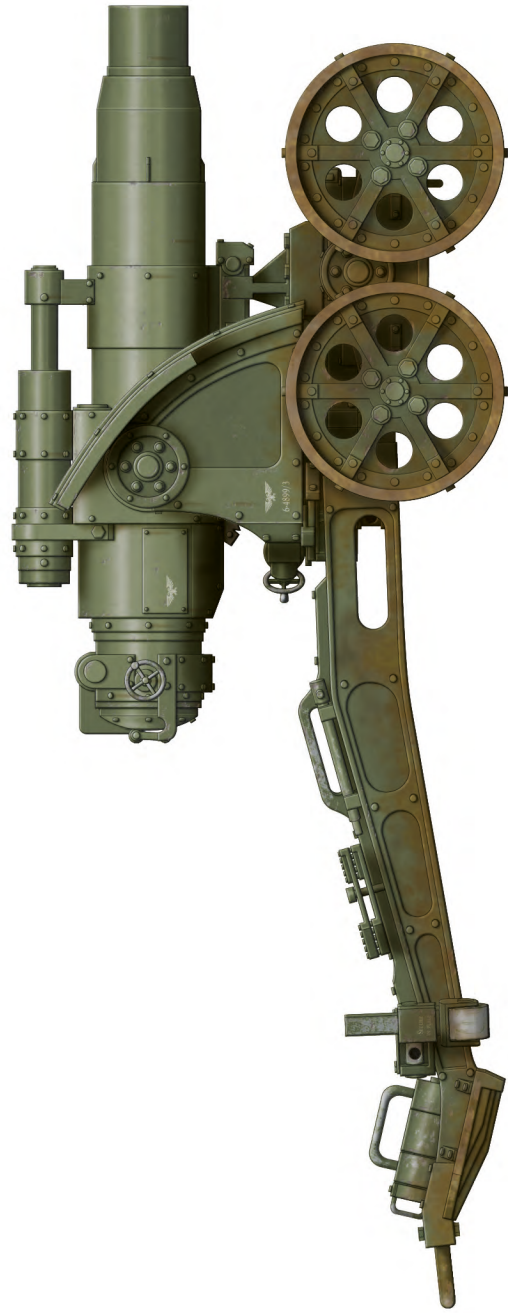

Medusa siege gun of 23rd Siege Artillery regiment.



Leman Russ Exterminator of 3rd company, 7th Tank regiment.

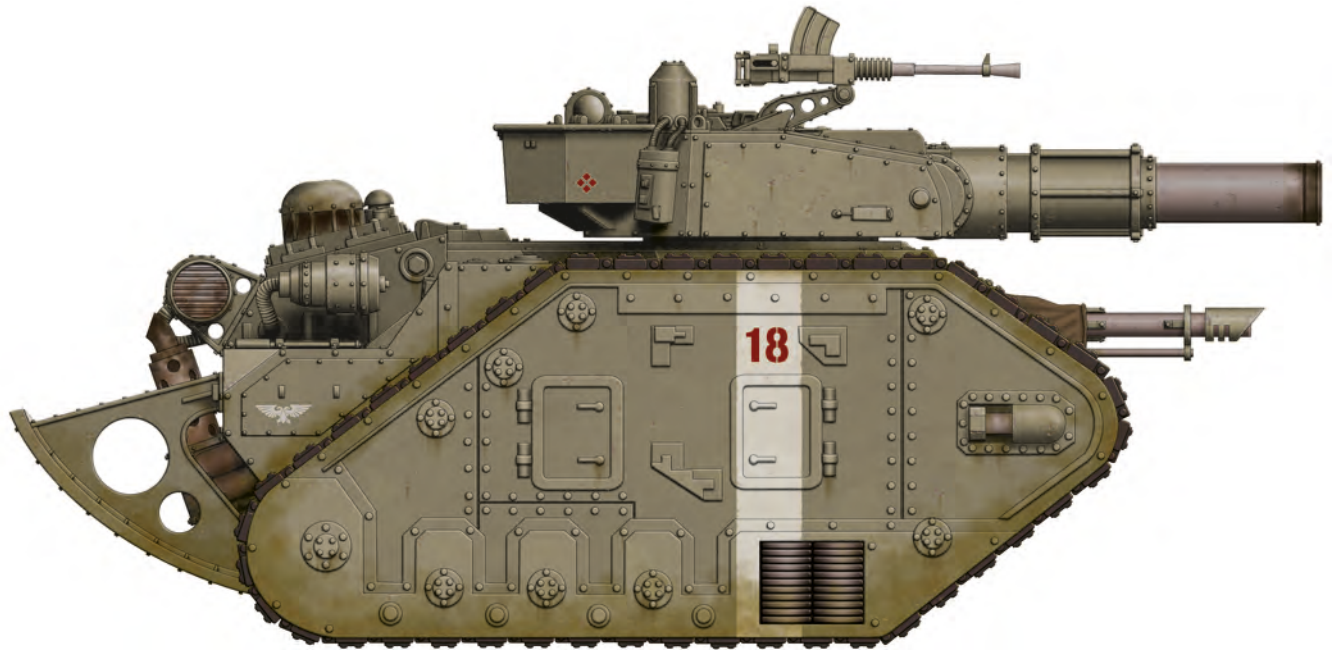

Leman Russ of 1st squadron, 8th company, 7th Tank regiment.

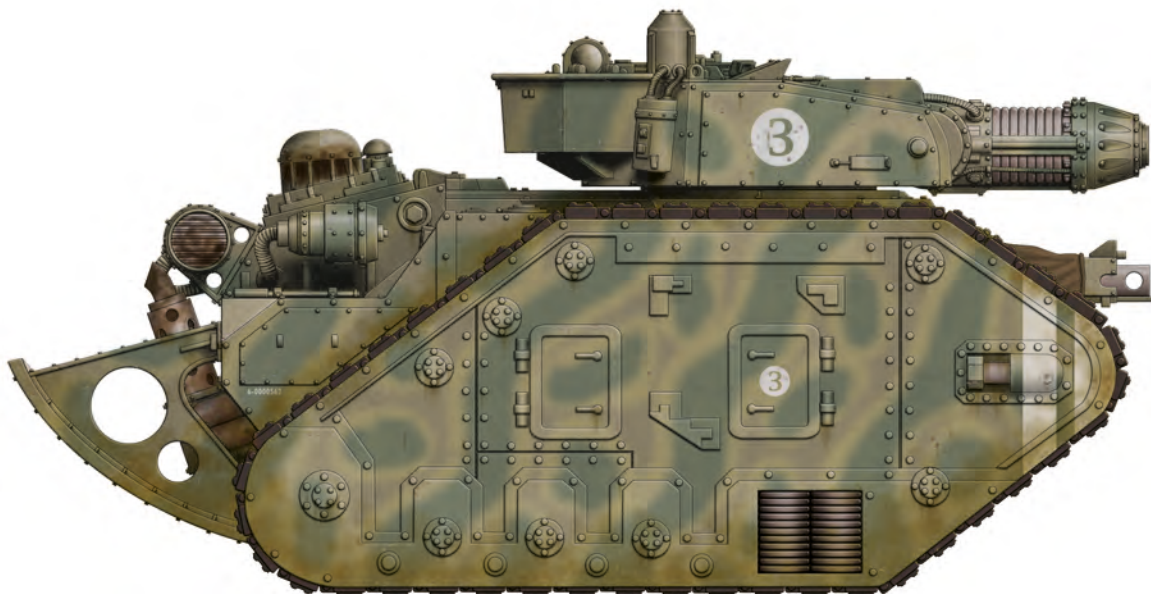

Leman Russ Executioner of 3rd company, 11th Tank regiment.



Macharius heavy tank of the 61st Tank regiment, 3rd heavy company, 1st squadron.

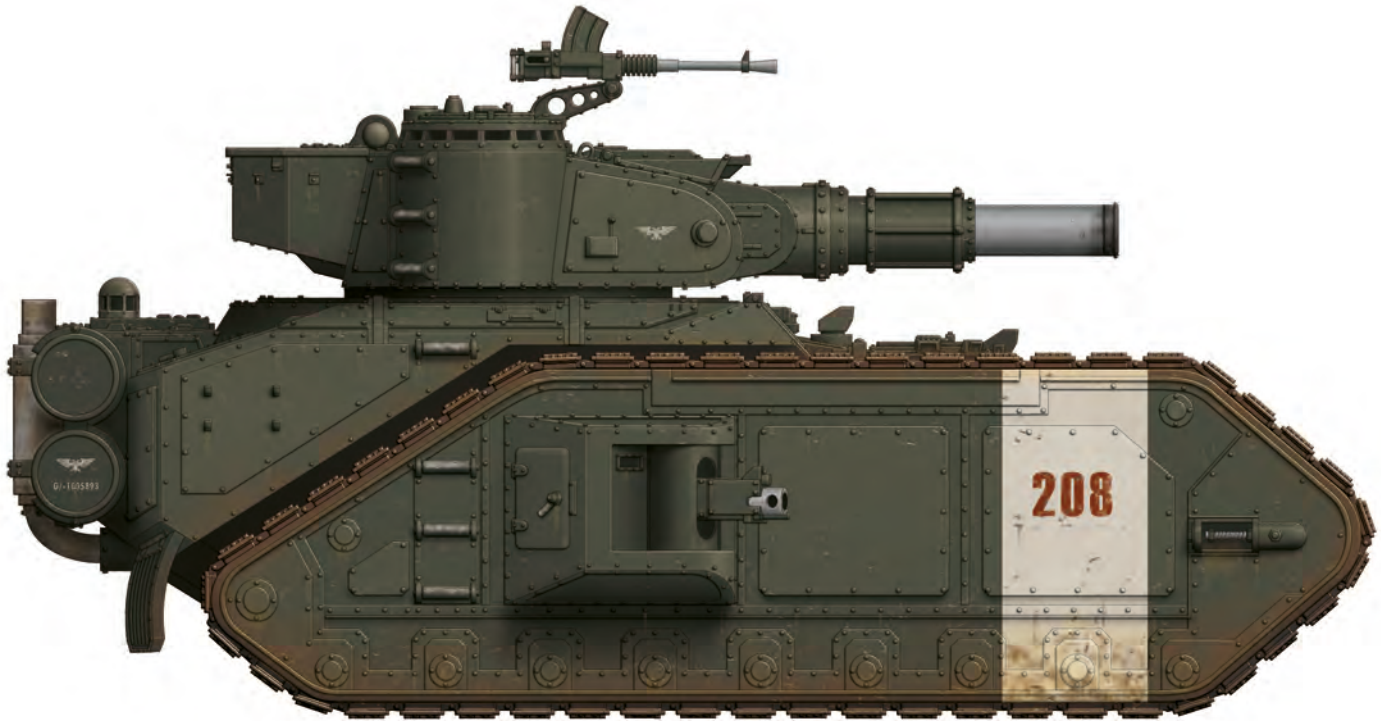

Macharius heavy tank of the 14th Tank regiment, 8th company, command vehicle of 2nd squadron.  
This vehicle was destroyed by enemy artillery fire in sector 47-45.

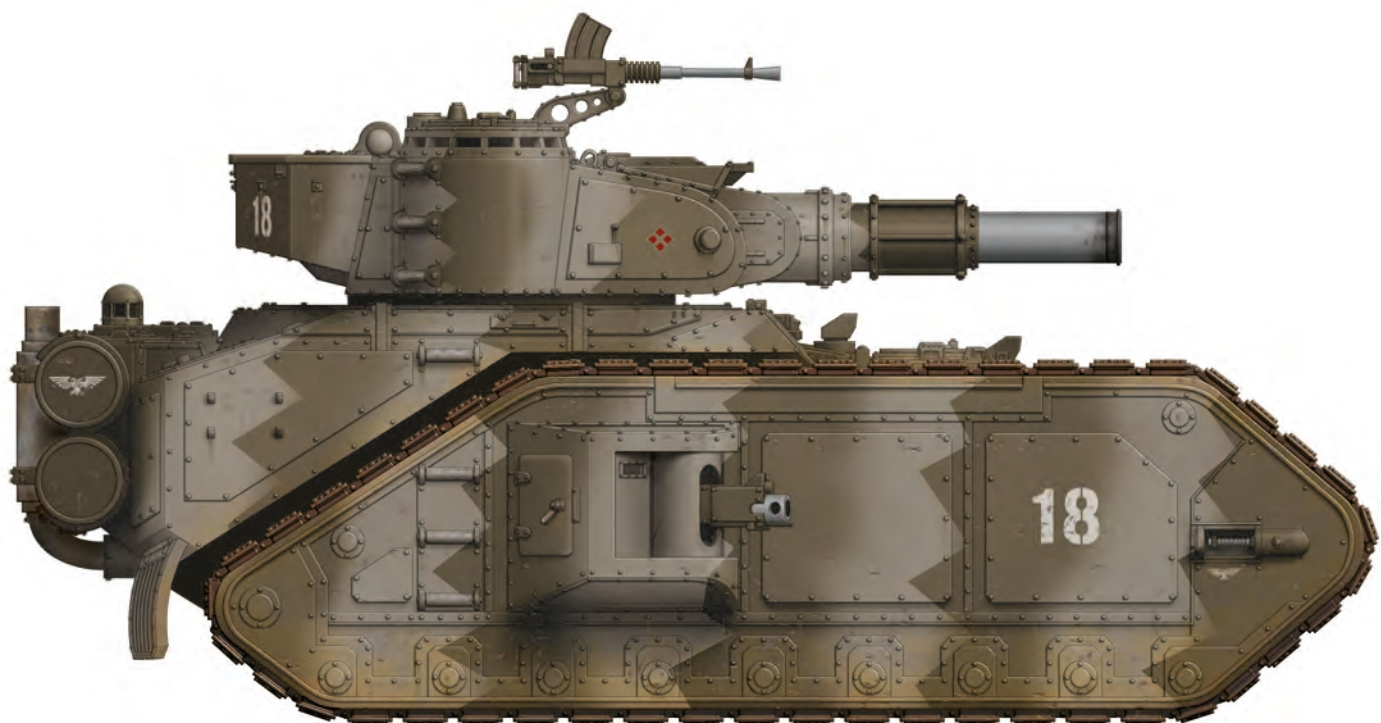

Macharius heavy tank of the 11th Tank regiment, 1st company, 8th vehicle.

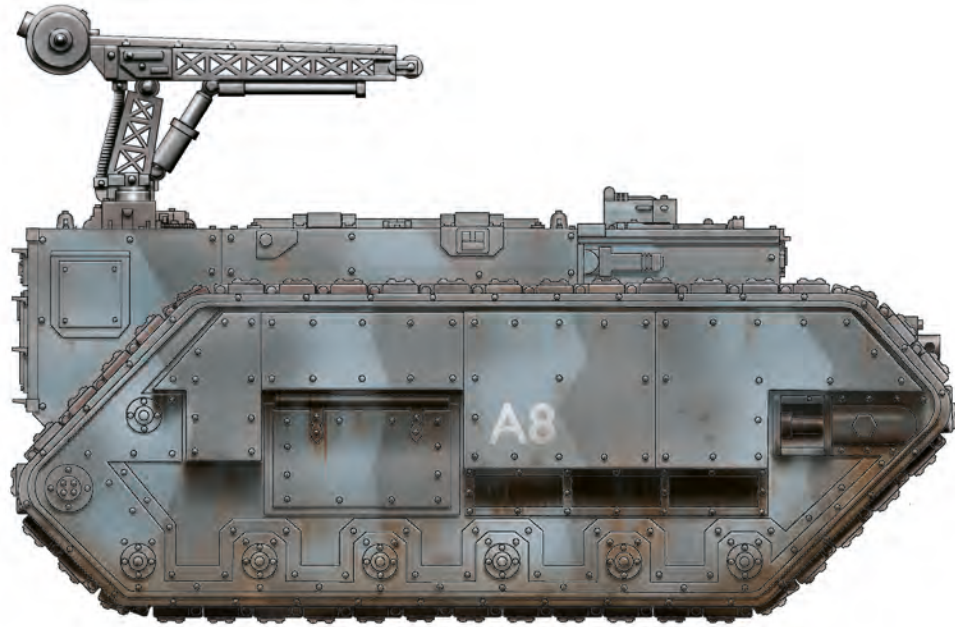

Trojan ammunition vehicle of the 61st Tank regiment.



Cyclops remote control demolition vehicle of the 156th regiment.

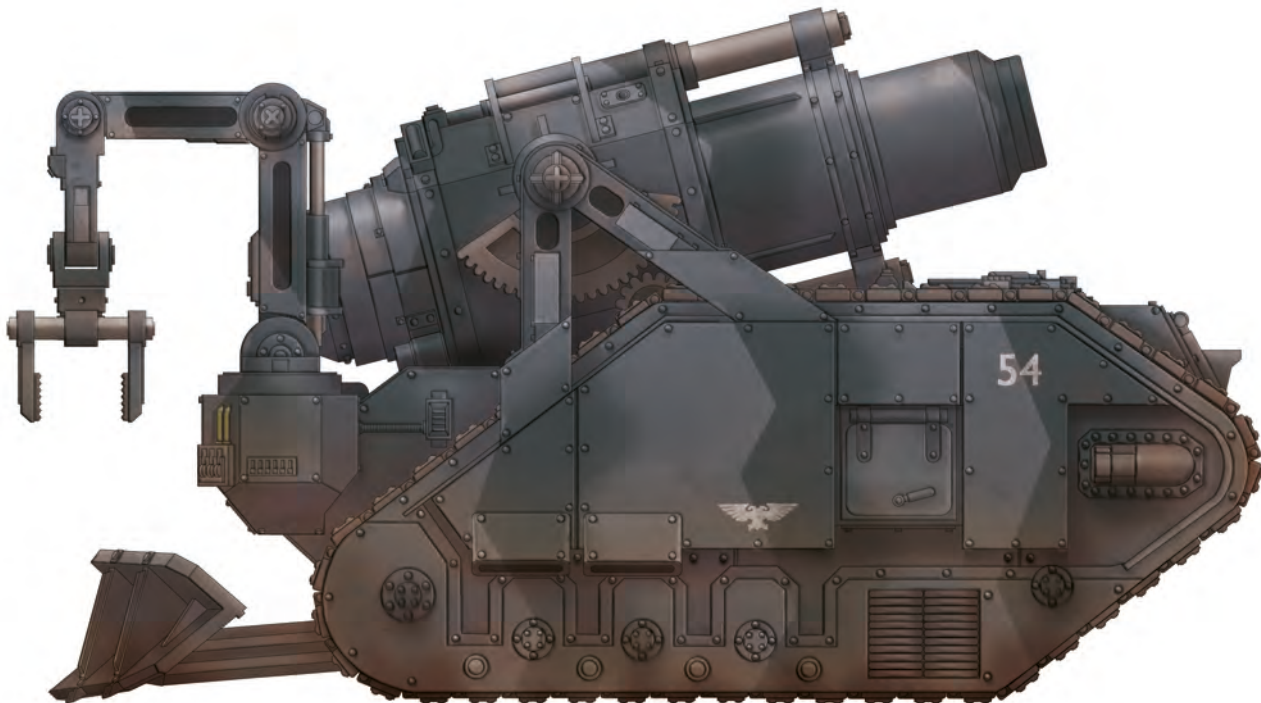

Bombard heavy siege mortar of the 3rd Siege Artillery regiment.



# **FORCES OF THE IMPERIUM**

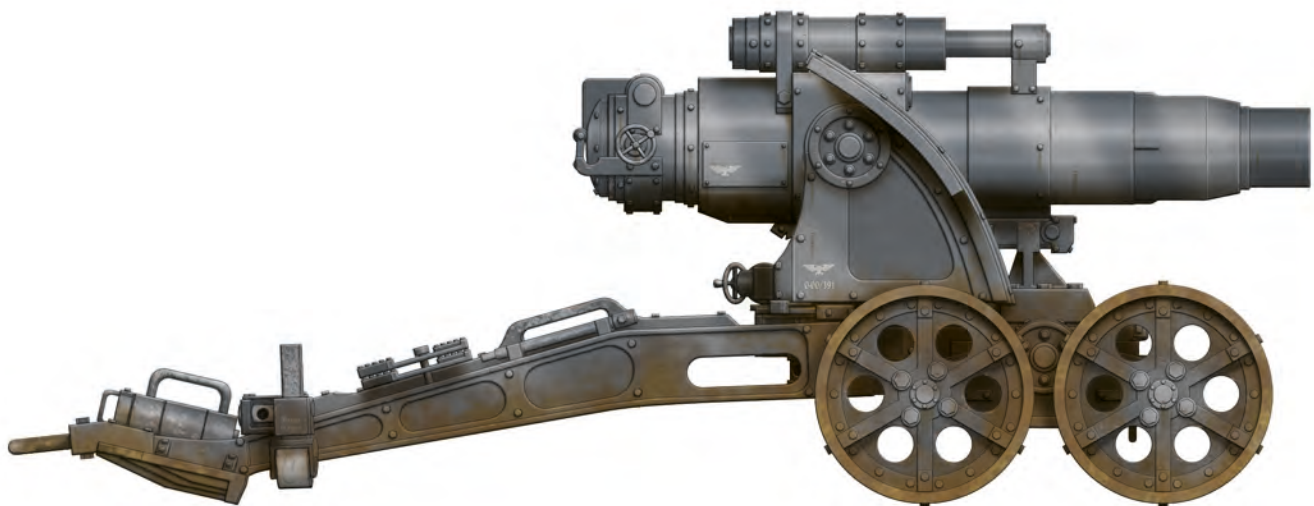

Medusa siege gun of the Krieg 143rd regiment, P battery, 378th Artillery company.

# THE DEATH KORPS OF KRIEG

*'In war the greatest single deciding factor is will; without the will to do so, no sacrifice is made, no initiative seized, no objective taken and no enemy vanquished - all the guns in creation are useless without the will to pull the trigger.'*

Goge Vandire  
Sermons to the Frateris Templar, Vol XIII

*Honoured sir, I have been charged by the Lords Militant to provide you with this précis detailing the origins, structure, and strategic use of those regiments of the Divine Emperor's Imperial Guard known as the Death Korps of Krieg. This information given here, I hope will be of great aid to you in the use and deployment of the Death Korps troops under your command in the forthcoming hostilities, for to paraphrase the wisdom of Warmaster Solon, "To successfully wield a weapon, one must first understand its nature." The Death Korps are indeed a singular weapon; terrifying to behold in action, unrelenting in the fray. They can fight and indeed prevail in the worst of conditions and against the most terrible of foes, but they are not a force to be used lightly or without caution.*

## **TREACHERY & TOTAL WAR: The Blood History of Krieg**

### **Before the Fall**

The world known as Krieg is shrouded in rumour and dark myth, and much of its dreadful history has been obscured and lost. The wilderness of ruined cities that span this blasted and poison-choked world point to Krieg once having been a thriving hive-world, a trading and manufacturing centre populated by billions. The rulers of this world - the council of Autocrats, bloated with wealth and corrupt with indolence, petty vendetta and vice became increasingly insular and debauched. The Autocrats' paranoia over outside threat that could shatter their dictatorial rule caused them to plough vast resources into strengthening the defences of their hive cities, building private armies and further surrounding their world with an outward facing ring of steel. Worse, the Autocrats grew to resent the influence of the Administratum on 'their' world and in particular the heavy tithes levied on them by the Departmento Munitorium, taking resources they protested were vital to their own defence. The citizens of Krieg were sadly ignorant of these slowly spiralling events and the terrible ruin the misrule of their leaders was about to bring down on them.

### **Revolt**

For Krieg, the end came in the year 433. M40, when the High Autocrat of Krieg's largest hive, the council chairman and the de-facto planetary governor, (a man so hated that his name has been purged from all records), declared planetary-

wide martial law and seceded his world from the Imperium.

Civil war had come suddenly and violently to Krieg. Much of the world quickly capitulated to the rebels' power. After the rebels' initial attacks only Hive Ferrograd remained under loyalist control, because the Krieg 83rd Imperial Guard regiment, under the command of Colonel Jurten, was in the final stages of being mustered at Ferrograd.

In response to the revolt, Colonel Jurten moved quickly to take control of the hive city from its vacillating rulers in a military coup. With the veteran Colonel at its helm, Ferrograd rapidly became the rallying point for the remaining loyalist factions.

But the situation for the loyalists was dire; the rebel forces numbered in millions and Ferrograd was soon cut-off and besieged. To make matters worse, the loyalists were on their own; the planetary defences were under the traitors' control, and strong enough that a full-scale fleet action would be required to breach them. Jurten had been informed in no uncertain terms that a fleet powerful enough to invade Krieg was simply not available. Colonel Jurten's orders were to resist with all the means at his disposal, to engage the enemy, to punish their treachery and emerge victorious - whatever the cost. So faced with the horrific odds stacked against him, Jurten came to the fateful decision that the world of Krieg would belong to the Emperor or it would belong to no one.

Deep below Hive Ferrograd was a secret Adeptus Mechanicus storage facility, and Colonel Jurten, with his loyal Adeptus Mechanicus ally, Archmagos Greel, moved to unlock the facility and unleash the forbidden and ancient weapons within. Whilst outside the siege ground on, within Ferrograd's walls the defenders laboured on a desperate plan.

### **The Purging**

On the Feast of the Emperor's Ascension Jurten unleashed his long planned counter-attack. Scores of long-range missiles roared forth from the heart of Ferrograd. The traitors helplessly watched their augers as Jurten's rockets arced high into the planet's stratosphere before detonating in blooms of blinding light, and unleashing tonnes of lethal isotopes which blanketed the entire

world in deadly fallout. For days the atmosphere became a sea of nuclear fire. Under Jurten's attack the planet's eco-system failed. The air was poisoned and Krieg's climate collapsed into storms that spanned continents. The raging fires blocked out the sun and a nuclear winter engulfed Krieg. As a result untold billions died. Those who did not perish took to their fallout shelters and began a new subterranean existence. To future generations who would live with the terrible consequences of the atomic attack, Jurten's plan would come to be known as the 'Purging'. Krieg might have been wrecked, but the purging had evened up the odds. The loyalists had been well prepared for the attack, and the traitors suffered terribly. But the civil war would go on.

Krieg's nightmare had only just begun. To the Imperial authorities Krieg was a prize no longer worth saving, its fate a red mark in the ledgers of the Administratum. Krieg became a man-made death-world, trapped in the freezing grip of a radioactive nuclear winter. The war between secessionist and loyalist devolved into a pitiless, bloody war of attrition across a planet where every inch of ground grew to be littered with trench work, rusting razorwire and shell crater, in a deadly landscape where drifting fallout ash shrouded the numberless bones of the unburied dead.

It is doubtful that the full truth of those long and terrible centuries of civil war will ever be known. Jurten finally perished, how, it is not recorded, but the descendants of those that followed him lived on, and became as fearless as they were callous. War was all they would ever know, and they were raised from birth to fight. The men that advanced great-coated and vapour-masked through the rad-wastes and blasted cities became known as the Death Korps. They existed only to endure the hellish planetary surface, in order to do their duty and to kill in the Emperor's name. Through fifteen generations of terrible bloody attrition, the loyalists slowly re-took their blasted world in the name of the Emperor, trench-by-trench and tunnel-by-tunnel - with bayonet, brutality and when needed, atomic fire. After more than five hundred years of the most nightmarish warfare imaginable and an incalculable price paid in human life and suffering, Krieg belonged to the Death Korps.

**Krieg: Engine of War**

When Krieg was officially returned to the Imperial fold in 949.M40, the event was greeted with little fanfare or regard, the grinding Leviathan of the Departmento Munitorium however took note; Krieg was in arrears, so a new title of men for the Imperial Guard was placed upon them. The Adepts were surprised when the Krieg authorities offered them not one but twenty regiments for immediate deployment, all formed, trained and equipped, and each commander requested the most hazardous war zones available.

Beneath Krieg's blasted exterior entire subterranean cities had been founded, tens of thousands of miles of bunkers and passageways dug, and a vast underworld of industry and manufacture geared specifically to the production of arms and equipment, but most of all to the production of soldiers, soldiers who proved to be as implacable as the factory lines that armed them and as pitiless as their blasted radioactive world.

The Departmento Munitorium acted quickly - the need for soldiers was immediate and these new 'Death Korps' regiments were inducted into the Imperial Guard, re-organised and issued with Commissars before being sent straight to the fray.

Their deployment proved an immediate success, (despite the misgiving of some of the regiments they served alongside). Particularly they proved superior to other regiments in war zones that mirrored the horrific state of Krieg itself; rad wastes, toxin zones and polluted ash-worlds. Imperial generals quickly learned that by deploying the Death Korps on such worlds, stalemates could be broken and advances achieved that otherwise would have required the massive expenditure of penal legion troops or the use of valuable elite forces such as the Adeptus Astartes.

Krieg was taken directly under the authority of the Departmento Munitorium and an Adeptus Mechanicus delegation arrived to review the planet's production techniques. The maximum tithe levels were enforced. Krieg's sole purpose was to turn out Death Korps soldiers as another world might mine ore or sow wheat. By the direct order of the Lords of Terra nothing was to be allowed to interfere with this purpose. This has resulted in suspect practices being tolerated - some, such as the eugenic policies designed to weed out mutants caused by Krieg's damaged biosphere, universal conscription, etc, are continuations of Krieg's centuries of civil war. But others such as the enforced use of 'Vitae-Womb' birthing techniques are little known outside of the Adeptus Biologis and are seen as dangerous and abhorrent by many

Adeptus Mechanicus Biologis.

As Krieg stands today it is a true war-world, its tithes are the maximum possible for the planet's population, raising tens of regiments every year where a comparable sized world might be expected to tithe one regiment every decade. The rate of attrition and destruction among these regiments is likewise disproportionately high, as they are assigned to some of the most hazardous battlefields and dangerous worlds known to Man.

The Death Korps have proved to be extremely effective troops, and while still only human (unlike the mighty Space Marines), they have proved capable of achieving victories against the odds by dint of bloody sacrifice, endurance, aggression and unbreakable loyalty. But despite their service record, Krieg units are not well liked by their fellow Imperial Guard commanders. But in the grim darkness and strife at the end of the 41st millennium, the Imperium of Man has dire need of these men, and the use and number of Krieg Death Korps regiments is rising, as are the resources being devoted to their creation.

## WITHOUT CEASE & WITHOUT MERCY

### Death Korps Tactical Doctrine and Regimental Organisation

#### Training

While the harsh training methods, doctrines and organisation of the Death Korps regiments are not in themselves unique among the Imperial Guard, they are both unorthodox and extreme in their application. Tested, selected and relentlessly trained almost from birth for their appointed role as guardsmen, rates of fatality and injury during training are high. Fear and weakness are not tolerated, and the minds and characters of the young prospective guardsmen are purposefully broken and remade stronger, just as their bodies are trained to withstand hardship and endure suffering that would kill others - a task already begun by the mere facts of life on blighted Krieg itself. Those that survive to the last stages of their training must face their final and most arduous test - the surface of Krieg itself.

Krieg is as deadly in its own way as any world known to Man; no part of its war-blasted wasteland has ever been reclaimed, the surface stands as a testament to their long struggle. It is a barren desert of smashed cities, ash wastes, rad-zones and fallout driven storms. Amongst the wreckage of old battlefields the training regiments march, dig trenches, clear minefields and fight mock battles against other cadets. Only those that endure are judged fit enough to take their place as members of the Death Korps.

#### Morale & Doctrine: the Cult of Sacrifice

During its great war, if Krieg's society was to survive it could not afford to sustain its weakest members - sacrifices had to be made and no sacrifice was too high a price to pay in the Emperor's service. This mindset continues to this day and it permeates every aspect of the Death Korps combat doctrine and organisation.

The character of the Krieg soldier is a legacy of its civil war. Their tactical doctrine was also created by the war. Having been raised only to fight, and having known nothing but war, generations of fighting men came to see death in the name of the Emperor as their ultimate goal. This attitude remains today - Krieg guardsmen are willing to die, as a sacrifice to the Emperor.

To the Departmento Munitorium, a Krieg soldier is a weapon to be used and expended as needed. To the Krieg commanders, battles are won by the merciless application of overwhelming force. Their doctrine dictates that any battle where their capacity to fight and willingness to die exceeds that of their enemy is a battle already won - everything else is merely a matter of time and attrition. Faith in the Emperor is instilled in the soldier from an early age. These established patterns of worship serve to amplify the culture of willing sacrifice and militancy among the Krieg, and have become known as the 'Cult of Sacrifice' amongst the Ecclesiarchy.

#### Regimental Deployment

As has been noted, regiments are raised on Krieg with great frequency. The form and composition of these regiments will differ according to the edicts of the Departmento Munitorium and the strategic needs of the moment. Krieg supplies the manpower, the Departmento Munitorium organises that manpower in various different types of regiment. Infantry regiments, mechanised infantry and tank regiments are all known, but by far the most common use of Krieg's manpower is as siege regiments. In these formations the Death Korps' philosophy of total war reaches its ultimate expression; these siege regiments operate on the principle of sustained artillery bombardments followed by a massive and unrelenting infantry assault, conducted to destroy the enemy by pure attrition. What makes Death Korps of Krieg regiments distinct however is not their wargear, but their mentality. Regardless of their assigned role, they retain the Death Korps' strengths of discipline, endurance, expertise in trench warfare and most notably their tolerance for high attrition rates and environmentally hazardous warzones.

## DEATH KORPS OF KRIEG GRENAДИER



### 1. Uniform

The grenadier's uniform is standard issue to all Krieg infantry. The greatcoat, trousers and boots are all exactly the same as those issued to other Krieg infantry, in this case in the 5th regiment's colours of all black. Under their armour, grenadiers retain their normal uniform, and so wear the same colours as the rest of their regiment.

Grenadiers are chosen from the ranks of infantry squads, usually by their Watchmasters and recommended for appointment as a grenadier. This is not a promotion, as grenadiers still carry the same rank, but they are regarded as having a seniority over rank and file guardsmen by dint of their experience and veteran status. After serving with a grenadier squad for a time, Krieg guardsman can then be returned to the infantry as a Watchmaster. Casualty rates amongst grenadiers are very high, and although service in the heavy infantry is regarded as a privilege, it is also seen as a duty. A Krieg soldier appointed to a grenadier squad cannot refuse, and adopts the skull facemask as a symbol of accepting his fate. Statistically, eight out of ten grenadiers are killed in action. The men behind the skull masks are already dead.

### 2. Armour

Grenadiers wear distinctive heavy carapace armour. This comprises of the Mark IX helmet, rebreather facemask, three piece shoulder guards, chest plate with additional abdomen plates and shin and knee guards. All are made of plasteel reinforced with a ceramite layer for additional strength, heat resistance and weight reduction. This armour is very cumbersome, and whilst the extra protection it provides is welcomed by the grenadiers, soldiers often find it necessary to discard some parts of the armour during lengthy operations.

This grenadier has stencilled his identification number on his chest plate, and his squad number has been added to his right shoulder pad. The helmet is a standard Mark IX helmet, but has a front plate attached, with the Imperial Eagle embossed to show loyalty. A part of a grenadier's

initiation into his squad, he renews his oath of allegiance to the Emperor, and this plate acts a reminder of a grenadier's duty.

### 3. Hellgun

The standard armament of the grenadier squads is the type XIV lasgun (heavy), referred to by troops as the 'hellgun' or, more rarely 'hotshot' lasgun. In effect this is an overpowered lasgun, firing in the 28 megathule range and incorporating many additional features. The weapon's powerpack is worn as a backpack, and the power cables run to the weapon's rapid discharge generator, which forms the weapon's main mechanism, where energy for each shot is stored. The heavy powerpack supplies enough power to keep the weapon firing for up to two hundreds shots, depending upon the power setting and the weapon's condition.

Hellguns require a lot of maintenance, and have a reputation as being unreliable in the field. The weapon's power couplings quickly become worn, and this leads to variations in shot power. The quick recharge generator is placed under massive stress by the increased power load passing through it, especially during automatic fire, and without good maintenance, the weapon's rate of fire will start to drop off. The overpowered shot generates a lot of excess heat, placing the barrel under stress. The heat from repeated firing can cause the barrel to warp, making shots wildly inaccurate. This is compensated for by the bulky barrel-cooling shroud, inside which are coils of heat-exchange pipes, inside which are pressurized refrigerant chemicals which flow around the barrel in a regenerating cycle (the same chemical is constantly reused). Between firing this can make the barrel shroud freezing to the touch, so a foregrip is included. Even this refrigeration system does not always prevent overheating during automatic fire, and there is a safety cut-off which prevents further firing until the temperature falls to within safe limits.

The weapon includes an advanced sight – this is a sophisticated piece of equipment, incorporating x4 magnification and a low-light infra-scope. This detects a target's heat signature, allowing more accurate targeting in darkness or even through some barriers. The careful calibrations required to keep the sight functioning mean that they are often disabled on the battlefield.

Another drawback of the weapon is its large muzzle flash on firing, giving away the firer's position.

Hellguns are not well liked by the troops, most prefer the standard lasgun, but regulations require grenadiers to carry them, and the weapon's additional impact and damage is seen as compensation for all the weapon's faults.

### 4. Equipment

As well as his main weapon, this grenadier also carries a good supply of fragmentation grenades, vital when involved in close assaults against fortified enemy positions. Although only fragmentation grenades can be seen here, he may well have additional Krak grenades as well.

The grenadier's belt pouches contain spare respirator filters, ration packs and the hellgun's maintenance kit.

Because of their extra armour, grenadiers cannot wear the standard regulator unit. Instead they wear the type V, where the regulator unit is inside a cannister that is worn on the back. This unit serves exactly the same purpose as the standard type, and contains the same filters and antidotes. Again the entire respirator is an over-pressured system.

Although the hellgun does not have a bayonet lug, the grenadier still carries a bayonet, for hand-to-hand combat.

This is Krieg grenadier 769355-637566-  
Keled of the 5th Krieg Siege regiment,  
24th grenadier squad, seen here on patrol  
during the Siege of Vraks.



### **The Siege Regiments**

These regiments are organised and formed to engage in attritional trench warfare. In the siege regiments, each Death Korps soldier is an element of the greater whole - a pebble that goes to make up an avalanche that crushes the enemy in grinding waves of men willing to die to achieve their objectives. The guardsman himself is the primary weapon; each able to maintain discipline and act in accordance with orders regardless of the odds, casualties taken or the travail of the battlefield itself. The fundamental doctrine of the siege regiment is to push forward at all costs, to take the fight to the enemy and to kill until no enemy remains. Armour, heavy weaponry and field artillery such as mortars are extensively deployed in supporting roles. Reliance on relatively light transport vehicles is seen as a liability, particularly when engaging prepared positions where large quantities of heavy weapons are present. As a result, the usually commonplace Chimera is largely abandoned in favour of the much heavier and more durable Gorgon armoured assault transport where needed for direct breaching attacks, and the lighter Centaur for rapid deployment of mobile artillery and grenadier forces. Armour and tanks utilised by the Death Korps will normally be heavily modified to better cope with extreme hazardous terrain and prolonged exposure to environmental damage. As a constant press of force is paramount to the all-out attacking style favoured by the siege regiments, man-portable heavy weapons whose deployment can stagger the pace of advance, are usually concentrated in separate detachments to avoid this difficulty. The firepower of these heavy weapon squads can then be focused to support the infantry and protect the flanks of an assault force, as well as quickly deploy to defend or fortify vital trench positions against counter-attacks. The chain of command within the siege regiments follows the standard Imperial Guard pattern with recognisable platoon and company structures of junior and senior officers, etc, although they strongly emphasize large masses of infantry over and above most regular Imperial Guard formations. Where several siege regiments are grouped together for the same front, they form a line korps, with several line korps forming an army. Regiments may also serve in assault korps, with an additional concentration of tanks and Gorgon transports used to add weight to an offensive and to exploit breakthroughs.

The best strategic use of a siege regiment is a simple and unsubtle battering ram of manpower. In action

these attacking columns consist of massed soldiery, spear-tipped by armoured grenadiers. Thousands of Death Korps troops in human waves, advancing first in dispersed formation, closing ranks as they near with the enemy line to unleash disciplined volleys of las-fire before storming trenches and defended sections. The sight alone of the seemingly numberless, ordered and sinister ranks of the Death Korps advancing, faceless in their rebreathers over no-man's land, or seemingly materialising from nowhere out of a smoke barrage has put more than one defender to flight before a shot has been fired.

### **Death Korps Officers**

Krieg regiments operate the recognisable command structure laid down by the Departmento Munitorum, with some minor local variation in insignia and designation, one example being that infantry sergeants are known by the title Watchmaster, whilst sergeants of the Death Rider companies are known as Ridemasters. Death Korps officers right up to the level of regimental command typically lead and fight from the front - this is not so much a conscious decision as a simple expression of the Death Korps mentality, as every guardsman expects to fight and die for his Emperor. To this end, officers commonly equip themselves for the front line with grenades, powerful sidearms and either a chainsword or power sword. Command squads wear their squad insignia (a C for command) on their right shoulder. Officer's helmets bear an ornate Imperial Eagle.

Unlike many other regiments that draw on a long-standing militarised culture (such as the Mordians or Jantines for example), Krieg itself has no standing aristocracy or hereditary officer class. Instead its officers are drawn from the body of the rank and file. This means that the majority of the officer cadre has been promoted through the ranks thanks to a mixture of ability, seniority and often, by dint of simple survival. As veterans of the Death Korps' way of war, they coldly regard casualties with no more concern than another commander might view a tally of expended ammunition stores, and their attitudes toward warfare are almost mechanical in nature. This has in the past led to morale problems (and very rarely even outright mutiny) where senior Krieg officers have been placed in charge of other non-Krieg regiments in a wider theatre of war. It is also a noticeable feature of Krieg officer battledress that Krieg regiments do not issue medals or decorations. To Krieg soldiers such rewards are insignificant, bravery is expected and commonplace. Individual guardsmen do not matter, and as such are not recognised with special rewards.

### **Death Korps Commissars**

As might be expected, Commissars are present in Death Korps regiments as mandated by Departmento Munitorum regulations, being the only non-Krieg natives to serve. Owing to the relatively low rates of infraction and morale problems among Death Korps regiments they more often find themselves employed in reining in any excessive 'zeal' on the part of the troops, and act as tactical advisors rather than enforcers of discipline. Indeed a Commissar is often well placed to become a voice of restraint for Death Korps officers, reinforcing the wider strategic goals of the war-zone over short-term victories through expenditure of men and material that might be needed later. Further, in theatres of war where Death Korps regiments must fight alongside other Imperial formations, the Commissars attached to Death Korps staff also find it prudent to act as the liaison between regimental commands where needed, as well as keeping a sharp eye that any acrimony between the Death Korps and other Imperial Guardsmen deployed to the same areas does not become a problem. In order to prevent potential difficulties arising, the individual Commissars assigned by the Commissariat to Death Korps regiments have a tendency to be more politically minded than most, and often go on to serve with other troublesome regiments such as feral worlders or forces raised on Ecclesiarchy worlds where fanaticism runs high.

### **The Death Korps Guardsman**

Each Death Korps soldier is fully trained to the standards expected for combat-readiness set down by the Departmento Munitorum. Particular emphasis is placed on hazardous-environment survival and endurance, and physical and mental resilience. Each Death Korps soldier is also proficient in the use of all basic Imperial Guard weaponry types, the use of grenades and explosives and the rapid and skilled construction of trench works and defences. Their hand-to-hand training is also exemplary, bayonet-drill being practiced from childhood. Accuracy (while obviously desirable) is secondary in Death Korps weapons training to fire discipline; with the ability to maintain continuous fire en masse as part of an infantry formation considered to be of paramount importance.

The character of the Death Korps guardsman is also of note; they have a tendency to be highly insular, unemotional and often taciturn to the point of silence outside of their duties. They have a well earned reputation as grim and dour soldiers. The average Krieg soldier will also display a high degree of fatalism and an unusual morbidity of habit. Death Korps guardsmen are known to carry relics,

ossuaries of bone or other memento-mori about their persons as a form of religious observance to honour the fallen. Unfortunately this psychology serves to foster isolationism (such as the fact they rarely remove their re-breather masks even when not in battle), often having the effect of generating suspicion and ill repute with other Imperial Guard regiments. The advantages of the character of a Death Korps soldier to higher command are obvious; each is highly disciplined, self-sufficient, morally reliable and more than willing to die in the service to the Emperor. It must be noted however that their unusual will to endure hardships can have the result that unless expressly ordered to do so, Death Korps units will fight on against overwhelming odds until lost, even where a tactically expedient withdrawal would be wiser.

### **The Quartermaster**

One of the most unusual features of the Death Korps regiments is the replacement of battlefield medics found in most Imperial Guard regiments with the individuals known as Quartermasters. The Quartermaster's role has its roots in Krieg's own war-torn past. In that merciless war the recovery of the arms and wargear of the fallen was of premium importance, and field medicine and battlefield triage was a luxury that could be seldom afforded for the more seriously wounded (and often a torn environment seal meant slow lingering death in any case). So it was that in Krieg's war a soldier that could not be readily brought back to the fray or at least retreat under his own power was considered a liability and to such unfortunates the 'blessings of the Emperor's peace' was given – an honourable field execution. This onerous task, along with the recovery and redistribution of the fallen soldier's equipment was the responsibility of the Quartermaster cadre and remains so to the present day.

Quartermasters are chosen from the ranks of the Death Korps by selection during training, for particular faith and mental aptitude and occasionally from individuals that have survived against the odds. Quartermasters are given additional training in field medicine, basic tech-lore, and extensive indoctrination into Krieg's denomination of the Imperial Cult. In the modern Death Korps, in addition to the ministrations of emergency treatment to injured guardsmen and the redistribution of arms, the Quartermasters also assist in evaluating the progress of ongoing battles and relay this data to their officers and command. They perform this function by monitoring ammunition expenditure, rates of attrition, counting enemy guns and so forth. Above all they still retain the function in the deliverance

of final rites on the battlefield to Death Korps soldiers they judge too badly wounded to continue, and it is the generally held belief that the skull mask representing Krieg's struggle is the last sight a dying trooper should see.

Off the battlefield a Quartermaster's task is never complete, as he moves through the detritus of battle salvaging any equipment he can, from lasguns and ammunition to great coats, boots and rebreather units, all can be recycled for use by new recruits.

### **Death Riders**

One of the most justly famous of the unique formations found within the Krieg forces are the Death Riders. Although superficially similar to rough rider cavalry units found among numerous other Imperial Guard regiments from worlds where riding mounts are commonplace, the Death Riders of Krieg are also a direct result of Krieg's centuries-long civil war. Their most singular aspect is the nature of the Death Rider mounts - the legendary Krieg steed. A highly adapted form of the original Terran horse, this animal is now the product of extreme genetic engineering; tailored for strength, endurance and aggression, with numerous additional bio-sculpted organs that allow them to survive on the most polluted and toxic battlefields unscathed. Vat-grown on Krieg under the auspices of the Adeptus Mechanicus, the animals are further augmented with sub-dermal organic armour, osmotic lungs, and a fully integrated drug injection system rigged with a potent mixture of stimulants, pain-blockers and palliatives.

The end result is that the Krieg steed is capable of incredible levels of endurance and environmental tolerance. The Krieg steed is also a weapon in its own right with its chemically enhanced aggression centres triggered at the rider's command, and virtually impossible to incapacitate short of massive bodily trauma.

The Death Riders form a special cadre within the Krieg regiments, and their inductees are chosen not only on the grounds of aptitude but also for independent thought and initiative - many future officers are drawn from the ranks of their survivors. Death Riders are equipped with a variety of sidearms and sabre-blades, in addition to the signature explosive-tipped lance found in other similar units. Death Rider companies are used both for battlefield reconnaissance, replacing the Sentinel's traditional role in the siege regiments, and as shock-troops, using their speed and impact to smash through enemy lines. They are commonly used in the role of reserves held back to break counter-attacks, or press a breakthrough themselves. They have gained their bloodiest reputation

among other Imperial Guard regiments for their merciless pursuit of fleeing enemy troops; as it is standard practice for the Krieg infantry to hold a freshly captured position while the Death Riders run down any routed defenders.

### **Death Korps Grenadiers**

The Krieg regiments maintain and train a strong and sizable force of grenadiers, forming an elite force within the Death Korps. They are drawn from veterans and survivors of decimated squads and platoons. An officer, Watchmaster or Commissar selects each grenadier for service.

Principally used by Death Korps regiments in a heavy infantry role to form the leading edge of assault waves and smash key enemy defence points during a wider attack, many grenadiers consider themselves already martyred in the Emperor's service and will not falter in their onslaught, regardless of the odds ranged against them. Intended for deployment where the fighting is fiercest, Death Korps grenadiers are equipped with heavy carapace armour integrated into the standard Krieg wargear and are armed with turbo-discharge Hellguns, linked to a high capacity power cell worn on the back. They also carry numerous anti-personal and anti-tank grenades as standard. Breaking with conventional Storm Trooper training, they are never deployed by grav-chute, and instead often carry the brunt of an initial advance on foot, or as small tactical units in rapid moving Centaur carriers. Where this is the case, as well as a high proportion of special arms (such as flamers and melta-guns, etc) they will also employ relatively unorthodox weapons such as heavy flamers in two-man teams or the squad may carry an additional heavy stubber to increase their firepower. Fatality rates among the Death Korps grenadiers are very high, but it is considered an honour to be chosen to join their ranks. Their high standards of training and equipment coupled with their mental resilience ranks the Death Korps grenadiers among the most proficient soldiers the Imperial Guard has to offer.

## DEATH KORPS UNIFORMS

Regimental colours vary based on available cloth and dye, but all Kreig regiments favour sombre colours. Grey and black are most common, with greens and browns also being used.



**Shoulder Pads.**  
Top: Regiment number.  
Below: Command squad.



19th Siege Regiment



5th Siege Regiment



Grenadier – 179th Siege Regiment



Grenadier – 19th Siege Regiment



Grenadier – 5th Siege Regiment



143rd Siege Regiment



261st Siege Regiment



158th Siege Regiment



Grenadier – 143rd Siege Regiment



Grenadier – 261st Siege Regiment



Grenadier – 158th Siege Regiment

# DEATH KORPS OF KRIEG INFANTRY SQUAD



Watchmaster  
(squad leader)



Guardsman No.1



Guardsman No.2



Guardsman No.3



Guardsman No.4



Lasgun



Lasgun



Lasgun



Lasgun



Lasgun

4 Lasgun  
Powerpacks



4 Lasgun  
Powerpacks



4 Lasgun  
Powerpacks



4 Lasgun  
Powerpacks



4 Lasgun  
Powerpacks



1 Frag Grenade



1 Frag Grenade



1 Frag Grenade



1 Frag Grenade



1 Frag Grenade



1 Krak Grenade



1 Krak Grenade



1 Krak Grenade



1 Entrenching Tool



1 Entrenching Tool



1 Entrenching Tool



1 Entrenching Tool



1 Vox-caster



1 Entrenching Tool

## SQUAD EQUIPMENT

The Watchmaster is assisted by an appointed senior guardsman, usually the longest serving guardsman in the squad. This example shows a 'typical' issue of equipment, but extra ammunition, fragmentation grenades and krak grenades will be issued before attacks. Krak grenades are distributed throughout the squad on a random basis, depending on availability. Whilst the gunner carries most of the plasma gun's

photonic hydrogen fuel flasks, extra flasks are distributed amongst squad members. All squad members, except the plasma gunner, also carry a bayonet along with their small entrenching tool. Larger tools such as pick-axes and spades will be issued whilst a squad is assigned to 'labour' duties, ie, digging trenchworks.

This example is taken from the 143rd regiment, 8th company, 18th platoon, 1st squad.



Senior Guardsman  
(second-in-command)



Guardsman No.5



Guardsman No.6



Guardsman No.7



Guardsman No.8



Lasgun



Lasgun



Lasgun



Lasgun



Plasma Gun

4 Lasgun  
Powerpacks



4 Lasgun  
Powerpacks



4 Lasgun  
Powerpacks



4 Lasgun  
Powerpacks



2 Hydrogen  
Flasks



1 Frag Grenade



1 Frag Grenade



1 Frag Grenade



1 Frag Grenade



1 Frag Grenade



1 Krak Grenade



1 Krak Grenade



1 Hydrogen



1 Hydrogen



Flask

Flask



1 Entrenching Tool



1 Entrenching Tool



1 Entrenching Tool



1 Entrenching Tool

**ALTERNATIVE SPECIAL WEAPONS**

Each infantry squad will be issued with one of four special weapons for battlefield support.



Flamer



Grenade Launcher



Meltagun

# DEATH KORPS OF KRIEG HEAVY WEAPONS SQUAD



Senior Guardsman



Guardsman No.1



Guardsman No.2



Guardsman No.3



Heavy Bolter

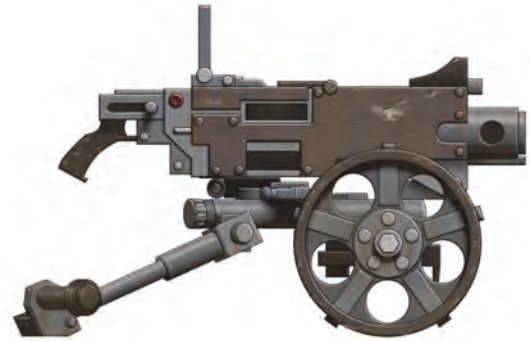

Heavy Bolter



Lasgun

Lasgun



Lasgun

Lasgun



2 Lasgun Powerpacks

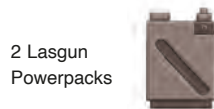

2 Lasgun Powerpacks



2 Lasgun Powerpacks



2 Lasgun Powerpacks



Heavy Bolter Ammo Box



Heavy Bolter Ammo Box



Heavy Bolter Ammo Box



Heavy Bolter Ammo Box



1 Entrenching Tool



1 Entrenching Tool



1 Entrenching Tool



1 Entrenching Tool

**SQUAD ORGANISATION AND EQUIPMENT**

Each squad consists of 6 men, split into three two-man teams of a gunner and loader. The squad is led by a senior guardsman, appointed by the platoon's officer. As well as the heavy weapon, each guardsman also carries a lasgun and extra ammunition, meaning they are heavily encumbered. A squad usually occupies a static position to provide fire support and avoid difficult and time consuming repositioning of the weapons. This example is taken from the heavy weapons platoon of the 143rd Siege regiment, 12th company.



Guardsman No.4



Guardsman No.5

**OTHER HEAVY WEAPONS**

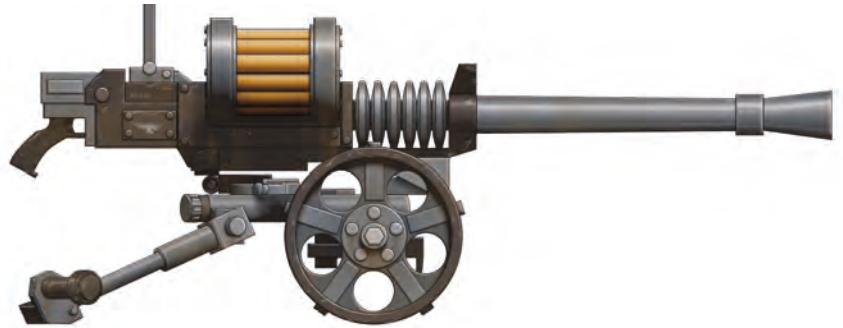

Autocannon



Heavy Bolter



Twin-Linked Heavy Stubbers



Lasgun

Lasgun

2 Lasgun

Powerpacks



2 Lasgun

Powerpacks



Heavy Bolter Ammo Box



Heavy Bolter Ammo Box



1 Entrenching Tool



1 Entrenching Tool

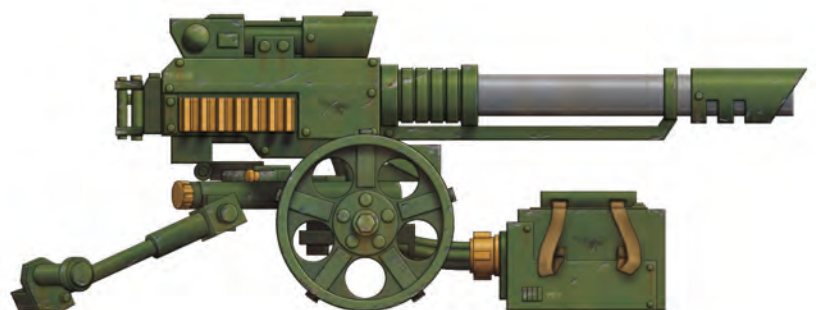

Lascannon



Mortar

# FIELD ARTILLERY COMPANY

## Company Headquarters



Company CO + Staff and Centaur



Trojan Communications Vehicle

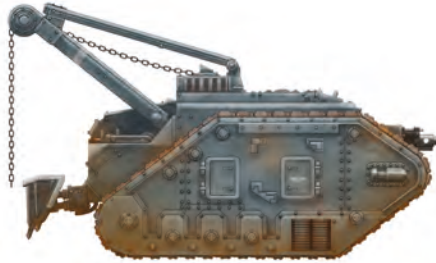

Atlas Engineering and Recovery Vehicle

## Supply Column

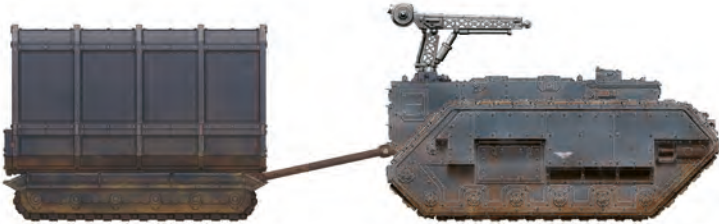

Trojan Ammunition Carrier and Trailer



Trojan Ammunition Carrier and Trailer



Trojan Ammunition Carrier and Trailer



Trojan Supplies Carrier and Trailer

## Battery 1



Battery HQ and Centaur



Battery HQ and Centaur



Heavy Mortar and Centaur Tractor



Heavy Mortar and Centaur Tractor



Heavy Mortar and Centaur Tractor



Heavy Mortar and Centaur Tractor

### Battery 2



Battery HQ and Centaur



Quad-Launcher and Centaur Tractor



Quad-Launcher and Centaur Tractor



Quad-Launcher and Centaur Tractor



Quad-Launcher and Centaur Tractor

### Battery 3



Battery HQ and Centaur



Quad-Launcher and Centaur Tractor



Quad-Launcher and Centaur Tractor



Quad-Launcher and Centaur Tractor



Quad-Launcher and Centaur Tractor

# DEATH KORPS OF KRIEG INFANTRY COMPANY

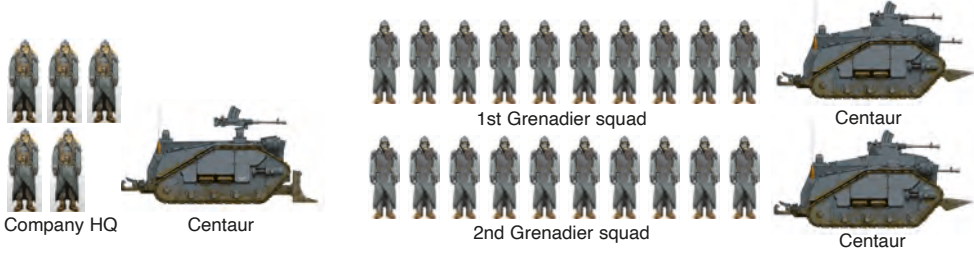

This is a theoretical organisation. The exact distribution of heavy weapons will vary. The heavy weapons platoon does not fight as a single unit but is deployed as single squads or ad-hoc groups of squads as needed, often under the direct command of the company headquarters. The number of grenadier squads available to a company will vary.

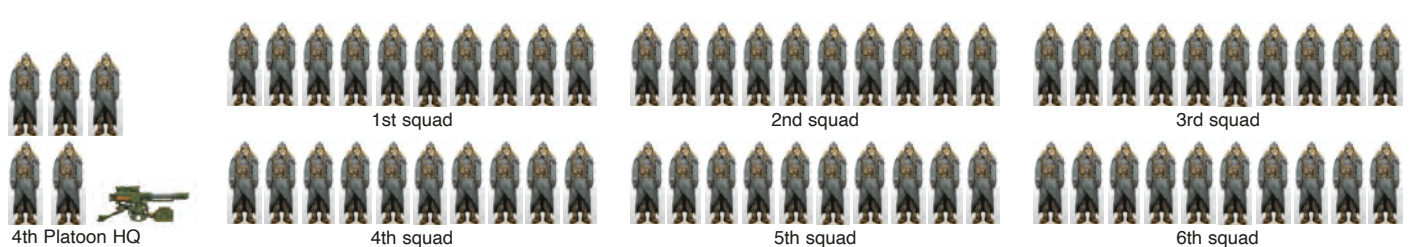

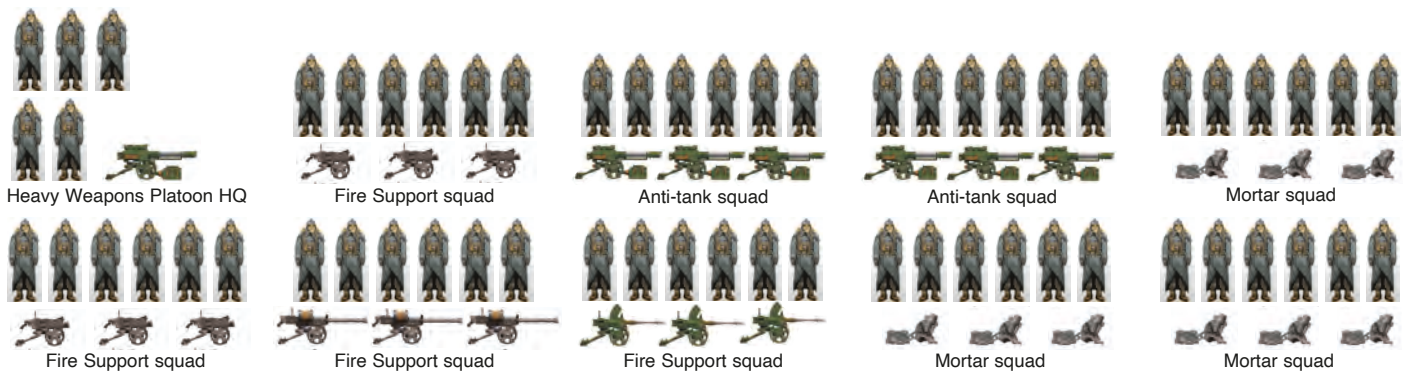

TO & E					
1	Captain	3	Centaur carriers	19	Flamers
11	Lieutenants	11	Mortars	19	Grenade launchers
75	Watchmasters	9	Lascannons	18	Plasma guns
653	Other ranks	8	Heavy bolters	18	Melta-guns
740	Men total	8	Heavy stubbers	18	Hellguns
		5	Autocannons	712	Lasguns
		2	Heavy flamers	32	Las pistols

# GORGON

## HEAVY ASSAULT TRANSPORT



The Gorgon is a huge, heavily armoured transport vehicle used to carry a large number of assault troops into enemy front lines, before disgorging them directly into enemy positions. Generally only deployed during trench warfare, where infantry must cross no-man's land, the Gorgon has a heavily armoured prow to protect it as it rumbles forwards. The vehicle is so large and cumbersome, and carries so many men, that on an open battlefield it is considered to be a large, slow target that draws too much enemy fire. Tactically, Gorgon assaults should only take place across a short distance, after the enemy has been well suppressed by a sustained artillery bombardment.

A Gorgon can carry a full platoon in its open-topped hold, albeit in very cramped conditions. Troops inside a Gorgon are generally only required to make the short journey across no-man's land before disembarking directly into the enemy's trenches, so even basic comforts are not required. As the Gorgon reaches its target, the armoured ramp drops and the men charge out, weapons blazing, to overrun the enemy positions by sheer weight of numbers.

The Gorgon is lightly armed, with heavy stubbers providing suppressing fire as the infantry disembark. Some Gorgons are fitted with additional sponsons to assist in this role, commonly these variants are equipped with multiple heavy bolters or mortars to lob shells into enemy trenches as the Gorgon approaches. Despite its size, the Gorgon does not carry any larger weaponry. This is because its role is not to destroy the enemy, but to deliver an infantry platoon safely in the face of heavy enemy fire.

As a specialist vehicle, the Gorgon is only deployed for carefully selected missions, such as attacking heavily fortified

enemy defences, or delivering troops into a breach during a siege. They are not routinely deployed for front line operations unless to assist a major offensive. Before the attack, the assaulting platoons are pre-loaded into the Gorgon whilst still in relative safety behind the frontlines, before rolling forwards. The Gorgon's long chassis means it can cross most trenches without hinderance.

For such a large vehicle, the Gorgon has a small crew of just three men, a driver and two gunners, who also have remote control over any sponson weapons. Gorgons can also be used as an assault landing craft as they are amphibious and can cross rivers with little difficulty.

As a specialised armoured vehicle, the Gorgon is not common amongst Imperial Guard regiments. It is mostly widely used by siege regiments for trench warfare, but they are sometimes issued to armoured regiments and infantry regiments when the demands of a campaign require, but its vulnerability on the open battlefield makes this the exception rather than the rule.

Vanaheim pattern Gorgon armed with mortars

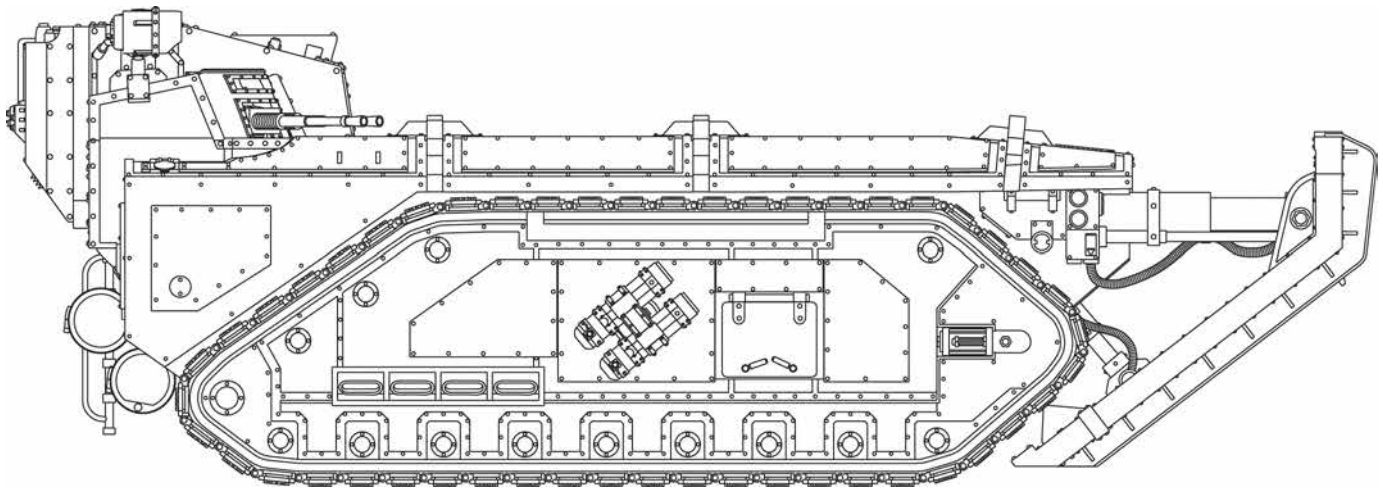

DVLA 6724930



**ADEPTUS MECHANICUS DEPARTMENTO MANUFACTURUM**

**TECHNICAL SPECIFICATIONS**



---

<p>Vehicle Designation 5657-776-0155-G099</p> <p>Vehicle Name <u>GORGON</u></p> <p>Forge World of Origin <u>VANAHEIM</u></p> <p>Known Patterns <u>I-VII</u></p> <p>Crew <u>DRIVER, 2 X GUNNERS</u></p> <p>Powerplant <u>XD503 V12 P6 TWIN-COUPLED MULTI-FUEL</u></p> <p>Weight <u>220 TONNES</u></p> <p>Length <u>13.9M</u></p> <p>Width <u>8.1M</u></p> <p>Height <u>4.9M</u></p> <p>Ground Clearance <u>.74M</u></p> <p>Max Speed - On Road <u>27 KPH</u></p> <p>Max Speed - Off Road <u>19 KPH</u></p>	<p>Main Armament <u>4 X HEAVY STUBBERS</u></p> <p>Secondary Armament <u>4 X MORTARS</u></p> <p>Traverse <u>92°</u></p> <p>Elevation <u>-22° TO +34°</u></p> <p>Main Ammunition <u>8,000 ROUNDS</u></p> <p>Secondary Ammunition <u>4 ROUNDS</u></p> <p>Armour</p> <p style="padding-left: 20px;">Turret <u>NA</u></p> <p style="padding-left: 20px;">Superstructure <u>200 MM</u></p> <p style="padding-left: 20px;">Hull <u>180 MM</u></p> <p style="padding-left: 20px;">Gun Mantlet <u>NA</u></p>
---	---

Date 1887345.M40

signature *Frank Wright*

Magos Fabricator

Dominus Ex Machina

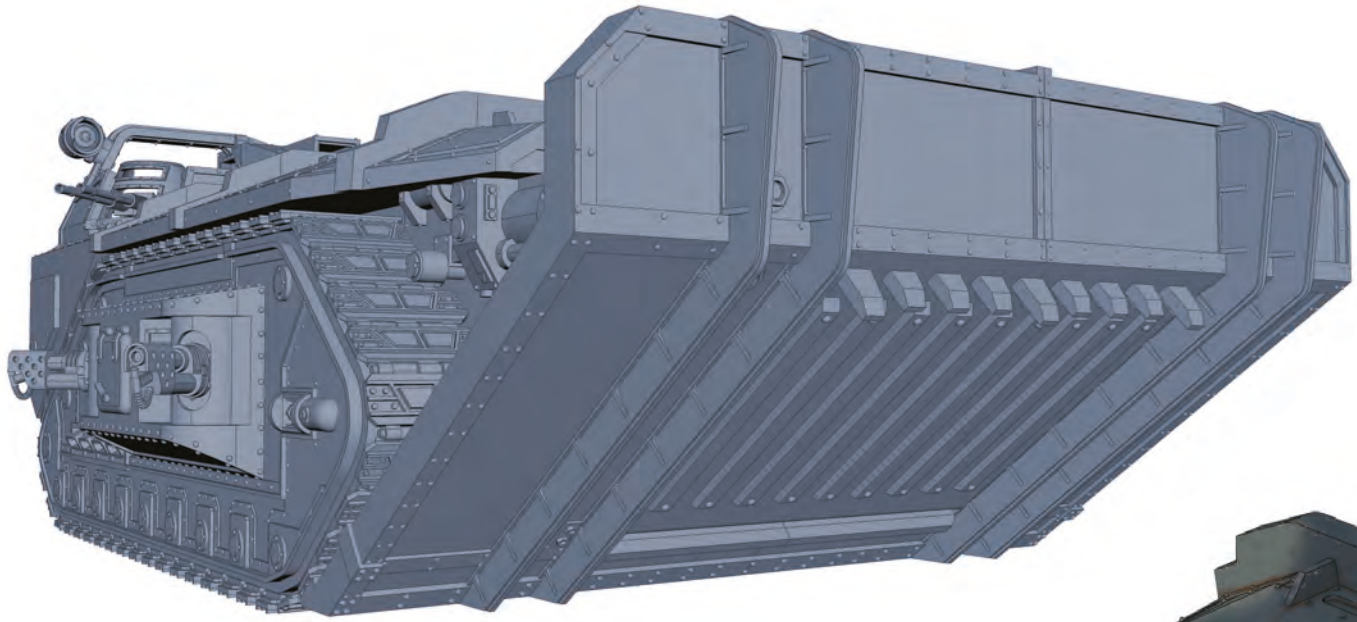

**GORGON**  
**HEAVY ASSAULT TRANSPORT**  
Interior Details

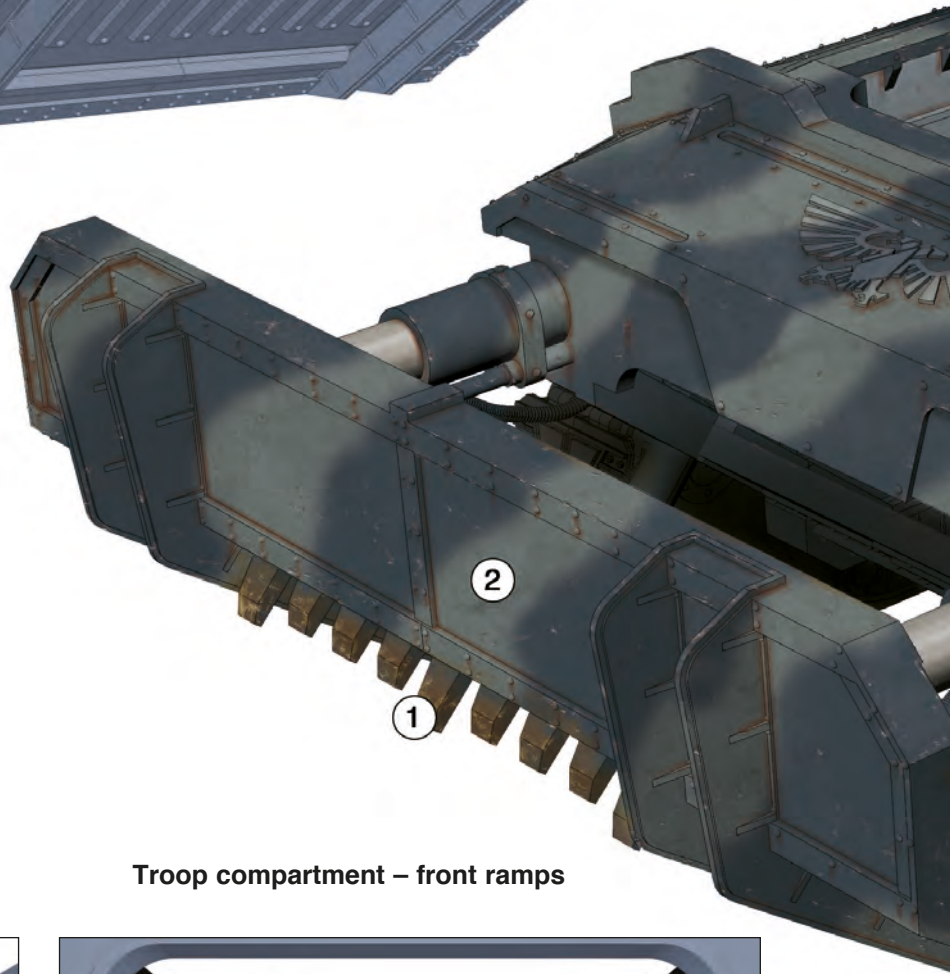

Troop compartment – rear door

Troop compartment – front ramps

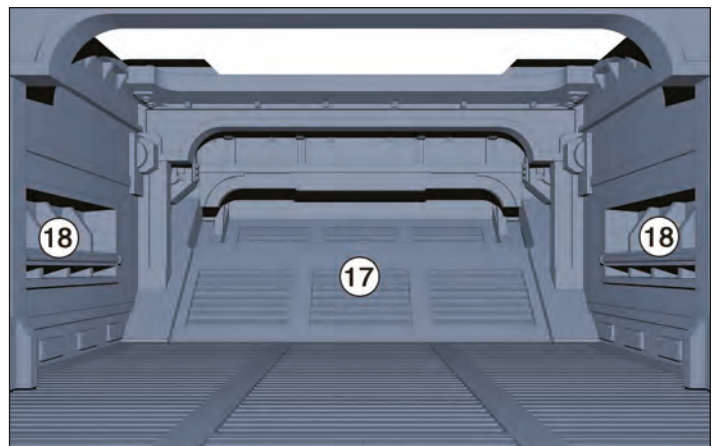
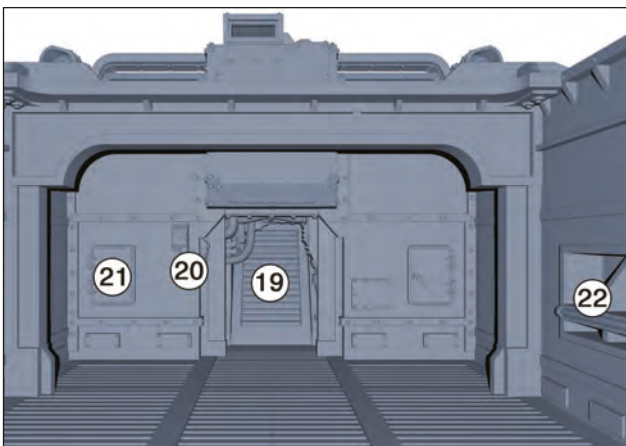



**Key**

1. Front ramp teeth.
2. Armoured dozerblade.
3. Ramp pneumatic piston.
4. Ramp support.
5. Track tensioning screw.
6. Reinforced armour plate.
7. Troop compartment.
8. Bracing girder.
9. Forward remote control sponson with Heavy Flamer.
10. Loading hatch.
11. Rear remote control sponson.
12. Twin Heavy Stubber turret.
13. Armoured shield.
14. Driver's periscope.
15. Searchlight rail.
16. Searchlight.
17. Interior ramp/drawbridge.
18. Forward stowage bins.
19. Rear Ramp.
20. Emergency ramp control panel.
21. Maintenance access hatch.
22. Rear stowage bins.

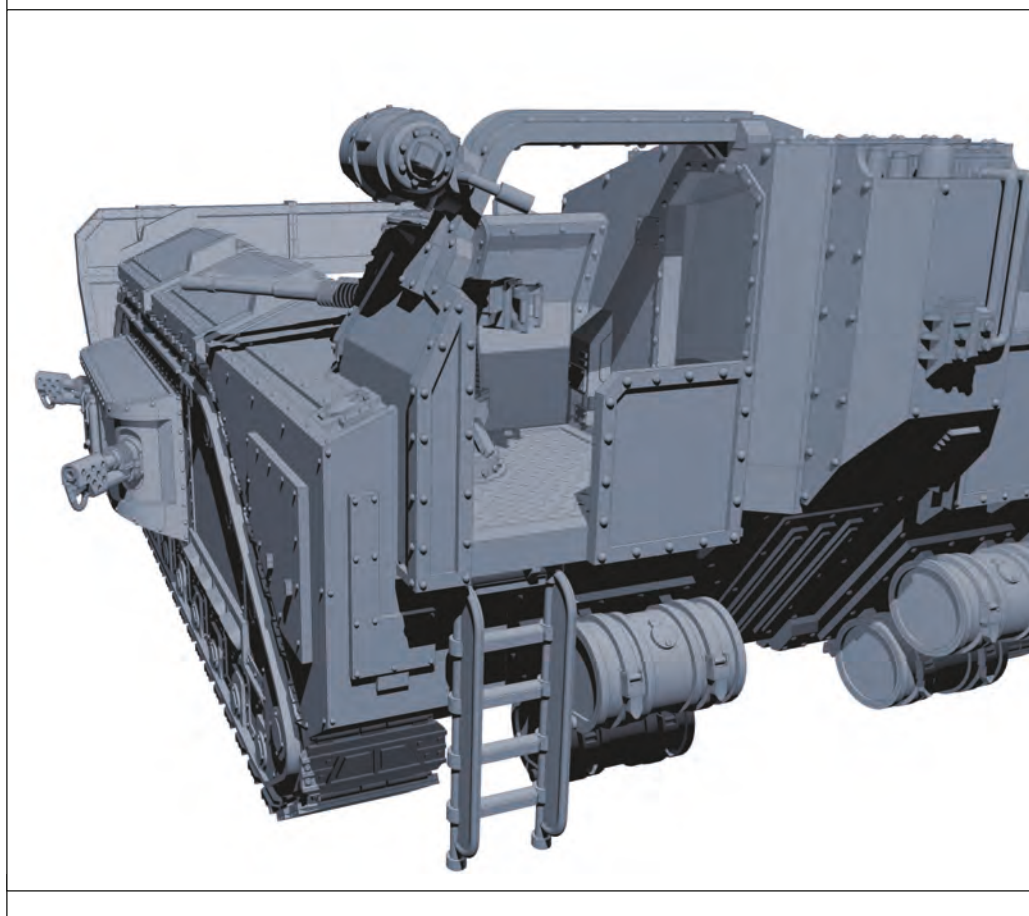
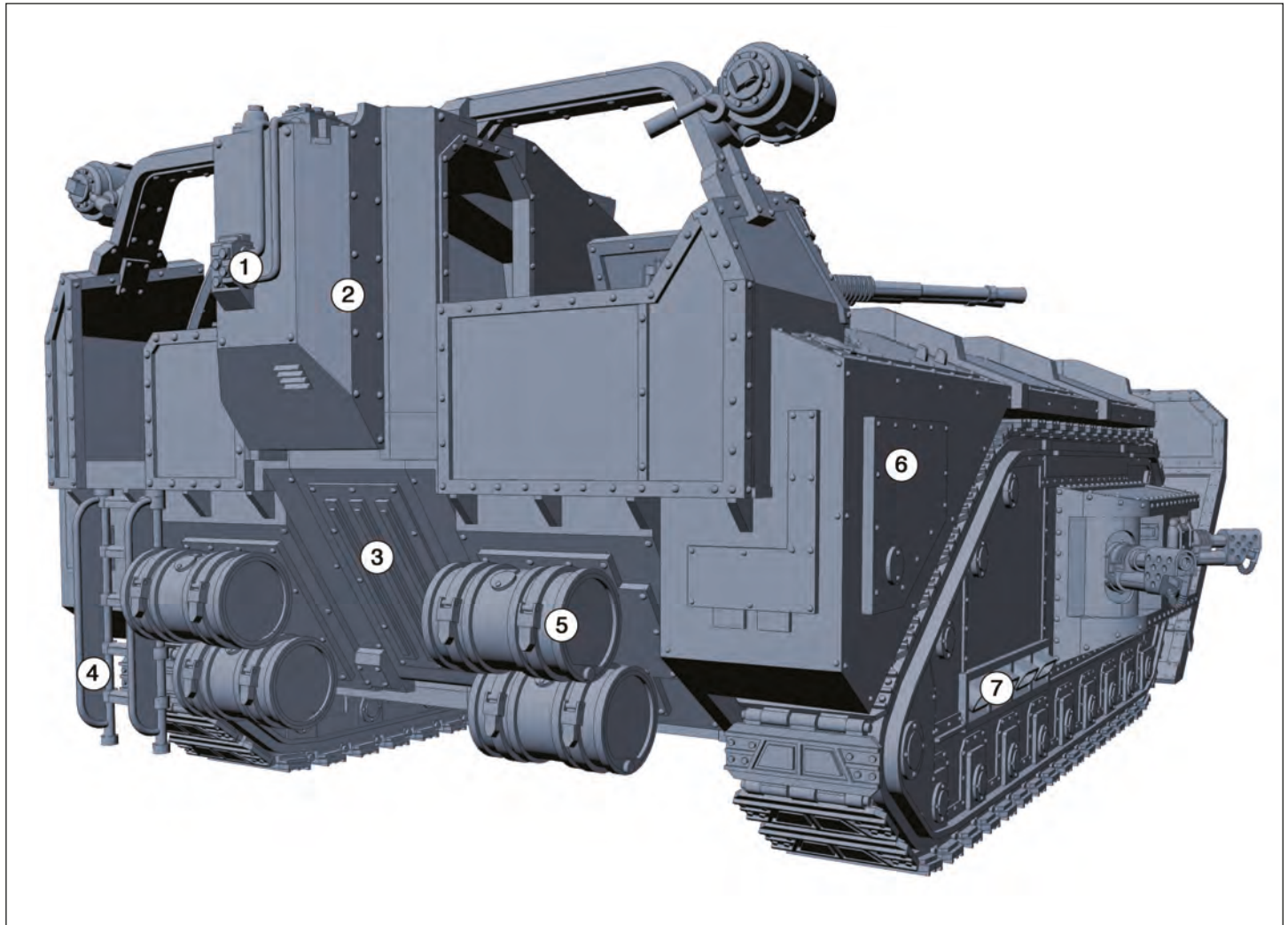

**KEY**

1. Electronics maintenance panel.
2. Communications, sensors and navigation systems.
3. Rear access door.
4. Crew ladder.
5. Auxiliary fuel drums.
6. Internal fuel tanks and heavy stubber ammunition store.
7. Engine exhausts.

Gorgon armed with heavy flamers

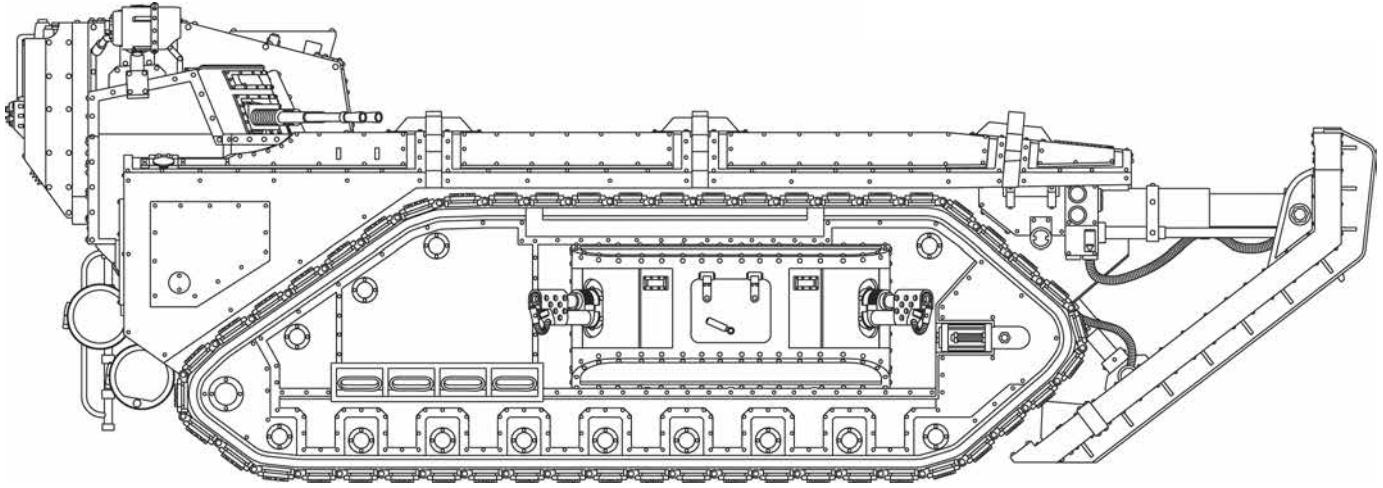

Gorgon, plan view

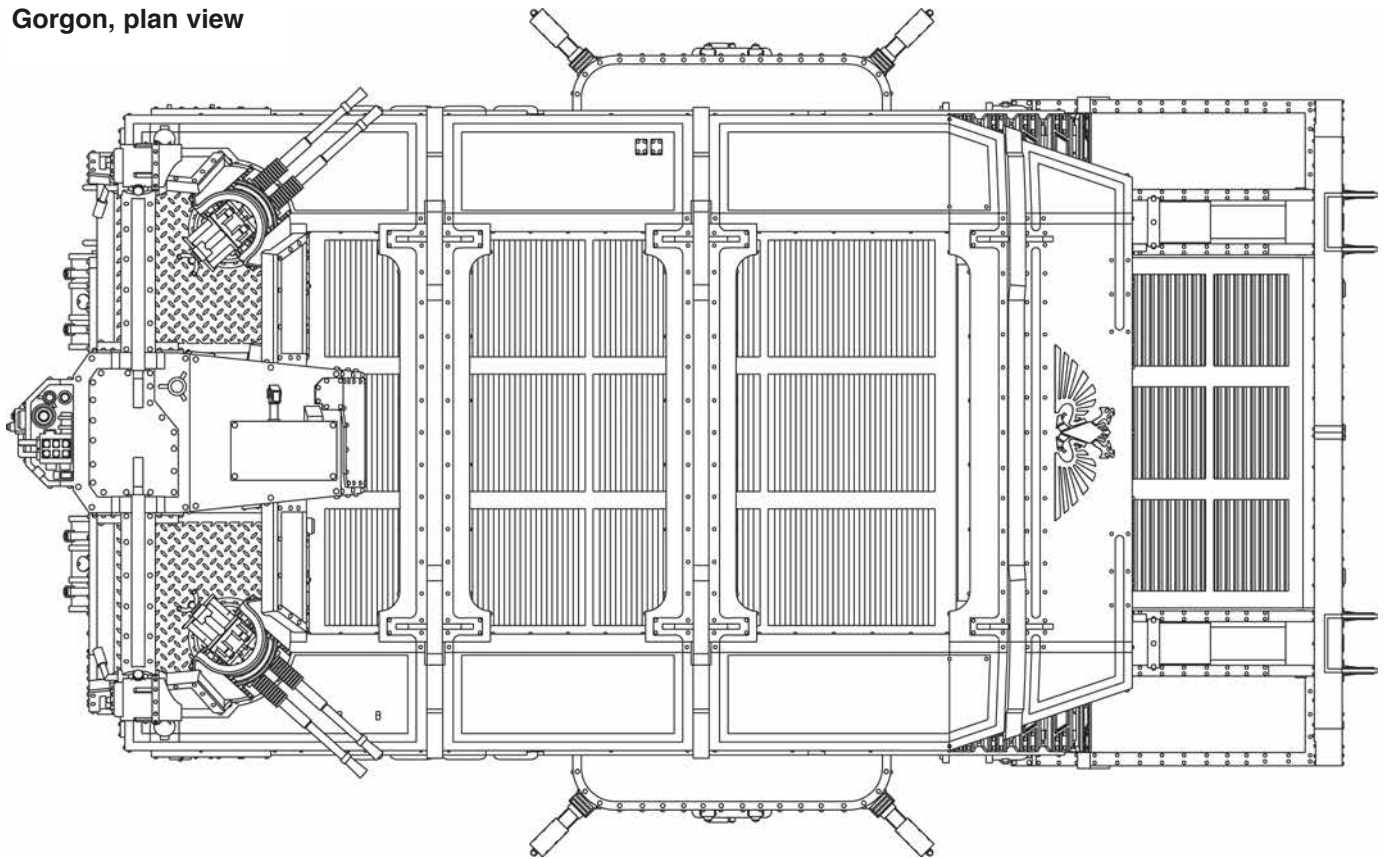

Gorgon, front view

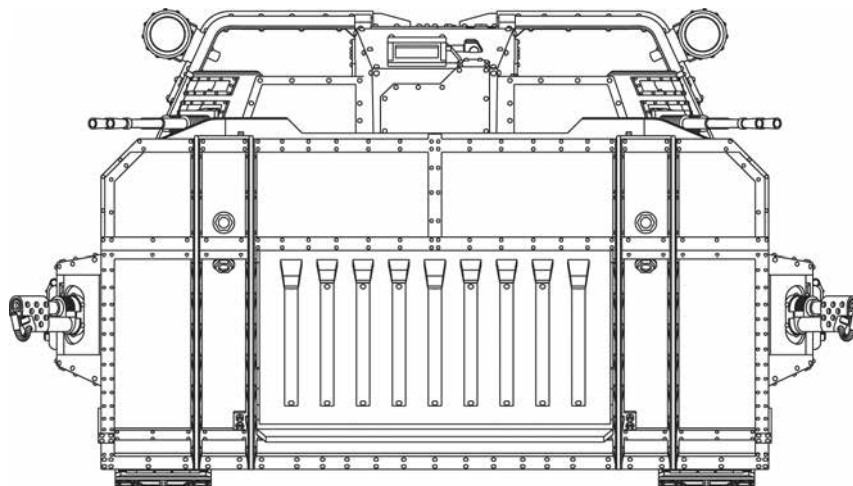

# CENTAUR



The Centaur is a small utility vehicle, used in a wide variety of roles – as a command squad transport, communications vehicle, supply vehicle towing trailers, but most commonly as an artillery tow for field artillery guns and a transport for the gun's crew. The Centaur is not a frontline combat vehicle, although it does have limited armour protection against enemy shelling.

The Centaur has two crew as standard, a driver and a gunner, although many vehicles operate with just a single driver and rely on the passengers to man the gun. In addition to the crew, the Centaur can cram in up to five passengers.

The Centaur is usually armed with a single pintle-mounted heavy stubber. This weapon is often dismounted and used by the infantry for additional fire support, but most artillery crews retain the weapon as their best defence against a surprise enemy attack, especially as field artillery are usually required to operate close to the front. A feature of the Centaur is its second weapons mount. Positioned in the forward hull next to the driver, a squad in transit can attach their special or heavy weapon here and continue to use it to protect the vehicle. Most artillery crews are not issued a weapon to mount here, but command squads and grenadier squads in transit find this feature useful.

As well as its weaponry, Centaurs are often upgraded with a variety of other useful features, such as dozerblades, smoke launchers, hunter-killer missiles and mine sweepers, which all

add to the vehicle's versatility on the battlefield.

The Centaur's main feature is its twin engines, mounted in the track sponsons. For its size, the Centaur has a very powerful power pack, useful for towing very heavy loads, but when freed from this role the Centaur's engine means it can reach a top speed of 110 kph on road and 70 kph off road. This speed means it is well-liked by its crew, who rely on its speed to avoid enemy fire.

Centaurs are often issued to grenadier units as a battlefield transport, to get them close to their targets quickly. Because these Centaurs are deployed into the heart of a battle, and must face enemy fire in no-man's land, the grenadiers' Centaur has been adapted with additional armour plates. This armour gives the driver and passengers some extra protection, especially against shrapnel. They are also fitted with a spiked-ram for breaking through razorwire obstacles.

On Vraks, the Krieg regiments deployed thousands of Centaurs, used in every imaginable role. Behind the trench lines, Centaurs were a common sight, racing along towing trailers of ammunition or bringing forward reinforcements.

Vanaheim pattern Centaur

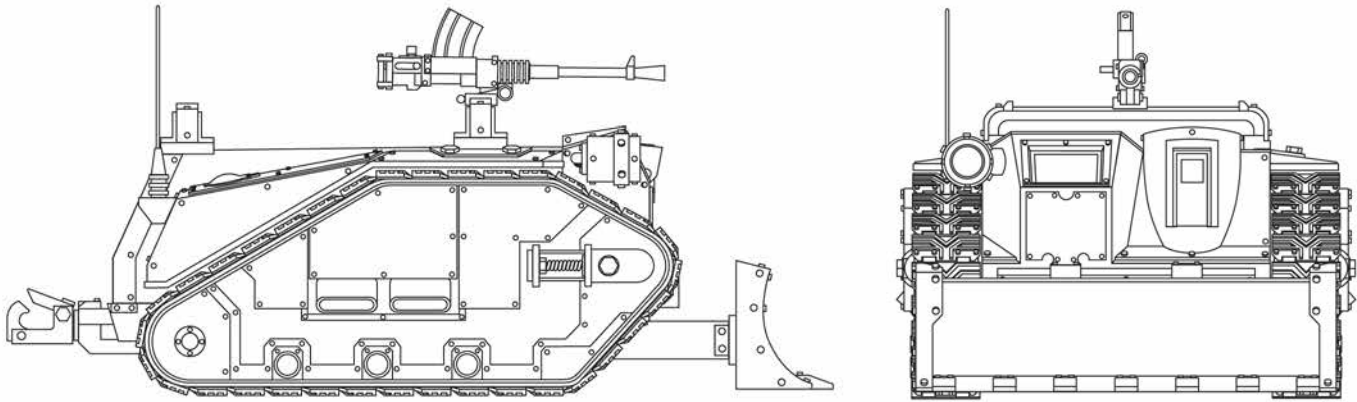

DVLA 6724930



**ADEPTUS MECHANICUS DEPARTMENTO MANUFACTURUM**

**TECHNICAL SPECIFICATIONS**



<p>Vehicle Designation 5657-436-0671-CN71</p> <p>Vehicle Name.....CENTAUR.....</p> <p>Forge World of Origin.....VANAHEIM.....</p> <p>Known Patterns.....II-XIV.....</p> <p>Crew.....DRIVER, GUNNER.....</p> <p>Powerplant.....VULCANOR 8 TWIN-COUPLED MULTI-FUEL.....</p> <p>Weight.....6.2 TONNES.....</p> <p>Length.....4.1M.....</p> <p>Width.....3M.....</p> <p>Height.....2.3M.....</p> <p>Ground Clearance......4M.....</p> <p>Max Speed = On Road.....110 KPH.....</p> <p>Max Speed = Off Road.....70 KPH.....</p>	<p>Main Armament.....HEAVY STUBBER.....</p> <p>Secondary Armament.....NA.....</p> <p>Traverse.....160°.....</p> <p>Elevation.....-22° TO +15°.....</p> <p>Main Ammunition.....300 ROUNDS.....</p> <p>Secondary Ammunition.....NA.....</p> <p>Armour.....</p> <p style="padding-left: 20px;">Turret.....NA.....</p> <p style="padding-left: 20px;">Superstructure.....80 MM.....</p> <p style="padding-left: 20px;">Hull.....50 MM.....</p> <p style="padding-left: 20px;">Gun Mantlet.....NA.....</p> <p style="text-align: right;">Date.....1887345.M40.....</p> <p style="text-align: right;">signature.....<i>Frank</i>.....</p> <p style="text-align: right;">Magos Fabricator</p>
---	--

Dominus Ex Machina

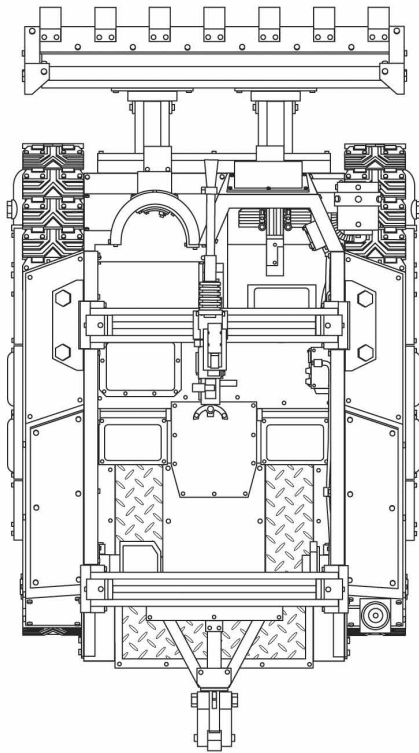

Vanaheim pattern Centaur – grenadier variant

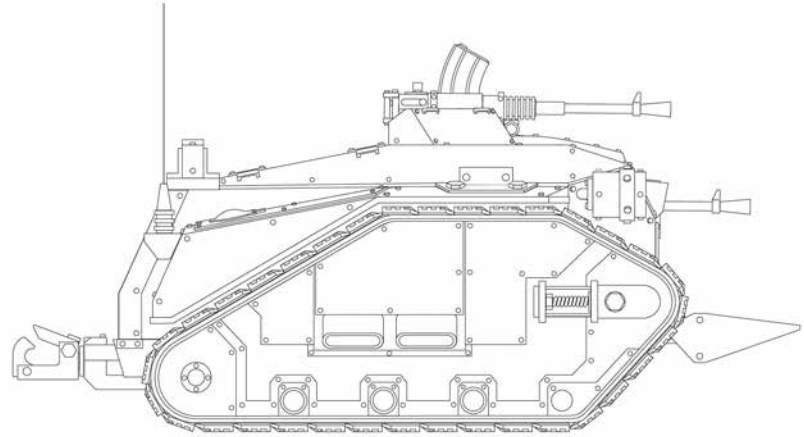

**CENTAUR..... 40 POINTS PER MODEL**

	BS	Armour		
		Front	Side	Rear
Centaur	3	11	10	10

**Unit Composition:**

- 1 Centaur

**Unit Type:**

- Vehicle (tank, open topped, fast)

**Wargear:**

- Pintle mounted Heavy Stubber

**Special Rules:**

- Hull Weapon Mount
- Artillery Tractor

**Transport Capacity**

- 5 models

**OPTIONS:**

- May take any of the following:
  - Searchlight.....1 point per model
  - Smoke launchers.....5 points per model
  - Dozerblade .....10 points per model
  - Extra armour .....15 points per model
  - Camo netting.....20 points per model

**Hull Weapon Mount**

A Centaur may hull mount a special or heavy weapon carried by a transported squad member. This weapon is crewed by a passenger.

**Artillery Tractor**

When used as a tractor to tow an artillery piece, the Centaur is no longer a fast vehicle. It moves as a normal vehicle when towing a gun.

The towed guns are deployed and hitched-up to the Centaur in exactly the same manner as infantry embarking or disembarking from the vehicle

**Dedicated Transport:** A Centaur is a dedicated transport option for a Company Command Squad, Platoon Command squad and a Storm Troopers squad in an Imperial Guard codex army. The squad must be 5 model or less.

# FIELD ARTILLERY HEAVY QUAD-LAUNCHER AND HEAVY MORTAR



The term 'field artillery' covers various smaller artillery pieces which are generally deployed closer to the front line and used in direct support of the infantry, rather than the heavy artillery which is deployed far to the rear and used for sustained bombardments and harrassing fire deep into enemy lines. Field artillery is more mobile and can be quickly hitched to a towing Centaur and pulled forward behind the infantry to rapidly set up again and engage an enemy counter attack.

For Krieg siege regiments, the two most common field artillery pieces are heavy quad-launchers and heavy mortars. Both form part of the field artillery companies, and are generally deployed in batteries of up to four guns, each with its own tow, and supported by various command vehicles and extra ammunition vehicles and trailers.

Quad launchers, also commonly known as 'quad' or 'thudd' guns, due to their distinctive sound when firing, are effectively four large mortars mounted on a single carriage. Once the 'quads' were common weapons amongst the Imperial Guard, but most of these weapons have now been relegated to second line units, used to arm planetary defence forces and militia units. The quad-launcher's main drawback is the time required to reload between volleys. Ammunition is placed into the hop, the breech is then hand cranked back which allows the round to feed into the breech, which then slams forwards into the ready position. The hop can then be reloaded with another shell. When the gun fires, the recoil allows the second shell to

load automatically. Once this second shell is fired, the whole slow loading process must be repeated. The weapons complex automated loader is also prone to jamming and misfeeds and must be carefully maintained in the field. Despite these drawbacks, when loaded the quad-launcher is a highly effective anti-infantry and suppression weapon, lobbing four shells at a time in a high trajectory to rain down onto enemy trenches in a distinctive rapid bursting four shell pattern. The 'quads' are also deployed for point defence, where they are used in a direct fire role against enemy infantry attacks. The weapon lacks the range of heavier artillery and as such is of little use for box-barrages or counter-battery fire.

The field artillery company's other weapon is the heavy mortar, which is a larger version of the standard infantry mortar, firing a larger, heavier shell. This is the same weapon that is commonly mounted on the Griffon mortar carrier, but mounted on a wheeled carriage and towed by a Centaur or Trojan. The mortar is breech loading, and a well-drilled crew can maintain a good steady rate of fire for several hours. The heavy mortar is highly versatile, and unlike the quad-launcher it can fire a wide variety of ammunition. The heavy mortar is often used to fire illumination shells at night, or to lay smoke barrages before an infantry attack. Whilst lacking the destructive power of the 'quads', the heavy mortar's versatility makes it popular with artillery commanders.

Lucius pattern quad-launcher

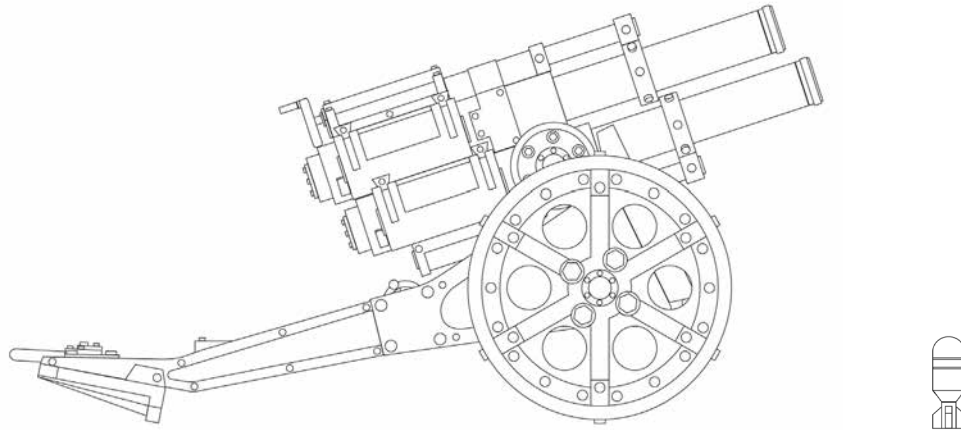

DVLA 6724930



**ADEPTUS MECHANICUS DEPARTMENTO MANUFACTURUM**

**TECHNICAL SPECIFICATIONS**



<p>Vehicle Designation 2312-673-7609-HQL3</p> <p>Vehicle Name QUAD LAUNCHER</p> <p>Forge World of Origin LUCIUS</p> <p>Known Patterns II-LX</p> <p>Crew 4 X GUNNERS</p> <p>Powerplant NA</p> <p>Weight 3.8 TONNES</p> <p>Length 4.6M</p> <p>Width 2.3M</p> <p>Height 2.2M</p> <p>Ground Clearance 44M</p> <p>Max Speed = On Road NA</p> <p>Max Speed = Off Road NA</p>	<p>Main Armament 4 X MORTARS</p> <p>Secondary Armament NA</p> <p>Traverse 0°</p> <p>Elevation +10° TO +45°</p> <p>Main Ammunition NA</p> <p>Secondary Ammunition NA</p> <p>Armour</p> <p>Surret NA</p> <p>Superstructure NA</p> <p>Hull NA</p> <p>Gun Mantlet 30 MM</p>
--	---

Date 1556092.1438

signature *Jack K...*

Magos Fabricator

Dominus Ex Machina

Lucius pattern Heavy Mortar

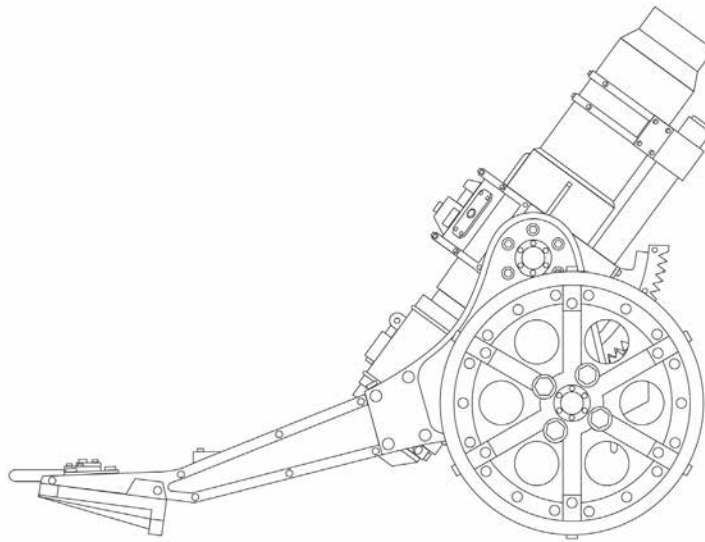

ADEPTUS MECHANICUS DEPARTAMENTO MANUFACTURUM TECHNICAL SPECIFICATIONS	
Vehicle Designation 7556-307-9857-HM03	Main Armament HEAVY MORTAR
Vehicle Name HEAVY MORTAR	Secondary Armament NA
Forge World of Origin LUCIUS	Traverse 0°
Known Patterns I-XII	Elevation +20° TO +82°
Crew 4 X GUNNERS	Main Ammunition NA
Powerplant NONE	Secondary Ammunition NA
Weight 3.5 TONNES	Armour
Length 4.6M	Surret NA
Width 2.3M	Superstructure NA
Height 3.3M	Hull NA
Ground Clearance .6M	Gun Mantlet NA
Max Speed = On Road NA	
Max Speed = Off Road NA	
	Date 1556092.M38
	signature <i>Jack Wood</i>
	Magos Fabricator

Dominus Ex Machina

# HEAVY ARTILLERY EARTHSHAKER AND MEDUSA



As well as the field artillery companies, the backbone of a siege regiment's artillery are the heavy artillery companies. These are the big guns, deployed well back from the front line for sustained bombardment of enemy lines. Heavy artillery includes the workhorse Earthshaker cannon, and the aging Medusa heavy siege guns. They fire sustained bombardments, box barrages to isolate a battlefield from enemy reinforcements, harassing fire, counter-battery fire to suppress enemy artillery and destructive fire at selected targets, all spotted for by officers on the front line.

The Earthshaker is the Imperial Guard's standard artillery piece. It is a 132mm calibre weapon, capable of firing a 38 kg shell over 15 kms at a velocity of 814 mps. So a shell fired to maximum range would take 19 seconds from firing to impacting. The cannon itself is the model of reliability and consistency. It uses its standard five powder charges, but this can be increased with the addition of charges six and seven. This will increase the range at the risk of extra wear and stress on the gun itself. Firing higher charge shots induces considerable strain and erosion on the barrel and the firing chamber, so that the breach seal fails, drastically reducing the gun's range and velocity and increasing the risk of a misfire. Because of this, the use of higher charges must be authorised by higher command, and the firing is recorded on each gun. No gun may fire more than twenty overcharged rounds.

The Earthshaker can also fire different shells as required: smoke shells, incendiary shells, illumination shells and

diamantine-tipped armour penetrating rounds are all part of the Earthshaker's armoury.

The Medusa siege gun is a very different weapon. It fires a heavier shell at a lower velocity over a shorter distance. The heavy shell has excellent destructive capabilities, but the Medusa cannot match the Earthshaker for range, and as such is less useful for harassing fire and counter-battery fire, instead it is mainly used to destroy enemy bunkers, pillboxes, walls and trenches.

Both the heavy artillery guns are too large to be towed by a Centaur, and the larger Trojan is needed. The Trojan can also carry some ammunition and the crew.

Siege Regiments are not only supported by their own artillery companies, but also by the army's bombardment corps. These are concentrations of heavy artillery pieces that back up the attacking regiments, and are used to keep-up sustained bombardments and add to the artillery's concentration of shells before major offensives.

Lucius pattern Earthshaker cannon

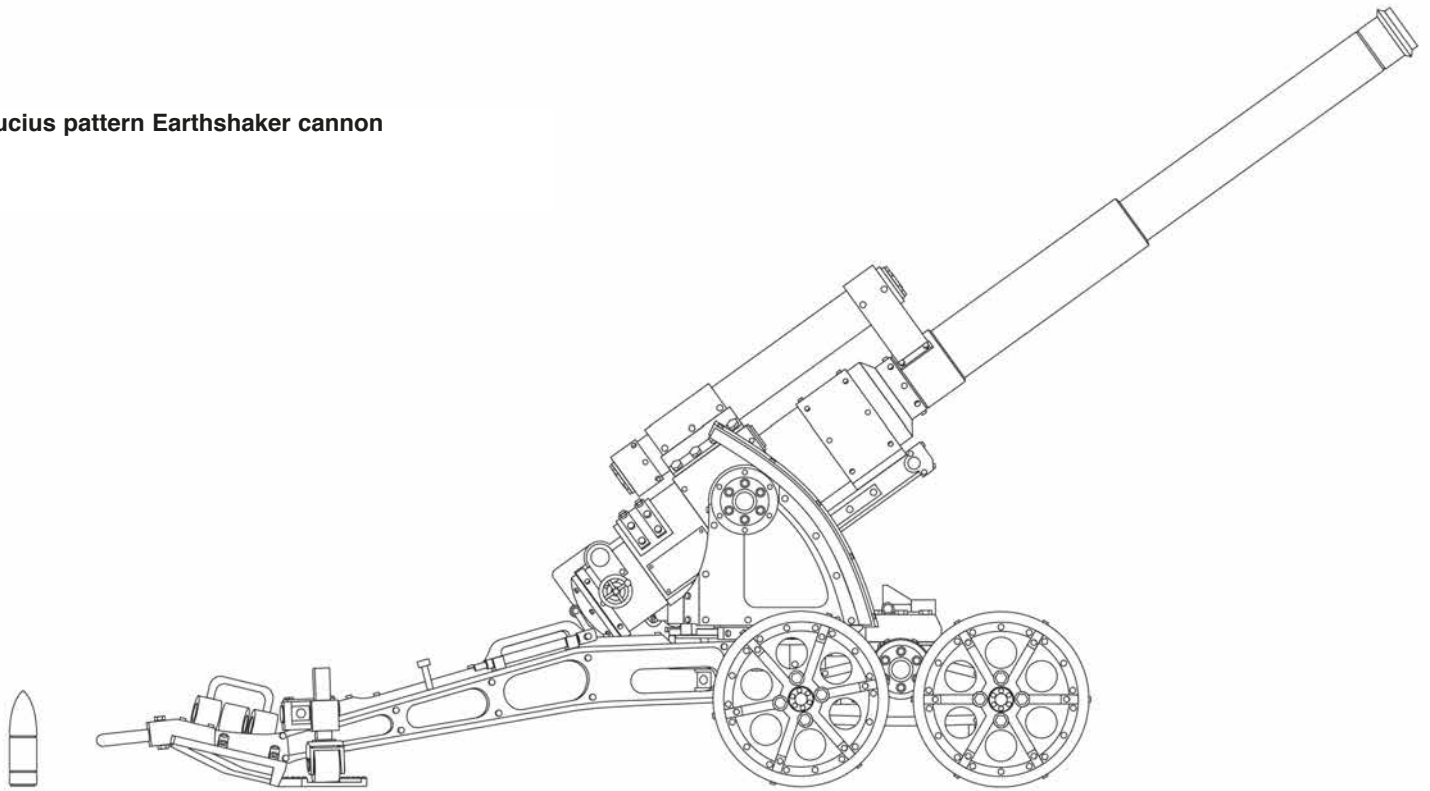



**ADEPTUS MECHANICUS DEPARTMENTO MANUFACTURUM**

**TECHNICAL SPECIFICATIONS**



<p>Vehicle Designation 3284-332-8751-EC65</p> <p>Vehicle Name <u>EARTHSHAKER CANNON</u></p> <p>Forge World of Origin <u>LUCIUS</u></p> <p>Known Patterns <u>I-V</u></p> <p>Crew <u>6 X GUNNERS</u></p> <p>Powerplant <u>NONE</u></p> <p>Weight <u>14 TONNES</u></p> <p>Length <u>8.2M (CARRIAGE ONLY)</u></p> <p>Width <u>3.7M</u></p> <p>Height <u>4.2M (GUN AT 0° ELEVATION)</u></p> <p>Ground Clearance <u>.7M</u></p> <p>Max Speed = On Road <u>NA</u></p> <p>Max Speed = Off Road <u>NA</u></p>	<p>Main Armament <u>EARTHSHAKER</u></p> <p>Secondary Armament <u>NA</u></p> <p>Traverse <u>0°</u></p> <p>Elevation <u>+0° TO +68°</u></p> <p>Main Ammunition <u>NA</u></p> <p>Secondary Ammunition <u>NA</u></p> <p>Armour</p> <p>Surret <u>NA</u></p> <p>Superstructure <u>NA</u></p> <p>Hull <u>NA</u></p> <p>Gun Mantlet <u>60MM</u></p>
--	---

Date 1754979.1439

signature 

Magos Fabricator

Dominus Ex Machina

Lucius pattern Medusa siege gun

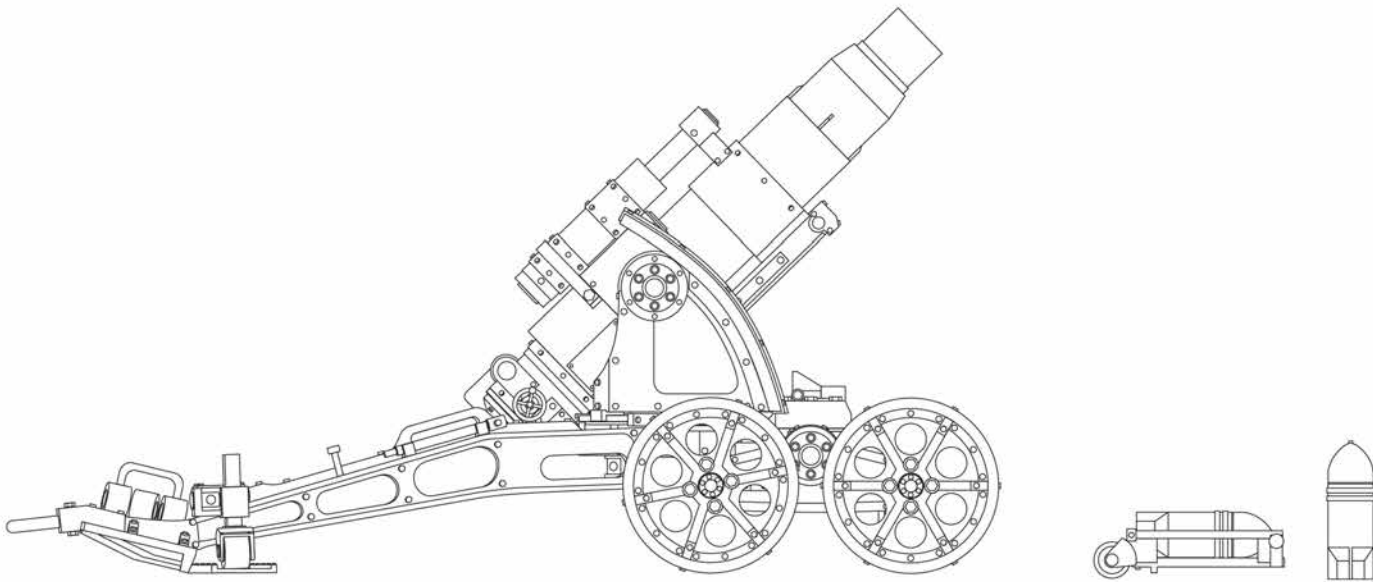

DVL/A6724960

**ADEPTUS MECHANICUS DEPARTAMENTO MANUFACTURUM  
TECHNICAL SPECIFICATIONS**

Vehicle Designation 0198-561-6730-MGL2	Main Armament MEDUSA SIEGE GUN
Vehicle Name MEDUSA SIEGE GUN	Secondary Armament NA
Forge World of Origin LUCIUS	Traverse 0°
Known Patterns I-III	Elevation +0° TO +54°
Crew 6 X GUNNERS	Main Ammunition NA
Powerplant NONE	Secondary Ammunition NA
Weight 12 TONNES	Armour
Length 8.2M (CARRIAGE ONLY)	Surret NA
Width 3.7M	Superstructure NA
Height 3.7M (GUN AT 0° ELEVATION)	Hull NA
Ground Clearance .7M	Gun Mantlet 60MM
Max Speed - On Road NA	
Max Speed - Off Road NA	

Date 198804.M39

signature *Frank West*  
Magos Fabricator

Dominus Ex Machina

# LEMAN RUSS VARIANTS



Krieg siege regiments rely on massed infantry assaults, supported by heavy artillery barrages to grind their enemies down – despite their preferred tactics, Krieg’s regiments do not ignore the value of heavily armoured vehicles. Although siege regiments do not deploy tanks en masse, as entire companies operating together, they do use tanks to support their infantry attacks. Individual tanks companies and squadrons will be split up and attached to infantry platoons, and will be designated to accompany that platoon as they advance across no man’s land. The tank’s hull helps provides some cover for the infantry, as well as being able to quickly engage and destroy enemy heavy weapons with the tank’s main armament.

In this role the Krieg regiments use many Leman Russ variants; Vanquishers, Executioners, Exterminators, as well as siege tanks like the Demolisher and Thunderer, even Destroyer tank hunters when available, can all be deployed during an attack. Many Imperial Guard commanders regard Krieg’s uses of tanks as unsophisticated and backwards, resulting in unacceptably high loss rates. Krieg commanders regard the expenditure of armoured vehicles with the same callous disregard as that of men, they will simply find more tanks to replace losses.

Krieg tanks invariably have to cross no-man’s land, and the cratered and churned up ground is very difficult going, not to mention covered with enemy tank traps, anti-tank ditches and minefields. Krieg regiments usually equip their tanks with

additional help to cross this ground, like dozerblades or, more commonly, trench rails. These devices are fixed to the rear of the tank and help support the vehicle’s weight as it crosses a trench, preventing it from tipping backwards and becoming stranded. Minesweeper attachments are also widely used.

Because of the environment Krieg regiments are often deployed to fight in, the engines of their Leman Russes are also modified with additional filters for the engine and crew compartment, to prevent the exterior atmosphere affecting the tank’s inner workings. Krieg tanks are often seen with additional oxygen tanks and bottles of chemical cleaners added to the exterior.

One uncommon Leman Russ variant used by Krieg regiments is the Annihilator. The Annihilator takes its name from the more common Space Marine Predator variant. Like its namesake, the Leman Russ Annihilator variant replaces the tank’s main battle cannon with twin-linked lascannons. This requires the addition of extra powercells inside the tank, but these use the space saved by no longer storing the battle cannon’s ammunition. Its twin lascannons turn it into a tank-hunter, and in it is in this role that the tank excels. Of course such sophisticated tactical planning is not regarded as important by Krieg and so, where other regiments would regard the tank hunter as a defensive weapon, Krieg still throws them into the attack across no-man’s land.

Mars-Alpha pattern Leman Russ Annihilator with additional engine filters and trench rails

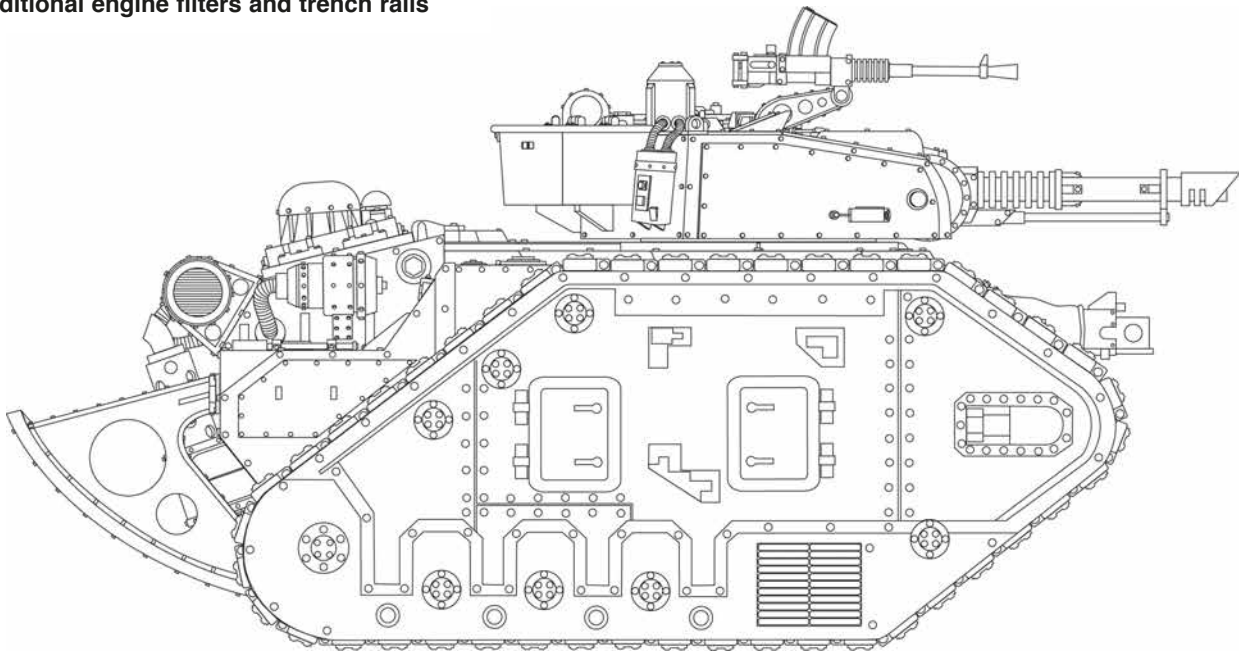

DVLA 6724930



**ADEPTUS MECHANICUS DEPARTMENTO MANUFACTURUM**

**TECHNICAL SPECIFICATIONS**



---

<p>Vehicle Designation 0198-561-6730-MG42</p> <p>Vehicle Name... LEMAN RUSS ANNIHILATOR</p> <p>Forge World of Origin... MARS</p> <p>Known Patterns... II-VI</p> <p>Crew... COMMANDER, DRIVER, GUNNER, LOADER, 2x SPONSON GUNNERS</p> <p>Powerplant... HL230 V12 MULTI-FUEL</p> <p>Weight... 58 TONNES</p> <p>Length... 7.08 M</p> <p>Width... 4.86 M</p> <p>Height... 4.42 M</p> <p>Ground Clearance... 15 M</p> <p>Max Speed = On Road... 40 KPH</p> <p>Max Speed = Off Road... 24 KPH</p>	<p>Main Armament... 2 X LASCANNONS</p> <p>Secondary Armament... LASCANNON OR HEAVY BOLTER</p> <p>Traverse... 360°</p> <p>Elevation... -8° TO +26°</p> <p>Main Ammunition... UNLIMITED</p> <p>Secondary Ammunition... UNLIMITED OR 600 ROUNDS</p> <p>Armour</p> <p style="margin-left: 20px;">Turret... 200 MM</p> <p style="margin-left: 20px;">Superstructure... 180 MM</p> <p style="margin-left: 20px;">Hull... 150 MM</p> <p style="margin-left: 20px;">Gun Mantlet... 100 MM</p>
---	---

Date... 1822015 M38

signature... *Frankroyl*

Magos Fabricator

Dominus Ex Machina

**Phaeton pattern Leman Russ**

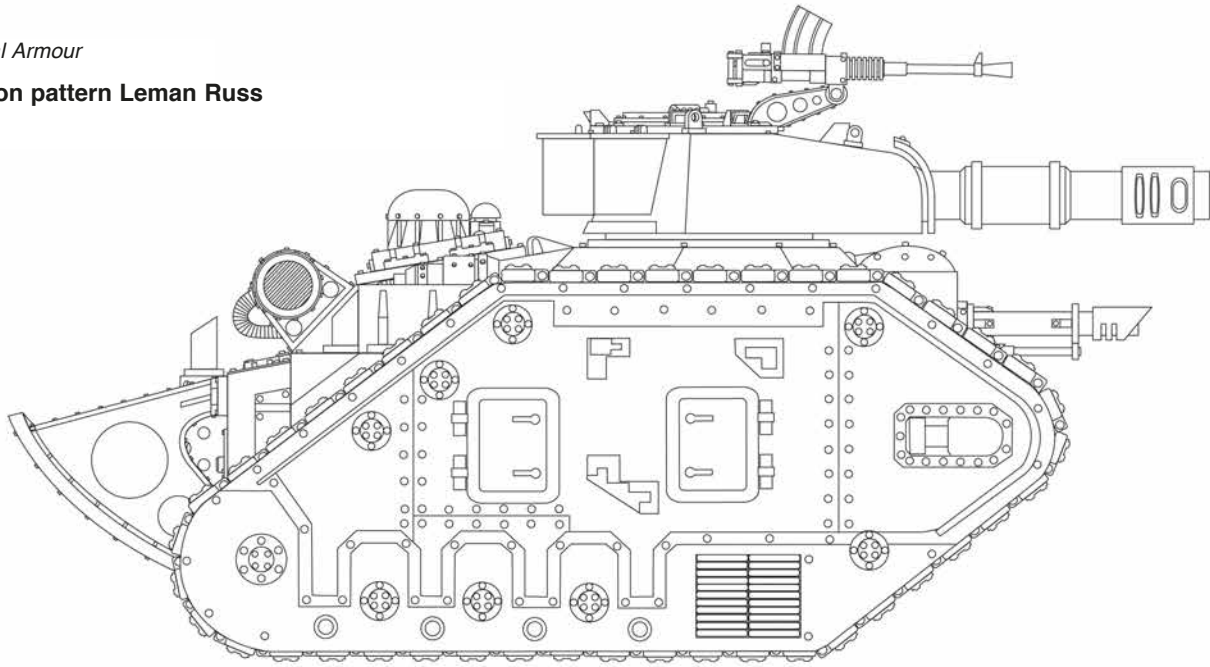

**Mars-Alpha pattern Leman Russ**

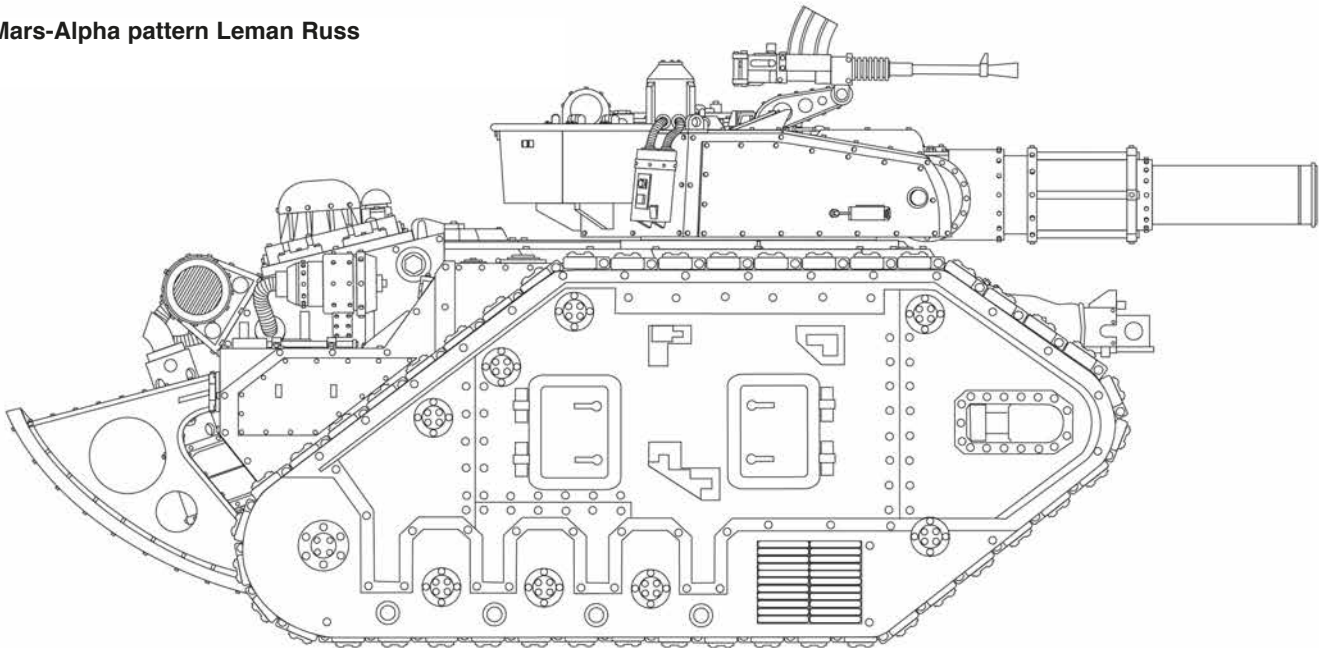

**Mars-Alpha pattern Leman Russ Exterminator**

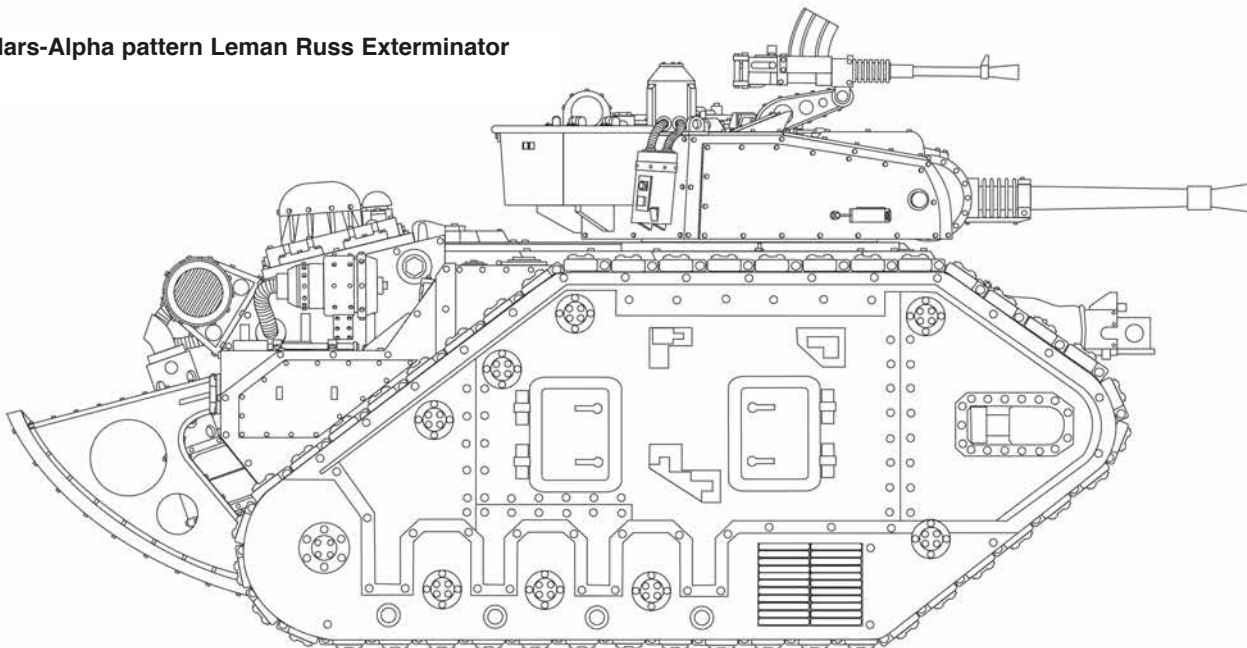

**Mars-Alpha pattern Leman Russ Vanquisher**

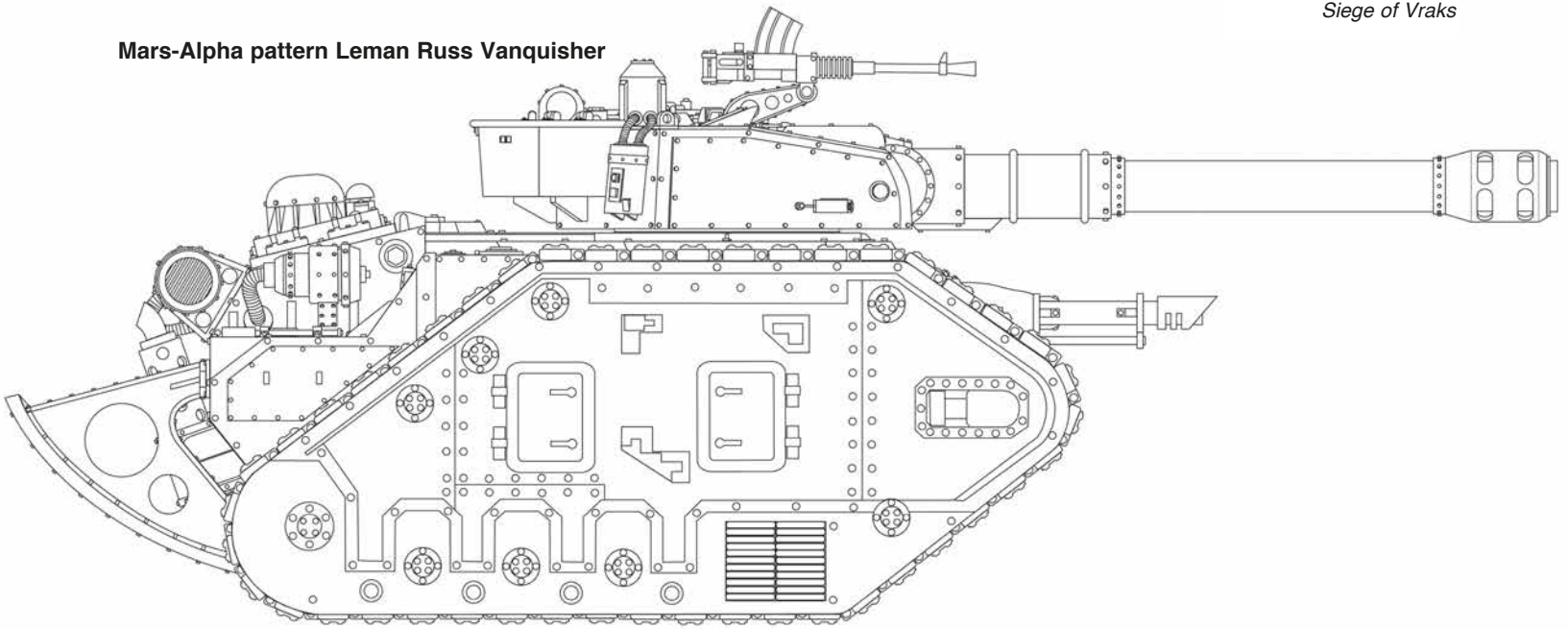

**Mars-Alpha pattern Leman Russ Executioner**

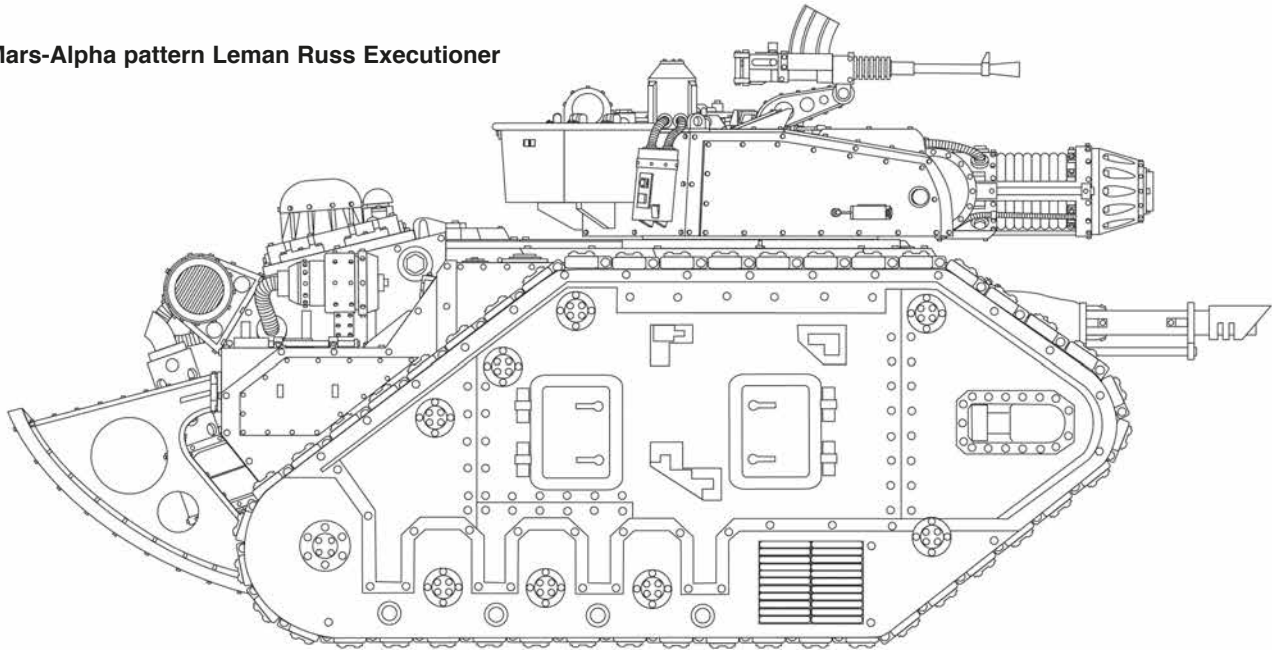

**Mars-Alpha pattern Leman Russ Demolisher**

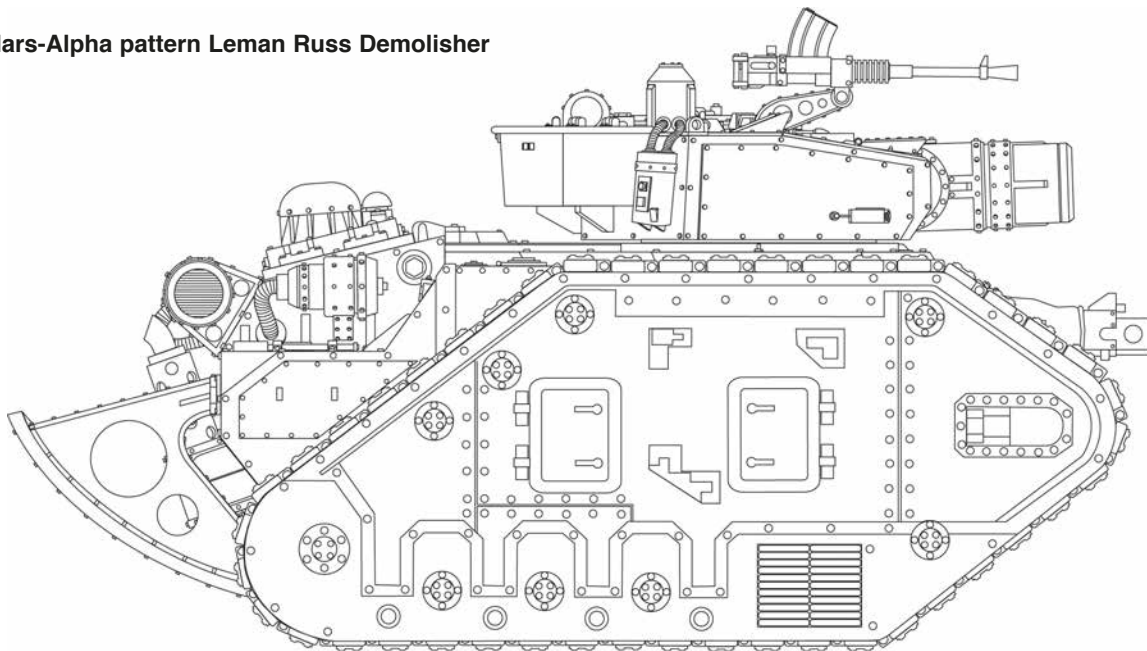



# MACHARIUS



The Macharius is one of a variety of what are referred to as 'second generation' Baneblades. These are built by forge worlds eager to secure large military contracts, but that do not possess the STC data require to build true Baneblades. Only a handful of forge worlds still manufacture Baneblades to the same design as those used during the Great Crusades, and the Adeptus Mechanicus of Mars keep a close guard on which forge worlds are allowed access to the information that they store.

From archive material it is known that, in ancient times, other super-heavy tanks were deployed by the Imperial Army. During the Great Crusades there had been more than a single design of large tanks in the Emperor's service. For years Adeptus Mechanicus munition-adepts have searched for the data for these missing tanks. In the intervening millennia they had fallen out of favour and the knowledge of how they were manufactured, or what they were called, had been lost. Through diligent study, Magos Nalax discovered fragments of a blueprint buried deep in the archives of Lucius forge world. He made it his life's work to re-construct the missing data by cross-referencing with Baneblade components and other vehicles, until he had the plans for the construction of an entire vehicle.

Magos Nalax's work was taken to Mars and placed before the High Fabricator-General for approval. This notoriously lengthy process took another two hundred years, and Nalax himself did not live to see the outcome. After long testing and consultations with many other forge worlds, the plans were finally accepted, and Lucius forgeworld was sanctioned to start production. The tank was named the Macharius, after the great Lord Commander Solar Macharius whose crusades at the beginning of the 41st Millennium had liberated one thousand worlds in the name of

the Emperor. Ironically, in the meantime, Lucius had also lobbied for and been granted the right to build STC Baneblades, and it seemed that Nalax's work would be wasted.

Lucius forge world started production of its Baneblade, but soon found that demand outstripped supply. Lucius struggled to keep up with the Departmento Munitorum's requirements. Then the world of Krieg returned to the Imperium's fold, and suddenly offered new regiments for service with the Imperial Guard. The Departmento Munitorum looked to Lucius to provide much of their equipment.

The sudden increase in demand meant that the rulers of Lucius turned to the Macharius, and in 852.M41 the first tanks rolled off the production lines destined for Krieg. This began the Krieg regiment's association with the Macharius tank, although other regiments have been equipped with them, and indeed Mars has now allowed the production data to be used by other forge worlds.

The 174 tonne Macharius lacks the Baneblade's massive size and many of its weapons, but still fulfils the same battlefield role. It is still a potent war machine, even if the Macharius cannot match the Baneblade's massive firepower, its heavy armour bracing, advanced logis engines and engine performance. Despite this the Macharius is still a heavy tank, with very thick frontal armour, and its twin battle cannons provide devastating firepower. There are rumours that Magos Nalax also developed plans for alternative armaments.

The tank has eight crew, consisting of the commander, gunner and two loaders in the turret, with the driver, comms-operator (who also doubles as the heavy stubber gunner) and two sponson gunners in the hull.

Lucius pattern Macharius heavy tank

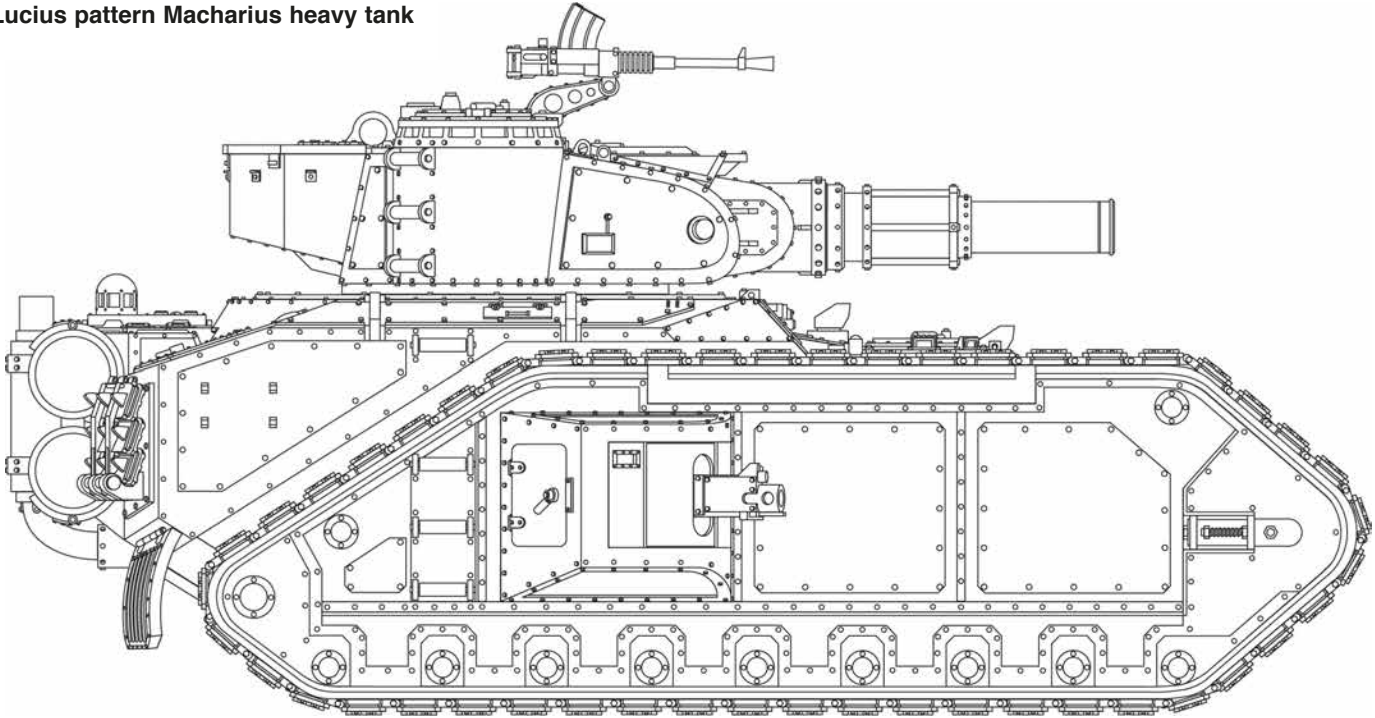

DVL A 6724930

**ADEPTUS MECHANICUS DEPARTMENTO MANUFACTURUM**  
**TECHNICAL SPECIFICATIONS**

---

<p>Vehicle Designation 8769-128-8734-MA12</p> <p>Vehicle Name <u>MACHARIUS</u></p> <p>Forge World of Origin <u>LUCIUS</u></p> <p>Known Patterns <u>I-III</u></p> <p>Crew <u>COMMANDER, DRIVER, GUNNER, 2xLOADERS, 2xSPONSON GUNNERS, COMMS-OPERATOR</u></p> <p>Powerplant <u>LC400 V18 P2 MULTI-FUEL</u></p> <p>Weight <u>175 TONNES</u></p> <p>Length <u>10.9 M</u></p> <p>Width <u>7 M</u></p> <p>Height <u>4.8 M</u></p> <p>Ground Clearance <u>.45 M</u></p> <p>Max Speed = On Road <u>26 KPH</u></p> <p>Max Speed = Off Road <u>18 KPH</u></p>	<p>Main Armament <u>2 X BATTLECANNONS</u></p> <p style="text-align: center;"><u>2 X HEAVY STUBBERS</u></p> <p>Secondary Armament <u>2 X HEAVY BOLTERS</u></p> <p>Traverse <u>360°</u></p> <p>Elevation <u>-2° TO +28°</u></p> <p>Main Ammunition <u>40 ROUNDS</u></p> <p>Secondary Ammunition <u>1000 ROUNDS AND 600 ROUNDS</u></p> <p>Armour</p> <p style="padding-left: 20px;">Turret <u>220 MM</u></p> <p style="padding-left: 20px;">Superstructure <u>200 MM</u></p> <p style="padding-left: 20px;">Hull <u>190 MM</u></p> <p style="padding-left: 20px;">Gun Mantlet <u>150 MM</u></p>
---	--

Date 1544019.M39

signature *Jack K...*

Magos Fabricator

Dominus Ex Machina

Front view

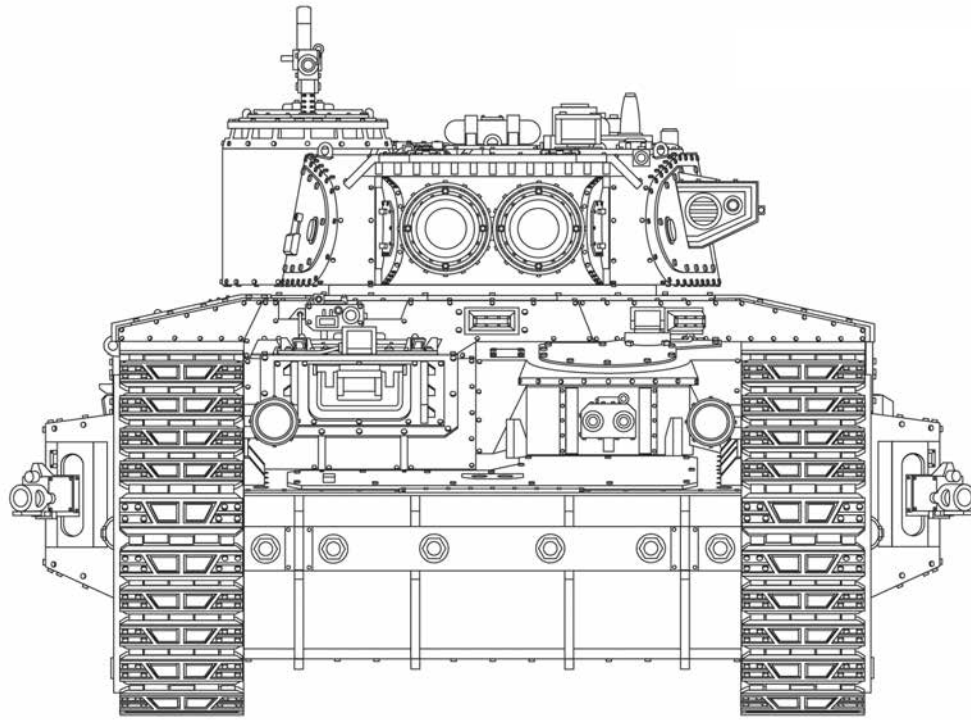

Plan view

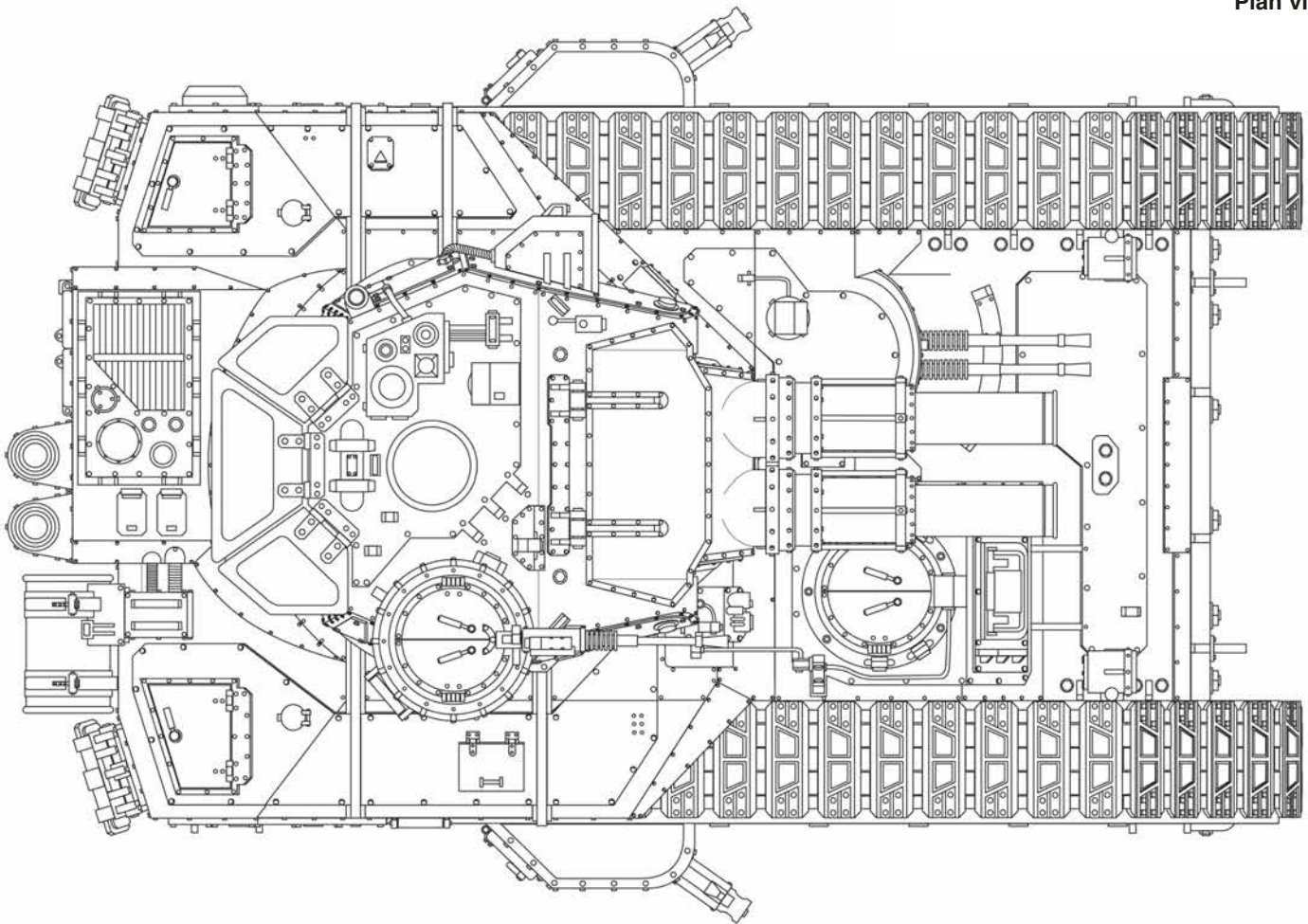



**Top:** A Macharius heavy tank on its way to meet the enemy counter-attack in sector 58-43.

**Above:** The Macharius' formidable main armament is equally potent against enemy armour and infantry.

**Opposite Top:** Tanks of the 7th Tank regiment stand ready to engage advancing enemy tanks.



# THE DARK ANGELS

*"No respite, no forgiveness, no mercy. For we are the Emperor's wrath."*

Interrogator-Chaplain Asmodai from the Third Litany of Malediction.



The Dark Angels are the honoured First Chapter of the First Founding, the original Space Marines, founded before the Imperium of Man had even been created. The Dark Angels Legion fought beside the Emperor during the Great Crusades, and can claim to have liberated or captured hundreds, if not thousands of worlds for the Imperium.

Created using the geneseed of the Primarch Lion El'Jonson, the Dark Angels Legion took Caliban as its home, close to the Eye of Terror. During the dark days of the Great Heresy, when it seemed that the hard won Imperium of Man must fall to the daemon-worshipping traitor Horus, the Dark Angels came within an inch of betraying their Emperor and joining Horus' corrupt rebels. Disaster was narrowly averted, but only at a great cost, and in the aftermath Caliban was destroyed. All that remains today is the Rock, an asteroid splinter of the Chapter's former homeworld, now converted into the Dark Angels' fortress-monastery.

Today the Chapter wreathes itself in secrecy and darkness. They guard ancient secrets that only the Inner Circle of the Dark Angels is privileged to know. From their base they launch relentless campaigns against the enemies of Mankind, striking suddenly, without warning, and with terrible, pitiless fury. But many on Terra believe the Chapter's loyalty is questionable, and that they continually act without regard for the wishes of the rulers of the Imperium. They say that the Chapter is beyond the control of the High Lords of Terra, and worst yet, beyond the restraints of the Emperor's Inquisition. Suspicion of the Chapter is rife, for without the correct controls who knows where the Chapter's true loyalty lies, or what heresy might be breeding within the dark corridors of the Rock?

The Supreme Grand Master of the Dark Angels cares not for such rumours. His Chapter's deeds speak louder than words. For ten thousand years the Dark Angels have fought for their Emperor, driven by a fervour for absolution from their past and a need to remove the stain of disloyalty.

On Vraks, the Dark Angels responded rapidly to the Segmentum High Command's request for assistance. Azrael, the current Supreme Grand Master of the Chapter, responded with a massive show of strength, committing almost half the Chapter's strength to Vraks. Why such a large deployment? Nobody except the Inner Circle knows – but it cannot be ignored that the appearance of Traitor Space Marines on Vraks must have acted as a draw to the Dark Angels. Perhaps this was a chance to settle an old score from ten thousand years ago? To exact revenge from those who joined Horus' rebellion and almost brought about the ruin of the Dark Angels and the Imperium?

The Chapter launched an attack against Vraks star port with the aim of destroying the planet's ability to land reinforcements. The Chapter's battle-brothers fought a furious battle against the renegade militia, and finally encountered the enemy they were seeking – the Alpha Legion warband of Arkos the Faithless. Azrael hoped to capture Arkos or his followers so that his Chaplains could interrogate them for new intelligence about the Fallen. Although the star port was captured and then destroyed, Azrael failed to outwit the Alpha Legion, and was himself almost killed whilst fighting Arkos in hand-to-hand combat. Only the intervention of the Deathwing, led by Interrogator-Chaplain Belphegor saved the Supreme Grand Master's life, although Arkos, no doubt aided by his own gods, also escaped.

# DARK ANGELS STRIKE FORCE

## Vraks Devastation Force

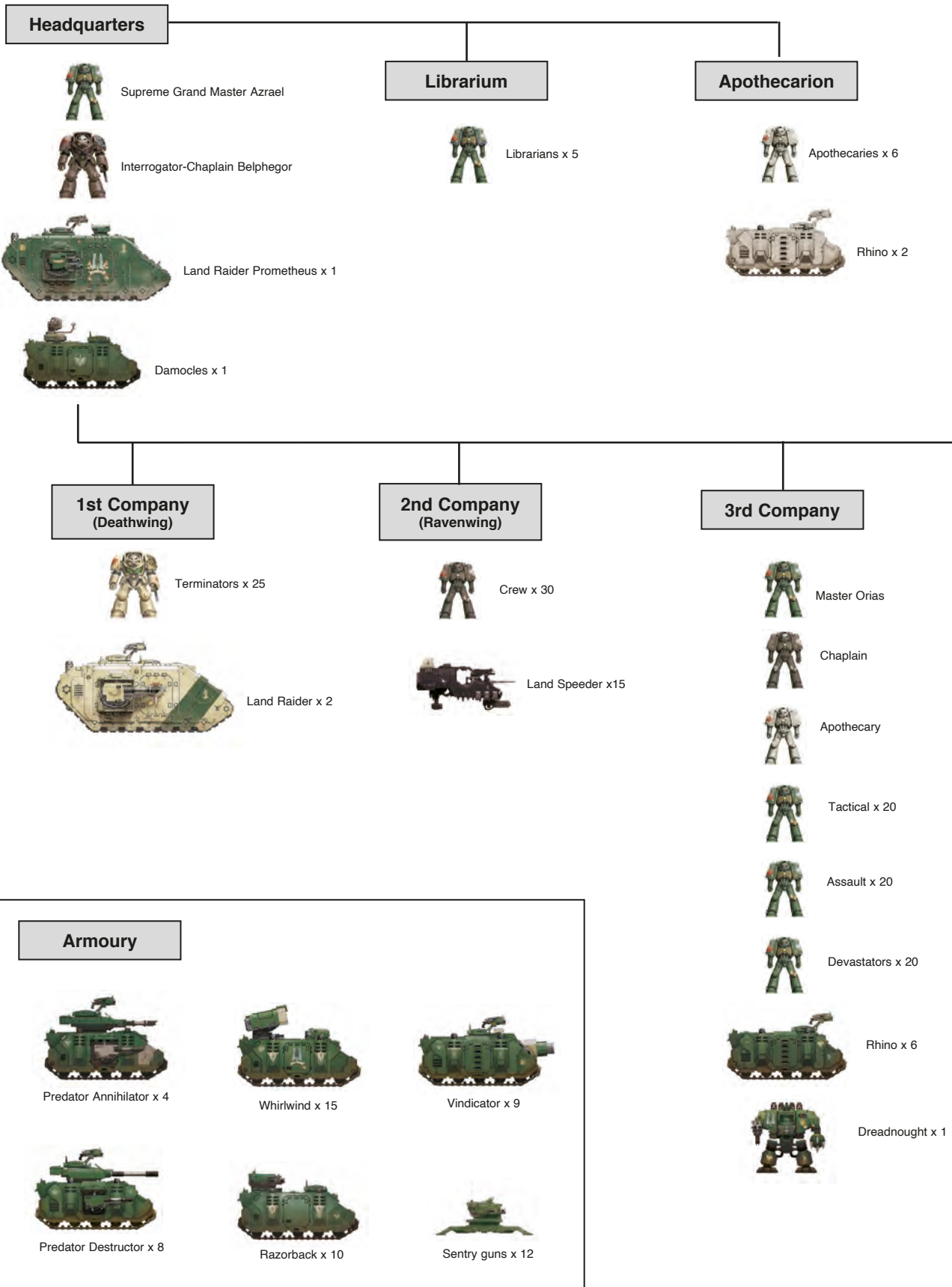

**Fleet**



Battle Barge - *Angel of Retribution*



Strike Cruiser - *Sword of Caliban*



Nova class x 2



Strike Cruiser - *Salvation*



Hunter class x 2



Thunderhawk Gunship x 15

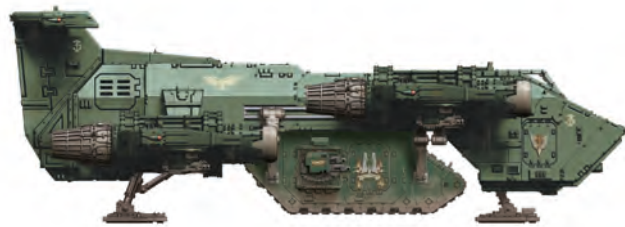

Thunderhawk Transporter x 22



Drop Pods x 42

**5th Company**



Master Helbron



Chaplain



Apothecary



Standard Bearer



Tactical x 60



Assault x 20



Devastator x 20



Rhino x 10



Dreadnought x 4

**6th Company**



Chaplain



Apothecary



Tactical x 70



Rhino x 7

**8th Company**



Assault x 50



Rhino x 5

**9th Company**



Devastator x 40



Rhino x 4

**Armoury**



Techmarine x 17



Servitor x 76



Land Raider x 8



Land Raider Crusader x 2

## DARK ANGELS DEATHWING TERMINATOR SQUAD

Squad Arbalan, 1st Company



**1. Veteran Sergeant Arbalan**  
Squad Commander. 92 Missions.

### SQUAD ARBALAN

One of five Deathwing Terminator squads which took part in the final battle to annihilate the defenders of Vraks star port. At the height of the battle, Squad Arbalan was engaged in ferocious house-to-house fighting against Alpha Legion traitor marines. Arbalan's squad and their Land Raider transport conducted a counter-attack to rescue fellow Dark Angels trapped by an Alpha Legion ambush and surrounded. They broke through and secured an escape route, for the loss of a single battle brother – killed by a direct hit from a meltagun as the squad withdrew.

### TERMINATOR WEAPONS

#### 1-4. Storm Bolter. (Umbra pattern)

Storm bolters are a development of the standard boltgun, designed for close quarters combat. They have a higher rate of fire than the standard boltgun, but correspondingly have a drop-off in accuracy due to the weapon's ferocious recoil whilst rapid firing.

#### 5. Heavy Flamer. (Ultima pattern)

The heavy flamer unit is a standard support weapon for Terminator squads, used for tunnel fighting and room clearance. It is a savage weapon, firing a stream of super-heated promethium, generating temperatures in excess of 900°C, incinerating anything hit. Such is the weapon's fearsome reputation that many foes will flee rather than face the prospect of a terrible death.

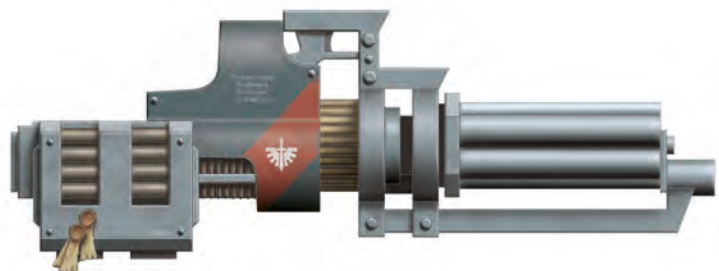
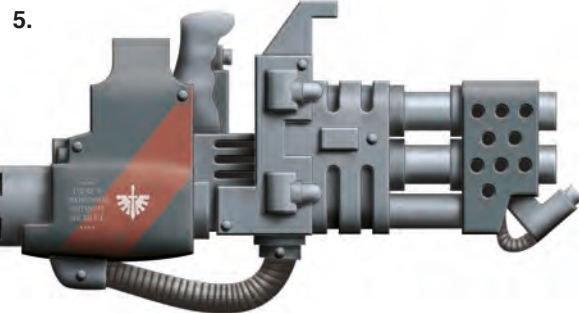

#### Alternative heavy weapon – assault cannon. (Ultima pattern)

Instead of the heavy flamer unit, many Deathwing squads are equipped with an assault cannon, a six-barrelled, self-loading autocannon with a very high rate of fire.



**2. Veteran Brother Nestor**  
52 Missions.



**3. Veteran Brother Aviel**  
Squad 2-i-c. 90 Missions.



**4. Veteran Brother Ares**  
22 Missions.  
KIA on Vraks.



**5. Veteran Brother Zariah**  
39 Missions.

## DARK ANGELS TACTICAL COMBAT-SQUAD BOREAS 2nd Tactical Squad, 5th Company



**1. Veteran Sergeant Boreas**  
48 Missions.

### SQUAD BOREAS

As part of 5th Company's deployment on Vraks, Squad Boreas fought for ten consecutive days at Vraks star port. For flexibility on the battlefield, the ten man squad was split into two five-man combat squads for the duration of the battle. The first half was led by Veteran Sergeant Boreas, whilst the second half was led by Veteran battle brother Gideon.

### TACTICAL SQUAD WEAPONS

**1. Power sword and Plasma pistol (MkII Mars pattern).**

As a squad leader, a veteran battle brother may choose to carry a sword. This master-crafted weapon contains a small powerfield generator in the pommel. When activated, it wreaths the blade in a crackling energy field that disrupts anything hit at a molecular level, greatly assisting armour penetration.

The plasma pistol uses the same ancient technology as the plasma gun but, whilst devastating at close quarters, also suffers all the reliability drawbacks of its larger cousins.

**2. Boltgun with 'Dark-Eye' nightscope (MkII Ultra pattern).**

This boltgun includes the 'Dark-Eye' nightscope, a modification sometimes favoured by Space Marines that have earned the Marksman's Honour. It provides enhanced low-light sighting via the weapon's link to the powered armour's autosenses. Increased magnification and powerful infra-targeting make this scope a useful addition to a squad fighting at longer ranges.

**3-4. Boltgun (MkIV Ultra pattern).**

See overleaf.

**5. Plasma gun (MkV Mars pattern).**

The plasma gun fires highly energised hydrogen plasma, accelerating the 'plasma bolt' via a linear magnetic accelerator. Upon impact the plasma explodes with the destructive heat of a small sun. Whilst effective, plasma weapons are very unreliable. The colossal energies generated by the weapon must be contained within a magnetic field. Failure of this field can result in the weapon overheating in a catastrophic meltdown.

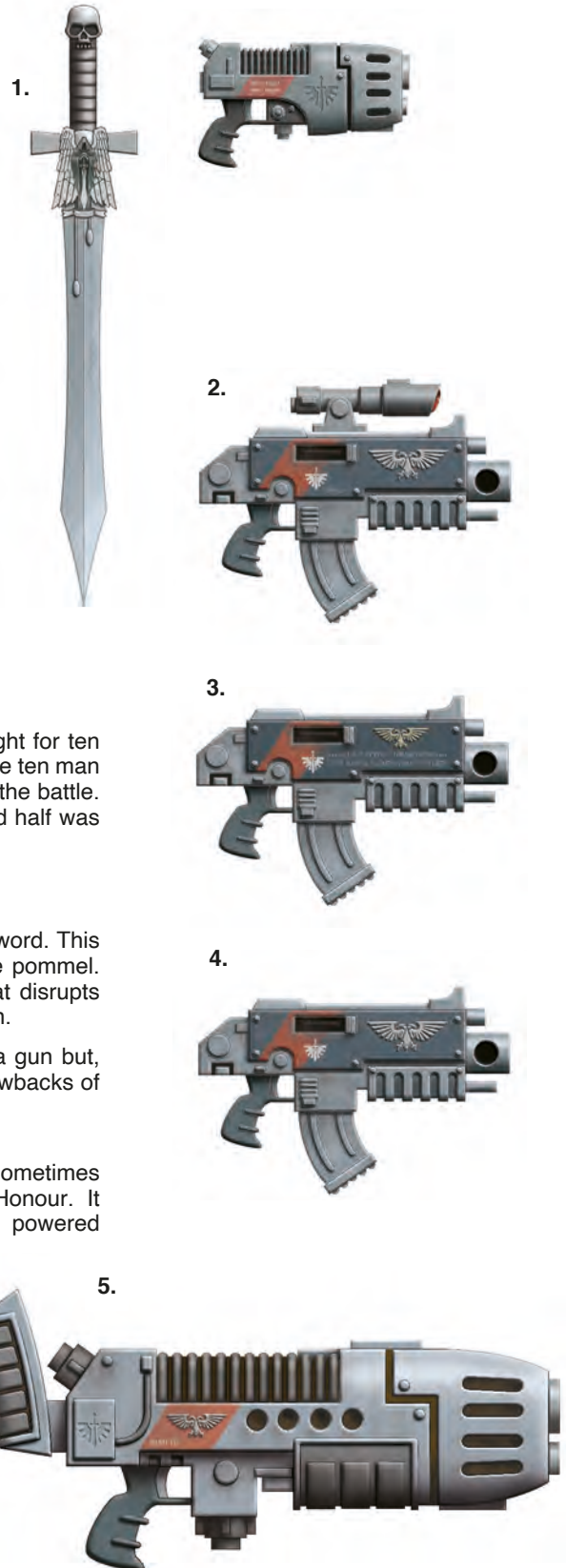



**2. Brother Aryen**  
32 Missions.



**3. Brother Xaron**  
19 Missions.  
KIA on Vraks.



**4. Brother Rakiel.**  
14 Missions.



**5. Brother Adama**  
20 Missions.  
WIA on Vraks



**2. Brother Maor**  
19 Missions.  
WIA on Vraks



**3. Brother Aharon**  
27 Missions.  
KIA on Vraks



**4. Brother Noam**  
7 Missions.



**5. Brother Zachariah**  
21 Missions.

## DARK ANGELS TACTICAL COMBAT SQUAD GIDEON 2nd Tactical Squad, 5th Company



**1. Veteran Brother Gideon**  
34 Missions.  
WIA on Vraks

5.



### TACTICAL SQUAD WEAPONS

**1-4 Boltgun** (MkIV Ultra pattern).

Boltguns are the Codex issue armament of all Space Marine Chapters. They fire self-propelled bolts that detonate after penetrating a target, literally blowing it apart from within. They are superbly made, constructed by skilled artisans of the Chapter's armoury, and many weapons are ancient artefacts of the Chapter.

**5. Lascannon** (MkVII Mars pattern).

Each Tactical squad is equipped with a single heavy weapon, allowing greater battlefield flexibility, as the squad can be used in a support fire role, with the bolt gun equipped battle brothers protecting the heavy weapon.

This squad has been issued a lascannon for use in an anti-armour role. The lascannon fires a powerful blast of laser energy capable of cutting through the thickest armour plating. The weapon itself is very encumbering, and only the Space Marine's greatly enhanced strength and power armour allows the weapon to be man-portable. Most lascannons are tripod or vehicle mounted, but this pattern has been specifically developed to meet the requirements of Space Marine Chapters.



Right shoulder pad.  
Squad number and designation marking.



Left shoulder pad.  
Chapter badge.

1-4.



## Other Space Marine Weapons

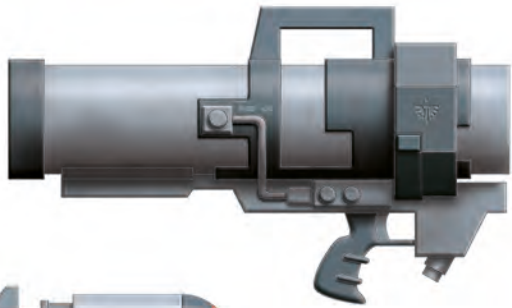

Missile Launcher



### Missile Launcher

The man-portable tactical missile launcher provides a squad with flexible heavy weapons fire. It fires an armour-piercing krak warhead (shown here), capable of eliminating hard targets and enemy vehicles at long range. It can also provide anti-infantry suppressive firepower with fragmentation missiles. This is the Mk III Mars pattern missile launcher. It is a single shot weapon, and must be reloaded after each shot. Squad members will carry extra missiles for the weapon

### Bolt Pistol

Carried as a side arm by many Space Marines, and issued as standard to battle brothers armed with heavy weapons and special weapons. The pistol fires the same rounds as the bolt gun, using the same technology. Capable of single shot or three round bursts, the pistol lacks range and accuracy, but the bolt's stopping power mean it is highly effective at short ranges and during close combat. The weapon's magazine holds ten rounds.



Bolt Pistol

Heavy Bolter

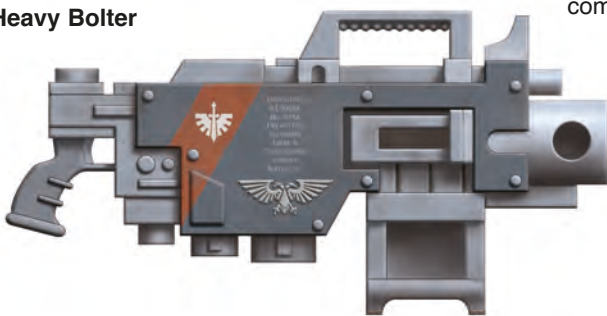

### Heavy Bolter

This heavy weapon is sometimes issued to squads instead of the missile launcher or lascannon for fire support. In the hands of a Space Marine, assisted by his power armour, the heavy bolter become a man-portable weapon. The heavy bolter fires a larger, heavier bolt over longer range than the standard bolt gun and is supplied by a high capacity 40 round magazine, or a disintegrating belt. The weapon can also be fitted with a bipod, so it can be used in a sustained fire role.

## Other squad shoulder pads

As well as Tactical squads, each battle company also fields Assault and Devastator squads. These squads bear their own markings and their squad number on the right shoulder pad – shown here.



Right shoulder pad.  
8th Assault squad.



Right shoulder pad.  
9th Devastator squad.

## Vehicle Markings

*Dark Angels vehicles bear a variety of markings both for identification, dedication and protection. Just as with the Chapter's battle-brothers, each vehicle's 'soul' must be protected from corruption through purity and loyalty to the Emperor.*



### Chapter Iconography.

Symbols are often castings taken from the company shrines of the Fortress-Monastery or, in rare cases, taken from the Emperor's Palace on Terra. This icon's scroll-work carries the vehicle's name.

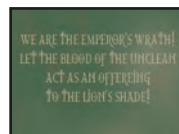

### Litanies.

Prayers and litanies taken from the Chapter's important religious works engraved into the vehicle.



### Parchment and Purity Seals.

Dedicational scrolls and purity seals protect the vehicle's machine-spirit from possession or malfunction.



### Company Number.

Each vehicle either belongs to a company or is attached to a company from the Chapter armoury for the campaign.



# FORCES OF CHAOS

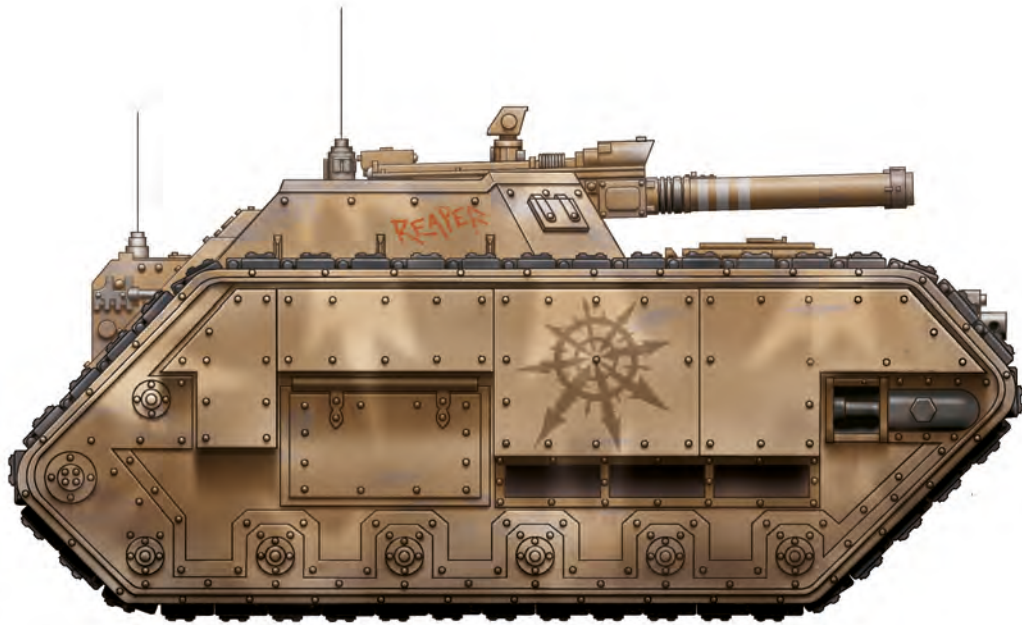

A Salamander scout vehicle encountered by the Dark Angels during the Battle for Vraks star port.  
Note the crew have called their vehicle 'Reaper'.

# OGRYN BERSERKER



## 1. Equipment

This Ogryn has been heavily surgically altered using proscribed neurological and bio-chemical processes. This crude adaptation starts by lobotomising the Ogryn, turning it into an imbecilic, docile creature, unable to even feed itself and becoming utterly enslaved to its masters – until the chemical injectors are activated. The injectors deliver a cocktail of potent, highly dangerous drugs, including the banned combat drug called ‘Slaughter’ into the Ogryn’s bloodstream and muscles. ‘Slaughter’, once favoured by such notorious Space Marine Chapters as the Flesh Tearers and World Eaters, stimulates the subject’s adrenaline glands and the neural pathways to the areas of the brain that govern aggression. With these driven into overdrive, the user becomes a raging psychopath, driven by a bloodlust that cannot be sated. Other drugs are also injected, including various phencyclidines that give the taker massively increased strength and an almost super-human ability to block pain – with side effects inducing hallucinations and a desire for self-mutilation. Strong beta-adrenoreceptor blocking drugs augment this, allowing the Ogryn to fight on with terrible wounds that would usually kill it out right.

The downside of this drug-fuel rampage is that the body’s system is unlikely to be able to cope with the drugs for long, and vital internal organs will quickly start to fail. Ogryn Berserkers were used as expendable troops on Vraks, and were not supposed to survive their first encounter with the enemy. They were a one-use weapon, hurled into the enemy in furious counter-attacks with the single aim of inflicting as much damage as possible before collapsing, or being killed in their turn.

Although the Ogryn bears the heretical symbols of a Chaos worshipper, these must have been added by its masters. Even before surgery Ogryn’s brains do not easily comprehend concepts such as ideology or religious worship, although they do have a strong basic instinct for loyalty to their leaders (making them useful as bodyguards). An Ogryn only needs to know who its enemies are, not why it must fight. The removal of this creature’s higher brain functions (such as they are), means it fights only on instinct.

## 2. Armour

The Ogryn’s armour has been constructed from scrap metal and attached to the Ogryn’s harness, clothing, or to the Ogryn itself, via chains and loops. This crude armour provides rudimentary protection against enemy fire, is more useful against enemy hand-to-hand attacks (should any enemy be unfortunate enough to be caught in hand-to-hand combat with the creature) and adds extra bulk and weight the Ogryn, allowing it to smash opponents out of the way as it charges. Additional blades have been welded to the armour, making the frenzied Ogryn difficult to approach without the risk of injury. Underneath the Ogryn’s armour, it wears the tattered remains of its work overall.

## 3. Weapons

This Ogryn carries two close combat weapons. Its main weapon is a rock-cutting saw, which has been surgically attached to its arm. It includes its own motor, and diamantine-tipped cutting blade. The tool would usually be used during demolition work for cutting through plasteel and ferrocrete. Used against flesh it has spectacularly gory effects.

Each Ogryn is armed with its own tools, scrounged from the labour corps supplies, and often modified to make them into more efficient weapons. As well as powered weapons such as rock drills, cutters and angle-grinders, Ogryns also carried sledge hammers, pick axes, shovels, spiked clubs, crowbars or even crude cleavers made from sharpened steel off-cuts. Being expendable troops, little effort was made to arm them.

The Ogryn’s secondary weapon is a crudely forged punch-blade, strapped to its left arm via chains. Like the creature’s armour, these have been cut from scrap metal.

*This is a renegade Ogryn Berserker, encountered during one of 150th regiment’s attacks against the outer defence lines. The Berserker was killed in the action, but not before killing fifteen Krieg guardsmen.*







# APPENDICES

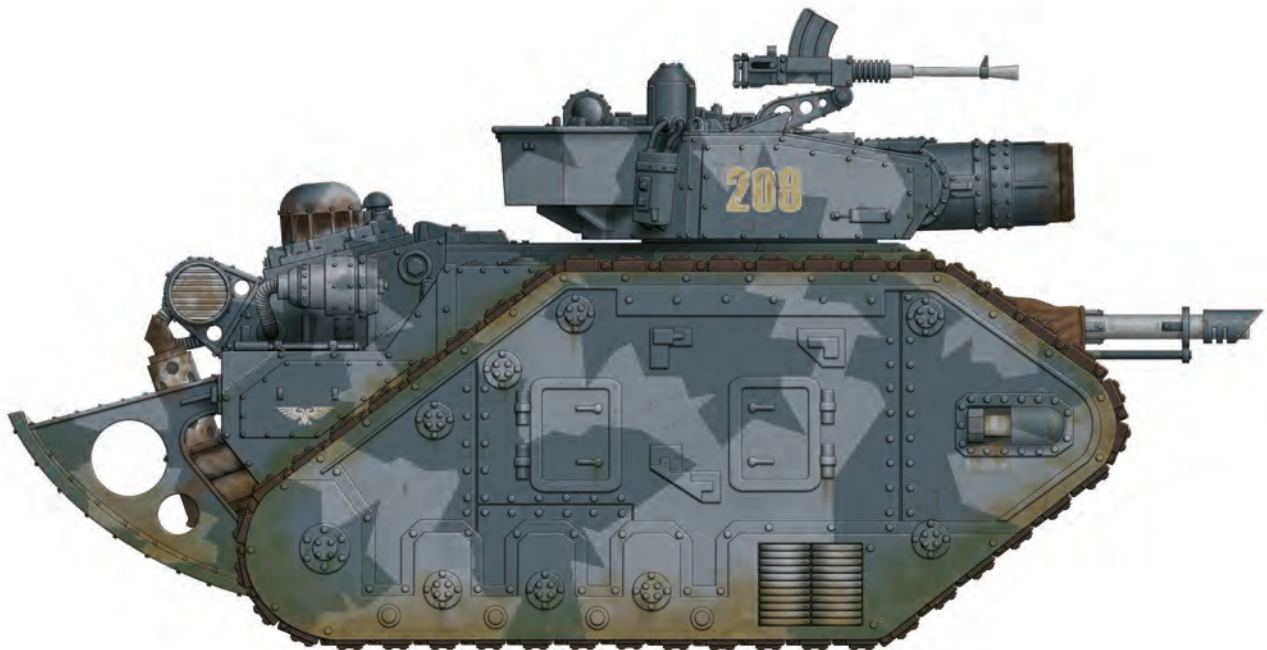

Leman Russ Demolisher of the 61st tank regiment,  
second vehicle of the headquarters squadron, 9th company.

# APPENDIX

## KRIEG VEHICLE COLOUR SCHEMES & MARKINGS

Krieg regiments utilise a variety of different colour schemes and camouflage patterns on their vehicles. The base colour usually relates to the regiment's uniform colour, be it grey, green, brown or black. Over this a camouflage pattern is added. These tends to be confusion patterns, designed to disrupt the shape of the vehicle and prevent easy targeting and recognition, rather than concealment patterns which attempt to hide the vehicle. Given Krieg regiment's style of warfare, there is little need for concealment, as no-man's land offers very few places to hide a vehicle, and any potential hiding places have usually been destroyed by artillery bombard long before tanks are committed to action.

Identification numbers, letters and stripes are widely used, although each regiment, and even each company, seems to use its own method of identification and there is little standardization.

The commonest disruption camouflage scheme is the half-feathered pattern, which is used by many regiments. Some companies also use variations on this pattern, either without the feathering – making a block pattern, or with complete feathering – forming stripes.

Crew will also add their own markings. Dedicational eagles, vehicle names, slogans and kill markings are all used.

These colour schemes are also affected by weathering. Vraks' atmosphere, prolonged exposure to the elements, dust, dirt and damage caused by day-to-day wear and tear or enemy fire all cause a vehicle's appearance to change over time.

### Colour Schemes.

1. Common Krieg pattern. Two-tone grey, half feathered, disruption pattern.
2. Two tone, unfeathered, block disruption pattern.
3. Two tone feathered stripes, disruption pattern and dedicational eagle.
4. Rarely used, green-brown concealment pattern.
5. Plain green with identification numbering
6. Brown two-tone, this has been added in the field by the vehicles crew and conforms to no known camouflage type.

1.



2.



3.

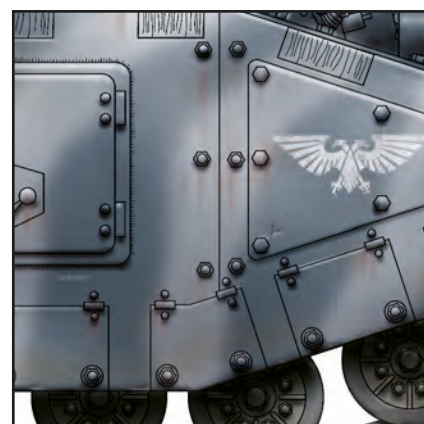

4.



5.



6.





Above: Two Macharius heavy tanks of 61st Tank regiment move across no-man's land during the advance to the inner defence lines. Macharius' and Baneblades fulfil the same battlefield role, with the Macharius filling in for a lack of available Baneblades. 61st Tank regiment's order of battle for the start of the Vraks campaign shows it had only 8 Baneblades and 3 Stormblades, with 26 Macharius' filling out the rest of the heavy tank companies.

